

# ANSWERS

## Chapter 8

- 8.1** 1.8
- 8.2** (a) From the given graph for a stress of  $150 \times 10^6 \text{ N m}^{-2}$  the strain is 0.002  
(b) Approximate yield strength of the material is  $3 \times 10^8 \text{ N m}^{-2}$
- 8.3** (a) Material A  
(b) Strength of a material is determined by the amount of stress required to cause fracture: material A is stronger than material B.
- 8.4** (a) False (b) True
- 8.5**  $1.5 \times 10^{-4} \text{ m}$  (steel);  $1.3 \times 10^{-4} \text{ m}$  (brass)
- 8.6** Deflection =  $4 \times 10^{-6} \text{ m}$
- 8.7**  $2.8 \times 10^{-6}$
- 8.8** 0.127
- 8.9**  $7.07 \times 10^4 \text{ N}$
- 8.10**  $D_{\text{copper}}/D_{\text{iron}} = 1.25$
- 8.11**  $1.539 \times 10^{-4} \text{ m}$
- 8.12**  $2.026 \times 10^9 \text{ Pa}$
- 8.13**  $1.034 \times 10^3 \text{ kg/m}^3$
- 8.14** 0.0027
- 8.15**  $0.058 \text{ cm}^3$
- 8.16**  $2.2 \times 10^6 \text{ N/m}^2$

## Chapter 9

- 9.3** (a) decreases (b)  $\eta$  of gases increases,  $\eta$  of liquid decreases with temperature (c) shear strain, rate of shear strain (d) conservation of mass, Bernoulli's equation (e) greater.
- 9.5**  $6.2 \times 10^6$  Pa
- 9.6** 10.5 m
- 19.7** Pressure at that depth in the sea is about  $3 \times 10^7$  Pa. The structure is suitable since it can withstand far greater pressure or stress.
- 9.8**  $6.92 \times 10^5$  Pa
- 9.9** 0.800
- 9.10** Mercury will rise in the arm containing spirit; the difference in levels of mercury will be 0.221 cm.
- 9.11** No, Bernoulli's principle applies to streamline flow only.
- 9.12** No, unless the atmospheric pressures at the two points where Bernoulli's equation is applied are significantly different.
- 9.13**  $9.8 \times 10^2$  Pa (The Reynolds number is about 0.3 so the flow is laminar).
- 9.14**  $1.5 \times 10^3$  N
- 9.15** Fig (a) is incorrect [Reason: at a constriction (i.e. where the area of cross-section of the tube is smaller), flow speed is larger due to mass conservation. Consequently pressure there is smaller according to Bernoulli's equation. We assume the fluid to be incompressible].
- 9.16**  $0.64 \text{ m s}^{-1}$
- 9.17**  $2.5 \times 10^{-2} \text{ N m}^{-1}$
- 9.18**  $4.5 \times 10^{-2} \text{ N}$  for (b) and (c), the same as in (a).
- 9.19** Excess pressure = 310 Pa, total pressure =  $1.0131 \times 10^5$  Pa. However, since data are correct to three significant figures, we should write total pressure inside the drop as  $1.01 \times 10^5$  Pa.
- 9.20** Excess pressure inside the soap bubble = 20.0 Pa; excess pressure inside the air bubble in soap solution = 10.0 Pa. Outside pressure for air bubble =  $1.01 \times 10^5 + 0.4 \times 10^3 \times 9.8 \times 1.2 = 1.06 \times 10^5$  Pa. The excess pressure is so small that up to three significant figures, total pressure inside the air bubble is  $1.06 \times 10^5$  Pa.

## Chapter 10

- 10.1** Neon:  $-248.58 \text{ }^\circ\text{C} = -415.44 \text{ }^\circ\text{F}$ ;  
 $\text{CO}_2$ :  $-56.60 \text{ }^\circ\text{C} = -69.88 \text{ }^\circ\text{F}$

$$\text{(use } t_{\text{F}} = \frac{9}{5}t_{\text{C}} + 32)$$

- 10.2**  $T_A = (4/7) T_B$
- 10.3** 384.8 K
- 10.4** (a) Triple-point has a *unique* temperature; fusion point and boiling point temperatures depend on pressure; (b) The other fixed point is the absolute zero itself; (c) Triple-point is 0.01°C, not 0 °C; (d) 491.69.
- 10.5** (a)  $T_A = 392.69$  K,  $T_B = 391.98$  K; (b) The discrepancy arises because the gases are not perfectly ideal. To reduce the discrepancy, readings should be taken for lower and lower pressures and the plot between temperature measured versus absolute pressure of the gas at triple point should be extrapolated to obtain temperature in the limit pressure tends to zero, when the gases approach ideal gas behaviour.
- 10.6** Actual length of the rod at 45.0 °C = (63.0 + 0.0136) cm = 63.0136 cm. (However, we should say that change in length up to three significant figures is 0.0136 cm, but the total length is 63.0 cm, up to three significant places. Length of the same rod at 27.0 °C = 63.0 cm.
- 10.7** When the shaft is cooled to temperature – 69°C the wheel can slip on the shaft.
- 10.8** The diameter increases by an amount =  $1.44 \times 10^{-2}$  cm.
- 10.9**  $3.8 \times 10^2$  N
- 10.10** Since the ends of the combined rod are not clamped, each rod expands freely.  
 $\Delta l_{\text{brass}} = 0.21$  cm,  $\Delta l_{\text{steel}} = 0.126$  cm = 0.13 cm  
 Total change in length = 0.34 cm. No ‘thermal stress’ is developed at the junction since the rods freely expand.
- 10.11**  $0.0147 = 1.5 \times 10^{-2}$
- 10.12** 103 °C
- 10.13** 1.5 kg
- 10.14**  $0.43 \text{ J g}^{-1} \text{ K}^{-1}$  ; smaller
- 10.15** The gases are diatomic, and have other degrees of freedom (i.e. have other modes of motion) possible besides the translational degrees of freedom. To raise the temperature of the gas by a certain amount, heat is to be supplied to increase the average energy of all the modes. Consequently, molar specific heat of diatomic gases is more than that of monatomic gases. It can be shown that if only rotational modes of motion are considered, the molar specific heat of diatomic gases is nearly  $(5/2) R$  which agrees with the observations for all the gases listed in the table, except chlorine. The higher value of molar specific heat of chlorine indicates that besides rotational modes, vibrational modes are also present in chlorine at room temperature.
- 10.16** 4.3 g/min
- 10.17** 3.7 kg
- 10.18** 238 °C
- 10.20** 9 min

## Chapter 11

- 11.1** 16 g per min
- 11.2** 934 J
- 11.4** 2.64
- 11.5** 16.9 J
- 11.6** (a) 0.5 atm (b) zero (c) zero (assuming the gas to be ideal) (d) No, since the process (called free expansion) is rapid and cannot be controlled. The intermediate states are non-equilibrium states and do not satisfy the gas equation. In due course, the gas does return to an equilibrium state.
- 11.7** 25 W
- 11.8** 450 J

## Chapter 12

- 12.1**  $4 \times 10^{-4}$
- 12.3** (a) The dotted plot corresponds to 'ideal' gas behaviour; (b)  $T_1 > T_2$ ; (c)  $0.26 \text{ J K}^{-1}$ ; (d) No,  $6.3 \times 10^{-5} \text{ kg}$  of  $\text{H}_2$  would yield the same value
- 12.4** 0.14 kg
- 12.5**  $5.3 \times 10^{-6} \text{ m}^3$
- 12.6**  $6.10 \times 10^{26}$
- 12.7** (a)  $6.2 \times 10^{-21} \text{ J}$  (b)  $1.24 \times 10^{-19} \text{ J}$  (c)  $2.1 \times 10^{-16} \text{ J}$
- 12.8** Yes, according to Avogadro's law. No,  $v_{\text{rms}}$  is largest for the lightest of the three gases; neon.
- 12.9**  $2.52 \times 10^3 \text{ K}$
- 12.10** Use the formula for mean free path :

$$\bar{l} = \frac{1}{\sqrt{2} \pi n d^2}$$

where  $d$  is the diameter of a molecule. For the given pressure and temperature  $N/V = 5.10 \times 10^{25} \text{ m}^{-3}$  and  $\bar{l} = 1.0 \times 10^{-7} \text{ m}$ .  $v_{\text{rms}} = 5.1 \times 10^2 \text{ m s}^{-1}$ .

collisional frequency =  $\frac{v_{\text{rms}}}{\bar{l}} = 5.1 \times 10^9 \text{ s}^{-1}$ . Time taken for the collision =  $d / v_{\text{rms}} = 4 \times 10^{-13} \text{ s}$ .

Time taken between successive collisions =  $1 / v_{\text{rms}} = 2 \times 10^{-10} \text{ s}$ . Thus the time taken between successive collisions is 500 times the time taken for a collision. Thus a molecule in a gas moves essentially free for most of the time.

### Chapter 13

- 13.1** (b), (c)
- 13.2** (b) and (c): SHM; (a) and (d) represent periodic but not SHM [A polyatomic molecule has a number of natural frequencies; so in general, its vibration is a superposition of SHM's of a number of different frequencies. This superposition is periodic but not SHM].
- 13.3** (b) and (d) are periodic, each with a period of 2 s; (a) and (c) are not periodic. [Note in (c), repetition of merely one position is not enough for motion to be periodic; the entire motion during one period must be repeated successively].
- 13.4** (a) Simple harmonic,  $T = (2\pi/\omega)$ ; (b) periodic,  $T = (2\pi/\omega)$  but not simple harmonic; (c) simple harmonic,  $T = (\pi/\omega)$ ; (d) periodic,  $T = (2\pi/\omega)$  but not simple harmonic; (e) non-periodic; (f) non-periodic (physically not acceptable as the function  $\rightarrow \infty$  as  $t \rightarrow \infty$ ).
- 13.5** (a) 0, +, +; (b) 0, -, -; (c) -, 0, 0; (d) -, -, -; (e) +, +, +; (f) -, -, -.
- 13.6** (c) represents a simple harmonic motion.
- 13.7**  $A = \sqrt{2} \text{ cm}$ ,  $\phi = 7\pi/4$ ;  $B = \sqrt{2} \text{ cm}$ ,  $a = \pi/4$ .
- 13.8** 219 N
- 13.9** Frequency  $3.2 \text{ s}^{-1}$ ; maximum acceleration of the mass  $8.0 \text{ m s}^{-2}$ ; maximum speed of the mass  $0.4 \text{ m s}^{-1}$ .
- 13.10** (a)  $x = 2 \sin 20t$   
 (b)  $x = 2 \cos 20t$   
 (c)  $x = -2 \cos 20t$
- where  $x$  is in cm. These functions differ neither in amplitude nor frequency. They differ in initial phase.
- 13.11** (a)  $x = -3 \sin \pi t$  where  $x$  is in cm.
- (b)  $x = -2 \cos \frac{\pi}{2} t$  where  $x$  is in cm.
- 13.13** (a)  $F/k$  for both (a) and (b).
- (b)  $T = 2\pi\sqrt{\frac{m}{k}}$  for (a) and  $2\pi\sqrt{\frac{m}{2k}}$  for (b)

**13.14** 100 m/min

**13.15** 8.4 s

**13.16**  $T = 2\pi \sqrt{\frac{l}{\sqrt{g^2 + v^4/R^2}}}$ . Hint: Effective acceleration due to gravity will get reduced due to radial acceleration  $v^2/R$  acting in the horizontal plane.

**13.17** In equilibrium, weight of the cork equals the up thrust. When the cork is depressed by an amount  $x$ , the net upward force is  $Ax\rho_1g$ . Thus the force constant  $k = A\rho_1g$ .

Using  $m = Ah\rho$ , and  $T = 2\pi \sqrt{\frac{m}{k}}$  one gets the given expression.

**13.18** When both the ends are open to the atmosphere, and the difference in levels of the liquid in the two arms is  $h$ , the net force on the liquid column is  $Ah\rho g$  where  $A$  is the area of cross-section of the tube and  $\rho$  is the density of the liquid. Since restoring force is proportional to  $h$ , motion is simple harmonic.

#### Chapter 14

**14.1** 0.5 s

**14.2** 8.7 s

**14.3**  $2.06 \times 10^4$  N

**14.4** Assume ideal gas law:  $P = \frac{\rho RT}{M}$ , where  $\rho$  is the density,  $M$  is the molecular mass, and

$T$  is the temperature of the gas. This gives  $v = \sqrt{\frac{\gamma RT}{M}}$ . This shows that  $v$  is:

(a) Independent of pressure.

(b) Increases as  $\sqrt{T}$ .

(c) The molecular mass of water (18) is less than that of  $N_2$  (28) and  $O_2$  (32).

Therefore as humidity increases, the effective molecular mass of air decreases and hence  $v$  increases.

**14.5** The converse is not true. An obvious requirement for an acceptable function for a travelling wave is that it should be finite everywhere and at all times. Only function (c) satisfies this condition, the remaining functions cannot possibly represent a travelling wave.

**14.6** (a)  $3.4 \times 10^{-4}$  m      (b)  $1.49 \times 10^{-3}$  m

- 14.7**  $4.1 \times 10^{-4}$  m
- 14.8** (a) A travelling wave. It travels from right to left with a speed of  $20 \text{ ms}^{-1}$ .  
(b) 3.0 cm, 5.7 Hz  
(c)  $\pi/4$   
(d) 3.5 m
- 14.9** All the graphs are sinusoidal. They have same amplitude and frequency, but different initial phases.
- 14.10** (a)  $6.4 \pi$  rad  
(b)  $0.8 \pi$  rad  
(c)  $\pi$  rad  
(d)  $(\pi/2)$  rad
- 14.11** (a) Stationary wave  
(b)  $l = 3$  m,  $n = 60$  Hz, and  $v = 180 \text{ m s}^{-1}$  for each wave  
(c) 648 N
- 14.12** (a) All the points except the nodes on the string have the same frequency and phase, but not the same amplitude.  
(b) 0.042 m
- 14.13** (a) Stationary wave.  
(b) Unacceptable function for any wave.  
(c) Travelling harmonic wave.  
(d) Superposition of two stationary waves.
- 14.14** (a)  $79 \text{ m s}^{-1}$   
(b) 248 N
- 14.15**  $347 \text{ m s}^{-1}$
- Hint :  $v_n = \frac{(2n-1)v}{4l}$  ;  $n = 1, 2, 3, \dots$  for a pipe with one end closed
- 14.16**  $5.06 \text{ km s}^{-1}$
- 14.17** First harmonic (fundamental); No.
- 14.18** 318 Hz

# BIBLIOGRAPHY

## TEXTBOOKS

For additional reading on the topics covered in this book, you may like to consult one or more of the following books. Some of these books however are more advanced and contain many more topics than this book.

1. **Ordinary Level Physics**, A.F. Abbott, Arnold-Heinemann (1984).
2. **Advanced Level Physics**, M. Nelkon and P. Parker, 6<sup>th</sup> Edition Arnold-Heinemann (1987).
3. **Advanced Physics**, Tom Duncan, John Murray (2000).
4. **Fundamentals of Physics**, David Halliday, Robert Resnick and Jearl Walker, 7<sup>th</sup> Edition John Wily (2004).
5. **University Physics**, H.D. Young, M.W. Zemansky and F.W. Sears, Narosa Pub. House (1982).
6. **Problems in Elementary Physics**, B. Bukhovtza, V. Krivchenkov, G. Myakishev and V. Shalnov, MIR Publishers, (1971).
7. **Lectures on Physics** (3 volumes), R.P. Feynman, Addison – Wesley (1965).
8. **Berkeley Physics Course** (5 volumes) McGraw Hill (1965).
  - a. Vol. 1 – Mechanics: (Kittel, Knight and Ruderman)
  - b. Vol. 2 – Electricity and Magnetism (E.M. Purcell)
  - c. Vol. 3 – Waves and Oscillations (Frank S. Crawford)
  - d. Vol. 4 – Quantum Physics (Wichmann)
  - e. Vol. 5 – Statistical Physics (F. Reif)
9. **Fundamental University Physics**, M. Alonso and E. J. Finn, Addison – Wesley (1967).
10. **College Physics**, R.L. Weber, K.V. Manning, M.W. White and G.A. Weygand, Tata McGraw Hill (1977).
11. **Physics: Foundations and Frontiers**, G. Gamow and J.M. Cleveland, Tata McGraw Hill (1978).
12. **Physics for the Inquiring Mind**, E.M. Rogers, Princeton University Press (1960)
13. **PSSC Physics Course**, DC Heath and Co. (1965) Indian Edition, NCERT (1967)
14. **Physics Advanced Level**, Jim Breithampt, Stanley Thornes Publishers (2000).
15. **Physics**, Patrick Fullick, Heinemann (2000).



16. **Conceptual Physics**, Paul G. Hewitt, Addison-Wesley (1998).
17. **College Physics**, Raymond A. Serway and Jerry S. Faughn, Harcourt Brace and Co. (1999).
18. **University Physics**, Harris Benson, John Wiley (1996).
19. **University Physics**, William P. Crummet and Arthur B. Western, Wm.C. Brown (1994).
20. **General Physics**, Morton M. Sternheim and Joseph W. Kane, John Wiley (1988).
21. **Physics**, Hans C. Ohanian, W.W. Norton (1989).
22. **Advanced Physics**, Keith Gibbs, Cambridge University Press(1996).
23. **Understanding Basic Mechanics**, F. Reif, John Wiley (1995).
24. **College Physics**, Jerry D. Wilson and Anthony J. Buffa, Prentice-Hall (1997).
25. **Senior Physics, Part – I**, I.K. Kikoin and A.K. Kikoin, Mir Publishers (1987).
26. **Senior Physics, Part – II**, B. Bekhovtsev, Mir Publishers (1988).
27. **Understanding Physics**, K. Cummings, Patrick J. Cooney, Priscilla W. Laws and Edward F. Redish, John Wiley (2005)
28. **Essentials of Physics**, John D. Cutnell and Kenneth W. Johnson, John Wiley (2005)

### GENERAL BOOKS

For instructive and entertaining general reading on science, you may like to read some of the following books. Remember however, that many of these books are written at a level far beyond the level of the present book.

1. **Mr. Tompkins** in paperback, G. Gamow, Cambridge University Press (1967).
2. **The Universe and Dr. Einstein**, C. Barnett, Time Inc. New York (1962).
3. **Thirty years that Shook Physics**, G. Gamow, Double Day, New York (1966).
4. **Surely You're Joking, Mr. Feynman**, R.P. Feynman, Bantam books (1986).
5. **One, Two, Three... Infinity**, G. Gamow, Viking Inc. (1961).
6. **The Meaning of Relativity**, A. Einstein, (Indian Edition) Oxford and IBH Pub. Co (1965).
7. **Atomic Theory and the Description of Nature**, Niels Bohr, Cambridge (1934).
8. **The Physical Principles of Quantum Theory**, W. Heisenberg, University of Chicago Press (1930).
9. **The Physics- Astronomy Frontier**, F. Hoyle and J.V. Narlikar, W.H. Freeman (1980).
10. **The Flying Circus of Physics with Answer**, J. Walker, John Wiley and Sons (1977).
11. **Physics for Everyone** (series), L.D. Landau and A.I. Kitaigorodski, MIR Publisher (1978).  
 Book 1: Physical Bodies  
 Book 2: Molecules  
 Book 3: Electrons  
 Book 4: Photons and Nuclei.
12. **Physics can be Fun**, Y. Perelman, MIR Publishers (1986).
13. **Power of Ten**, Philip Morrison and Eames, W.H. Freeman (1985).
14. **Physics in your Kitchen Lab.**, I.K. Kikoin, MIR Publishers (1985).
15. **How Things Work : The Physics of Everyday Life**, Louis A. Bloomfield, John Wiley (2005)
16. **Physics Matters : An Introduction to Conceptual Physics**, James Trefil and Robert M. Hazen, John Wiley (2004).

## INDEX

### A

Absolute scale temperature	280
Absolute zero	280
Acceleration (linear)	45
Acceleration due to gravity	49, 189
Accuracy	22
Action-reaction	97
Addition of vectors	67
Adiabatic process	311, 312
Aerofoil	262
Air resistance	79
Amplitude	344, 372
Angle of contact	267, 268
Angstrom	21
Angular Acceleration	154
Angular displacement	342
Angular frequency	344, 373
Angular momentum	155
Angular velocity	152
Angular wave number	372
Antinodes	381, 382
Archimedes Principle	255
Area expansion	281
Atmospheric pressure	253
Average acceleration	45, 74
Average speed	42
Average velocity	42
Avogadro's law	325

### B

Banked road	104
Barometer	254
Beat frequency	383
Beats	382, 383
Bending of beam	244
Bernoulli's Principle	258
Blood pressure	276
Boiling point	287
Boyle's law	326
Buckling	244

Bulk modulus	242
Buoyant force	255

### C

Calorimeter	285
Capillary rise	268
Capillary waves	370
Carnot engine	316
Central forces	186
Centre of Gravity	161
Centre of mass	144
Centripetal acceleration	81
Centripetal force	104
Change of state	287
Charle's law	326
Chemical Energy	126
Circular motion	104
Clausius statement	315
Coefficient of area expansion	283
Coefficient of linear expansion	281
Coefficient of performance	314
Coefficient of static friction	101
Coefficient of viscosity	262
Coefficient of volume expansion	281
Cold reservoir	313
Collision	129
Collision in two dimensions	131
Compressibility	242, 243
Compressions	368, 369, 374
Compressive stress	236, 243
Conduction	290
Conservation laws	12
Conservation of angular momentum	157, 173
Conservation of Mechanical Energy	121
Conservation of momentum	98
Conservative force	121
Constant acceleration	46, 75
Contact force	100
Convection	293
Couple	159
Crest	371
Cyclic process	312

<b>D</b>			
Dalton's law of partial pressure	325	Geostationary satellite	196
Damped oscillations	355	Gravitational constant	189
Damped simple Harmonic motion	355	Gravitational Force	8, 192
Damping constant	355	Gravitational potential energy	191
Damping force	355	Gravity waves	370
Derived units	16		
Detergent action	269	<b>H</b>	
Diastolic pressure	277	Harmonic frequency	380, 381
Differential calculus	61	Harmonics	380, 381
Dimensional analysis	32	Heat capacity	284
Dimensions	31	Heat engines	313
Displacement vector	66	Heat pumps	313
Displacement	40	Heat	279
Doppler effect	385, 386	Heliocentric model	183
Doppler shift	387	Hertz	343
Driving frequency	358	Hooke's law	238
Dynamics of rotational motion	169	Horizontal range	78
		Hot reservoir	313
		Hydraulic brakes	255, 256
		Hydraulic lift	255, 256
		Hydraulic machines	255
		Hydraulic pressure	238
		Hydraulic stress	238, 243
		Hydrostatic paradox	253
<b>E</b>			
Efficiency of heat engine	313	<b>I</b>	
Elastic Collision	129	Ideal gas equation	280
Elastic deformation	236, 238	Ideal gas	280, 325
Elastic limit	238	Impulse	96
Elastic moduli	239	Inelastic collision	129
Elasticity	235	Initial phase angle	372
Elastomers	239	Instantaneous acceleration	74
Electromagnetic force	8	Instantaneous speed	45
Energy	117	Instantaneous velocity	43
Equality of vectors	66	Interference	377
Equation of continuity	257	Internal energy	306, 330
Equilibrium of a particle	99	Irreversible engine	315, 317
Equilibrium of Rigid body	158	Irreversible processes	315
Equilibrium position	341, 342, 353	Isobaric process	311, 312
Errors in measurement	22	Isochoric process	311, 312
Escape speed	193	Isotherm	310
		Isothermal process	311
<b>F</b>			
First law of Thermodynamics	307	<b>K</b>	
Fluid pressure	251	Kelvin-Planck statement	315
Force	94	Kepler's laws of planetary motion	184
Forced frequency	357	Kinematics of Rotational Motion	167
Forced oscillations	357, 358	Kinematics	39
Fracture point	238	Kinetic energy of rolling motion	174
Free Fall	49	Kinetic Energy	117
Free-body diagram	100	Kinetic interpretation of temperature	329
Frequency of periodic motion	342, 372	Kinetic theory of gases	328
Friction	101		
Fundamental Forces	6	<b>L</b>	
Fundamental mode	381	Laminar flow	258, 264
Fusion	287	Laplace correction	376
<b>G</b>			
Gauge pressure	253		
Geocentric model	183		

- |   |               |          |  |
|---|---------------|----------|--|
| Latent heat of fusion                             | 290           |          |  |
| Latent heat of vaporisation                       | 290           |          |  |
| Latent heat                                       | 289           |          |  |
| Law of cosine                                     | 72            |          |  |
| Law of equipartition of energy                    | 332           |          |  |
| Law of Inertia                                    | 90            |          |  |
| Law of sine                                       | 72            |          |  |
| Linear expansion                                  | 281           |          |  |
| Linear harmonic oscillator                        | 349, 351      |          |  |
| Linear momentum                                   | 155           |          |  |
| Longitudinal strain                               | 236           |          |  |
| Longitudinal strain                               | 236, 239      |          |  |
| Longitudinal stress                               | 236           |          |  |
| Longitudinal Wave                                 | 369, 376      |          |  |
| <b>M</b>  |               |          |  |
| Magnus effect                                     | 261           |          |  |
| Manometer   | 254           |          |  |
| Mass Energy Equivalence                           | 126           |          |  |
| Maximum height of projectile                      | 78            |          |  |
| Maxwell Distribution                              | 331           |          |  |
| Mean free path                                    | 324, 335      |          |  |
| Measurement of length                             | 18            |          |  |
| Measurement of mass                               | 21            |          |  |
| Measurement of temperature                        | 279           |          |  |
| Measurement of time                               | 22            |          |  |
| Melting point                                     | 286           |          |  |
| Modes   | 380           |          |  |
| Modulus of elasticity                             | 238           |          |  |
| Modulus of rigidity                               | 242           |          |  |
| Molar specific heat capacity at constant pressure | 284, 308      |          |  |
| Molar specific heat capacity at constant volume   | 284, 308      |          |  |
| Molar specific heat capacity                      | 284           |          |  |
| Molecular nature of matter                        | 323           |          |  |
| Moment of Inertia                                 | 163           |          |  |
| Momentum  | 93            |          |  |
| Motion in a plane                                 | 72            |          |  |
| Multiplication of vectors                         | 67            |          |  |
| Musical instruments                               | 384           |          |  |
| <b>N</b>  |               |          |  |
| Natural frequency                                 | 358           |          |  |
| Newton's first law of motion                      | 91            |          |  |
| Newton's Law of cooling                           | 295           |          |  |
| Newton's law of gravitation                       | 185           |          |  |
| Newton's second law of motion                     | 93            |          |  |
| Newton's third law of motion                      | 96            |          |  |
| Newtons' formula for speed of sound               | 377           |          |  |
| Nodes   | 381           |          |  |
| Normal Modes                                      | 381, 382, 384 |          |  |
| Note  | 384, 385      |          |  |
| Nuclear Energy                                    | 126           |          |  |
| Null vector                                       | 68            |          |  |
| <b>O</b>  |               |          |  |
| Odd harmonics                                     |               | 382      |  |
| Orbital velocity/speed                            |               | 194      |  |
| Order of magnitude                                |               | 28       |  |
| Oscillations                                      |               | 342      |  |
| Oscillatory motion                                |               | 342      |  |
| <b>P</b>  |               |          |  |
| Parallax method                                   |               | 18       |  |
| Parallelogram law of addition of vectors          |               | 66       |  |
| Pascal's law                                      |               | 252      |  |
| Path length                                       |               | 40       |  |
| Path of projectile                                |               | 78       |  |
| Periodic force                                    |               | 358      |  |
| Periodic motion                                   |               | 342      |  |
| Periodic time                                     |               | 342      |  |
| Permanent set                                     |               | 238      |  |
| Phase angle                                       |               | 344      |  |
| Phase constant                                    |               | 344      |  |
| Pipe open at both ends                            |               | 382      |  |
| Pipe open at one end                              |               | 381      |  |
| Pitch   |               | 384      |  |
| Plastic deformation                               |               | 238      |  |
| Plasticity  |               | 235      |  |
| Polar satellite                                   |               | 196      |  |
| Position vector and displacement                  |               | 73       |  |
| Potential energy of a spring                      |               | 123      |  |
| Potential energy                                  |               | 120      |  |
| Power   |               | 128      |  |
| Precession  |               | 143      |  |
| Pressure gauge                                    |               | 253      |  |
| Pressure of an ideal gas                          |               | 328      |  |
| Pressure  |               | 250      |  |
| Principle of Conservation of Energy               |               | 128      |  |
| Principle of moments                              |               | 160      |  |
| Progressive wave                                  |               | 373      |  |
| Projectile motion                                 |               | 77       |  |
| Projectile  |               | 77       |  |
| Propagation constant                              |               | 371      |  |
| Pulse   |               | 369      |  |
| <b>Q</b>  |               |          |  |
| Quasi-static process                              |               | 310, 311 |  |
| <b>R</b>  |               |          |  |
| Radiation   |               | 294      |  |
| Radius of Gyration                                |               | 164      |  |
| Raman effect                                      |               | 11       |  |
| Rarefactions                                      |               | 369      |  |
| Ratio of specific heat capacities                 |               | 334      |  |
| Reaction time                                     |               | 51       |  |
| Real gases  |               | 326      |  |
| Rectilinear motion                                |               | 39       |  |
| Reductionism                                      |               | 2        |  |
| Reflected wave                                    |               | 379      |  |
| Reflection of waves                               |               | 378      |  |

Refracted wave	379	Surface tension	265
Refrigerator	313	Symmetry	146
Regelation	287	System of units	16
Relative velocity in two dimensions	76	Systolic pressure	277
Relative velocity	51		
Resolution of vectors	69	<b>T</b>	
Resonance	358	Temperature	279
Restoring force	236, 350, 369	Tensile strength	238
Reversible engine	316, 317	Tensile stress	236
Reversible processes	315	Terminal velocity	264
Reynolds number	264	Theorem of parallel axes	167
Rigid body	141	Theorem of perpendicular axes	165
Rolling motion	173	Thermal conductivity	291
Root mean square speed	329	Thermal equilibrium	304
Rotation	142	Thermal expansion	281
		Thermal stress	284
<b>S</b>		Thermodynamic processes	310
S.H.M. (Simple Harmonic Motion)	343	Thermodynamic state variables	309
Scalar-product	114	Thermodynamics	3, 303
Scalars	65	Time of flight	78
Scientific Method	1	Torque	154
Second law of Thermodynamics	314	Toricelli's Law	259, 260
Shear modulus	242	Trade wind	294
Shearing strain	237	Transmitted wave	379
Shearing stress	237, 243	Travelling wave	380
SI units	16	Triangle law of addition of vectors	66
Significant figures	27	Triple point	288
Simple pendulum	343, 353	Trough	371
Soap bubbles	268	Tune	384
Sonography	387	Turbulent flow	258, 259
Sound	375		
Specific heat capacity of Solids	308, 335	<b>U</b>	
Specific heat capacity of Gases	333, 334	Ultimate strength	238
Specific heat capacity of Water	335	Ultrasonic waves	387
Specific heat capacity	285, 308	Unification of Forces	10
Speed of efflux	259	Unified Atomic Mass Unit	21
Speed of Sound	375, 376	Uniform circular motion	79
Speed of Transverse wave	375, 376	Uniform Motion	41
on a stretched string		Uniformly accelerated motion	47
Sphygmomanometer	277	Unit vectors	70
Spring constant	352, 355		
Standing waves	380	<b>V</b>	
Stationary waves	382	Vane	356
Steady flow	257	Vaporisation	288
Stethoscope	281	Vector-product	151
Stokes' law	263	Vectors	66
Stopping distance	50	Velocity amplitude	349
Strain	236	Venturi meter	260
Streamline flow	257, 258	Vibration	341
Streamline	257, 258	Viscosity	262
Stress	236	Volume expansion	281
Stress-strain curve	238	Volume Strain	238
Stretched string	374		
Sublimation	294	<b>W</b>	
Subtraction of vectors	67	Wave equation	374
Superposition principle	378	Wavelength	372
Surface energy	265	Wave speed	374

Waves	368	<b>Y</b>	
Waxing and waning of sound	385	Yield Point	238
Weak nuclear force	9	Yield strength	238
Weightlessness	197	Young's modulus	239
Work done by variable force	118	<b>Z</b>	
Work	116	Zeroth law of Thermodynamics	305
Work-Energy Theorem	116		
Working substance	313		

© NCERT  
not to be republished

# NOTES

© NCERT  
not to be republished

# PHYSICS

PART II

TEXTBOOK FOR CLASS XI



11087

विद्यया ऽ मृतमश्नुते



एन सी ई आर टी  
NCERT

राष्ट्रीय शैक्षिक अनुसंधान और प्रशिक्षण परिषद्  
NATIONAL COUNCIL OF EDUCATIONAL RESEARCH AND TRAINING



**11087 – PHYSICS (PART II)**

Textbook for Class XI

ISBN 81-7450-508-3 (Part-I)

ISBN 81-7450-566-0 (Part-II)

**First Edition**

April 2006 Chaitra 1928

**Reprinted**

October 2006, February 2008,  
January 2009, January 2010,  
January 2012, January 2013,  
January 2014, January 2015,  
May 2016, February 2017,  
December 2017, January 2019,  
October 2019, January 2021,  
July 2021 and March 2022

**Revised Edition**

January 2023 Pausha 1944

**Reprinted**

March 2024 Chaitra 1946

**PD 350T SU**

© National Council of Educational  
Research and Training, 2006, 2023

₹ 145.00

Printed on 80 GSM paper with NCERT  
watermark

Published at the Publication Division by the  
Secretary, National Council of Educational  
Research and Training, Sri Aurobindo  
Marg, New Delhi 110016 and printed at Fauji  
Printing Press, Khasra. No. 24/20 Nangli  
Shakrawati Industrial Area, Najafgarh,  
New Delhi- 110 043

**ALL RIGHTS RESERVED**

- No part of this publication may be reproduced, stored in a retrieval system or transmitted, in any form or by any means, electronic, mechanical, photocopying, recording or otherwise without the prior permission of the publisher.
- This book is sold subject to the condition that it shall not, by way of trade, be lent, re-sold, hired out or otherwise disposed of without the publisher's consent, in any form of binding or cover other than that in which it is published.
- The correct price of this publication is the price printed on this page. Any revised price indicated by a rubber stamp or by a sticker or by any other means is incorrect and should be unacceptable.

**OFFICES OF THE PUBLICATION****DIVISION, NCERT**

NCERT Campus  
Sri Aurobindo Marg  
New Delhi 110 016

Phone : 011-26562708

108, 100 Feet Road  
Hosdakere Halli Extension  
Banashankari III Stage  
Bengaluru 560 085

Phone : 080-26725740

Navjivan Trust Building  
P.O. Navjivan  
Ahmedabad 380 014

Phone : 079-27541446

CWC Campus  
Opp. Dhankal Bus Stop  
Panihati  
Kolkata 700 114

Phone : 033-25530454

CWC Complex  
Maligaon  
Guwahati 781 021

Phone : 0361-2674869

**Publication Team**

Head, Publication Division : Anup Kumar Rajput  
Chief Editor : Shweta Uppal  
Chief Production Officer : Arun Chitkara  
Chief Business Manager (In charge) : Amitabh Kumar  
Assistant Editor : R.N. Bhardwaj  
Assistant Production Officer : Om Prakash

**Cover and Illustrations**

Shweta Rao

## FOREWORD

The National Curriculum Framework (NCF), 2005 recommends that children's life at school must be linked to their life outside the school. This principle marks a departure from the legacy of bookish learning which continues to shape our system and causes a gap between the school, home and community. The syllabi and textbooks developed on the basis of NCF signify an attempt to implement this basic idea. They also attempt to discourage rote learning and the maintenance of sharp boundaries between different subject areas. We hope these measures will take us significantly further in the direction of a child-centred system of education outlined in the National Policy on Education (1986).

The success of this effort depends on the steps that school principals and teachers will take to encourage children to reflect on their own learning and to pursue imaginative activities and questions. We must recognise that, given space, time and freedom, children generate new knowledge by engaging with the information passed on to them by adults. Treating the prescribed textbook as the sole basis of examination is one of the key reasons why other resources and sites of learning are ignored. Inculcating creativity and initiative is possible if we perceive and treat children as participants in learning, not as receivers of a fixed body of knowledge.

These aims imply considerable change in school routines and mode of functioning. Flexibility in the daily time-table is as necessary as rigour in implementing the annual calendar so that the required number of teaching days are actually devoted to teaching. The methods used for teaching and evaluation will also determine how effective this textbook proves for making children's life at school a happy experience, rather than a source of stress or boredom. Syllabus designers have tried to address the problem of curricular burden by restructuring and reorienting knowledge at different stages with greater consideration for child psychology and the time available for teaching. The textbook attempts to enhance this endeavour by giving higher priority and space to opportunities for contemplation and wondering, discussion in small groups, and activities requiring hands-on experience.

The National Council of Educational Research and Training (NCERT) appreciates the hard work done by the textbook development committee responsible for this book. We wish to thank the Chairperson of the advisory group in science and mathematics, Professor J.V. Narlikar and the Chief Advisor for this book, Professor A.W. Joshi for guiding the work of this committee. Several teachers contributed to the development of this textbook; we are grateful to their principals for making this possible. We are indebted to the institutions and organisations which have generously permitted us to draw upon their resources, material and personnel. We are especially grateful to the members of the National Monitoring Committee, appointed by the Department of Secondary and Higher Education, Ministry of Human Resource Development under the Chairpersonship of Professor Mrinal Miri and Professor G.P. Deshpande, for their valuable time and contribution. As an organisation committed to systemic reform and continuous improvement in the quality of its products, NCERT welcomes comments and suggestions which will enable us to undertake further revision and refinement.

New Delhi  
20 December 2005

*Director*  
National Council of Educational  
Research and Training

© NCERT  
not to be republished

## RATIONALISATION OF CONTENT IN THE TEXTBOOKS

In view of the COVID-19 pandemic, it is imperative to reduce content load on students. The National Education Policy 2020, also emphasises reducing the content load and providing opportunities for experiential learning with creative mindset. In this background, the NCERT has undertaken the exercise to rationalise the textbooks across all classes. Learning Outcomes already developed by the NCERT across classes have been taken into consideration in this exercise.

### **Contents of the textbooks have been rationalised in view of the following:**

- Overlapping with similar content included in other subject areas in the same class
- Similar content included in the lower or higher class in the same subject
- Difficulty level
- Content, which is easily accessible to students without much interventions from teachers and can be learned by children through self-learning or peer-learning
- Content, which is irrelevant in the present context

**This present edition, is a reformatted version after carrying out the changes given above.**

© NCERT  
not to be republished

## PREFACE

More than a decade ago, based on National Policy of Education (NPE-1986), National Council of Educational Research and Training published physics textbooks for Classes XI and XII, prepared under the chairmanship of Professor T. V. Ramakrishnan, F.R.S., with the help of a team of learned co-authors. The books were well received by the teachers and students alike. The books, in fact, proved to be milestones and trend-setters. However, the development of textbooks, particularly science books, is a dynamic process in view of the changing perceptions, needs, feedback and the experiences of the students, educators and the society. Another version of the physics books, which was the result of the revised syllabus based on *National Curriculum Framework for School Education-2000* (NCFSE-2000), was brought out under the guidance of Professor Suresh Chandra, which continued up to now. Recently the NCERT brought out the *National Curriculum Framework-2005* (NCF-2005), and the syllabus was accordingly revised during a curriculum renewal process at school level. The higher secondary stage syllabus (NCERT, 2005) has been developed accordingly. The Class XI textbook contains fifteen chapters in two parts. Part I contains first eight chapters while Part II contains next seven chapters. This book is the result of the renewed efforts of the present Textbook Development Team with the hope that the students will appreciate the beauty and logic of physics. The students may or may not continue to study physics beyond the higher secondary stage, but we feel that they will find the thought process of physics useful in any other branch they may like to pursue, be it finance, administration, social sciences, environment, engineering, technology, biology or medicine. For those who pursue physics beyond this stage, the matter developed in these books will certainly provide a sound base.

Physics is basic to the understanding of almost all the branches of science and technology. It is interesting to note that the ideas and concepts of physics are increasingly being used in other branches such as economics and commerce, and behavioural sciences too. We are conscious of the fact that some of the underlying simple basic physics principles are often conceptually quite intricate. In this book, we have tried to bring in a conceptual coherence. The pedagogy and the use of easily understandable language are at the core of our effort without sacrificing the **rigour** of the subject. The nature of the subject of physics is such that a certain minimum use of mathematics is a must. We have tried to develop the mathematical formulations in a logical fashion, as far as possible.

Students and teachers of physics must realise that physics is a branch which needs to be understood, not necessarily memorised. As one goes from secondary to higher secondary stage and beyond, physics involves mainly four components, (a) large amount of **mathematical base**, (b) **technical words and terms**, whose normal English meanings could be quite different, (c) new **intricate concepts**, and (d) **experimental foundation**. Physics needs mathematics because we wish to develop objective description of the world around us and express our observations in terms of measurable quantities. Physics discovers new properties of particles and wants to create a name for each one. The words are picked up normally from common English or Latin or Greek, but gives entirely different meanings to these words. It would be illuminating to look up words like energy, force, power, charge, spin, and several others, in any standard English dictionary, and compare their

meanings with their physics meanings. Physics develops intricate and often weird-looking concepts to explain the behaviour of particles. Finally, it must be remembered that entire physics is based on observations and experiments, without which a theory does not get acceptance into the domain of physics.

This book has some features which, we earnestly hope, will enhance its usefulness for the students. Each chapter is provided with a **Summary** at its end for a quick overview of the contents of the chapter. This is followed by **Points to Ponder** which points out the likely misconceptions arising in the minds of students, hidden implications of certain statements/principles given in the chapter and **cautions** needed in applying the knowledge gained from the chapter. They also raise some thought-provoking questions which would make a student think about life beyond physics. Students will find it interesting to think and apply their mind on these **points**. Further, a large number of **solved examples** are included in the text in order to clarify the concepts and/or to illustrate the application of these concepts in everyday real-life situations. Occasionally, historical perspective has been included to share the excitement of sequential development of the subject of physics. Some **Boxed** items are introduced in many chapters either for this purpose or to highlight some special features of the contents requiring additional attention of the learners. Finally, a **Subject Index** has been added at the end of the book for ease in locating keywords in the book.

The special nature of physics demands, apart from conceptual understanding, the knowledge of certain conventions, basic mathematical tools, numerical values of important physical constants, and systems of measurement units covering a vast range from microscopic to galactic levels. In order to equip the students, we have included the necessary tools and database in the form of **Appendices** A-1 to A-9 at the end of the book. There are also some other appendices at the end of some chapters giving additional information or applications of matter discussed in that chapter.

Special attention has been paid for providing illustrative figures. To increase the clarity, the figures are drawn in two colours. A large number of **Exercises** are given at the end of each chapter. Some of these are from real-life situations. Students are urged to solve these and in doing so, they may find them very educative. Moreover, some **Additional Exercises** are given which are more challenging. Answers and hints to solve some of these are also included. In the entire book, SI units have been used. A comprehensive account of 'units and measurement' is given in Chapter 2 as a part of prescribed syllabus/curriculum as well as a help in their pursuit of physics. A box-item in this chapter brings out the difficulty in measuring as simple a thing as the length of a long curved line. Tables of SI base units and other related units are given here merely to indicate the presently accepted definitions and to indicate the high degree of accuracy with which measurements are possible today. The numbers given here are not to be memorised or asked in examinations.

There is a perception among students, teachers, as well as the general public that there is a steep gradient between secondary and higher secondary stages. But a little thought shows that it is bound to be there in the present scenario of education. Education up to secondary stage is general education where a student has to learn several subjects – sciences, social sciences, mathematics, languages, at an elementary level. Education at the higher secondary stage and beyond, borders on acquiring professional competence, in some chosen fields of endeavour. You may like to compare this with the following situation. Children play cricket or badminton in lanes and small spaces outside (or inside) their homes. But then

some of them want to make it to the school team, then district team, then State team and then the National team. At every stage, there is bound to be a steep gradient. Hard work would have to be put in whether students want to pursue their education in the area of sciences, humanities, languages, music, fine arts, commerce, finance, architecture, or if they want to become sportspersons or fashion designers.

**Completing this book has only been possible because of the spontaneous and continuous support of many people. The Textbook Development Team is thankful to Dr. V. H. Raybagkar for allowing us to use his box item in Chapter 4 and to Dr. F. I. Surve for allowing us to use two of his box items in Chapter 15. We express also our gratitude to the Director, NCERT, for entrusting us with the task of preparing this textbook as a part of national effort for improving science education. The Head, Department of Education in Science and Mathematics, NCERT, was always willing to help us in our endeavour in every possible way.**

The previous text got excellent academic inputs from teachers, students and experts who sincerely suggested improvement during the past few years. We are thankful to all those who conveyed these inputs to NCERT. We are also thankful to the members of the Review Workshop and Editing Workshop organised to discuss and refine the first draft. We thank the Chairmen and their teams of authors for the text written by them in 1988, which provided the base and reference for developing the 2002 version as well as the present version of the textbook. Occasionally, substantial portions from the earlier versions, particularly those appreciated by students/teachers, have been adopted/adapted and retained in the present book for the benefit of coming generation of learners.

We welcome suggestions and comments from our valued users, especially students and teachers. We wish our young readers a happy journey to the exciting realm of physics.

A. W. JOSHI  
*Chief Advisor*  
Textbook Development Committee



## ACKNOWLEDGEMENTS

The National Council of Educational Research and Training acknowledges the valuable contribution of the individuals and organisations involved in the development of Physics textbook for Class XI. The Council also acknowledges the valuable contribution of the following academics for reviewing and refining the manuscripts of this book: Deepak Kumar, *Professor*, School of Physical Sciences, Jawaharlal Nehru University, New Delhi; Pankaj Sharan, *Professor*, Jamia Millia Islamia, New Delhi; Ajoy Ghatak, *Emeritus Professor*, Indian Institute of Technology, New Delhi; V. Sundara Raja, *Professor*, Sri Venkateswara University, Tirupati, Andhra Pradesh; C.S. Adgaonkar, *Reader (Retd)*, Institute of Science, Nagpur, Maharashtra; D.A. Desai, *Lecturer (Retd)*, Ruparel College, Mumbai, Maharashtra; F.I. Surve, *Lecturer*, Nowrosjee Wadia College, Pune, Maharashtra; Atul Mody, *Lecturer (SG)*, VES College of Arts, Science and Commerce, Chembur, Mumbai, Maharashtra; A.K. Das, *PGT*, St. Xavier's Senior Secondary School, Delhi; Suresh Kumar, *PGT*, Delhi Public School, Dwarka, New Delhi; Yashu Kumar, *PGT*, Kulachi Hansraj Model School, Ashok Vihar, Delhi; K.S. Upadhyay, *PGT*, Jawahar Navodaya Vidyalaya, Muzaffar Nagar (U.P.); I.K. Gogia, *PGT*, Kendriya Vidyalaya, Gole Market, New Delhi; Vijay Sharma, *PGT*, Vasant Valley School, Vasant Kunj, New Delhi; R.S. Dass, *Vice Principal (Retd)*, Balwant Ray Mehta Vidya Bhawan, Lajpat Nagar, New Delhi and Parthasarathi Panigrahi, *PGT*, D.V. CLW Girls School, Chittranjan, West Bengal.

The Council also gratefully acknowledges the valuable contribution of the following academics for the editing and finalisation of this book: A.S. Mahajan, *Professor (Retd)*, Indian Institute of Technology, Mumbai, Maharashtra; D.A. Desai, *Lecturer (Retd)*, Ruparel College, Mumbai, Maharashtra; V.H. Raybagkar, *Reader*, Nowrosjee Wadia College, Pune, Maharashtra and Atul Mody, *Lecturer (SG)*, VES College of Arts, Science and Commerce, Chembur, Mumbai, Maharashtra.

The Council also acknowledges the valuable contributions of the following academics for reviewing and refining the text in 2017: A.K. Srivastava, *DESM*, NCERT, New Delhi; Arnab Sen, *NERIE*, Shillong; L.S. Chauhan, *RIE*, Bhopal; O.N. Awasthi (*Retd.*), *RIE*, Bhopal; Rachna Garg, *DESM*, NCERT, New Delhi; Raman Namboodiri, *RIE*, Mysuru; R.R. Koireng, *DCS*, NCERT, New Delhi; Shashi Prabha, *DESM*, NCERT, New Delhi; and S.V. Sharma, *RIE*, Ajmer.

Special thanks are due to M. Chandra, *Professor and Head*, *DESM*, NCERT for her support.

The Council also acknowledges the efforts of Deepak Kapoor, *Incharge*, Computer Station, Inder Kumar, *DTP Operator*; Saswati Banerjee, *Copy Editor*; Abhimanu Mohanty and Anuradha, *Proof Readers* in shaping this book.

The contributions of the Publication Department in bringing out this book are also duly acknowledged.

## TEXTBOOK DEVELOPMENT COMMITTEE

### CHAIRPERSON, ADVISORY GROUP FOR TEXTBOOKS IN SCIENCE AND MATHEMATICS

J.V. Narlikar, *Emeritus Professor*, Chairman, Advisory Committee, Inter University Centre for Astronomy and Astrophysics (IUCCA), Ganeshbhind, Pune University, Pune

### CHIEF ADVISOR

A.W. Joshi, *Professor*, Honorary Visiting Scientist, NCRA, Pune (Formerly at Department of Physics, University of Pune)

### MEMBERS

Anuradha Mathur, *PGT*, Modern School, Vasant Vihar, New Delhi

Chitra Goel, *PGT*, Rajkiya Pratibha Vikas Vidyalaya, Tyagraj Nagar, Lodhi Road, New Delhi

Gagan Gupta, *Reader*, DESM, NCERT, New Delhi

H.C. Pradhan, *Professor*, Homi Bhabha Centre of Science Education, Tata Institute of Fundamental Research, V.N. Purav Marg, Mankhurd, Mumbai

N. Panchapakesan, *Professor (Retd.)*, Department of Physics and Astrophysics, University of Delhi, Delhi

P.K. Srivastava, *Professor (Retd.)*, Director, CSEC, University of Delhi, Delhi

P.K. Mohanty, *PGT*, Sainik School, Bhubaneswar

P.C. Agarwal, *Reader*, Regional Institute of Education, NCERT, Sachivalaya Marg, Bhubaneswar

R. Joshi, *Lecturer (S.G.)*, DESM, NCERT, New Delhi

S. Rai Choudhary, *Professor*, Department of Physics and Astrophysics, University of Delhi, Delhi

S.K. Dash, *Reader*, DESM, NCERT, New Delhi

Sher Singh, *PGT*, Lodhi Road, New Delhi

S.N. Prabhakara, *PGT*, DM School, Regional Institute of Education, NCERT, Mysore

Thiyam Jekendra Singh, *Professor*, Department of Physics, University of Manipur, Imphal

V.P. Srivastava, *Reader*, DESM, NCERT, New Delhi

### MEMBER-COORDINATOR

B.K. Sharma, *Professor*, DESM, NCERT, New Delhi

## COVER DESIGN

(Adapted from the website of the Nobel Foundation  
<http://www.nobelprize.org>)

---

*The strong nuclear force binds protons and neutrons in a nucleus and is the strongest of nature's four fundamental forces. A mystery surrounding the strong nuclear force has been solved. The three quarks within the proton can sometimes appear to be free, although no free quarks have ever been observed. The quarks have a quantum mechanical property called 'colour' and interact with each other through the exchange of particles called 'gluons' — nature glue.*

---

## BACK COVER

(Adapted from the website of the ISRO  
<http://www.isro.gov.in>)

---

*CARTOSAT-1 is a state-of-the-art Remote Sensing Satellite, being eleventh one in the Indian Remote Sensing (IRS) Satellite Series, built by ISRO. CARTOSAT-1, having mass of 156 kg at lift off, has been launched into a 618 km high polar Sun Synchronous Orbit (SSO) by ISRO's Polar Satellite Launch Vehicle, PSLV-C6. It is mainly intended for cartographic applications.*

---

## A NOTE FOR THE TEACHERS

To make the curriculum learner-centred, students should be made to participate and interact in the learning process directly. Once a week or one out of every six classes would be a good periodicity for such seminars and mutual interaction. Some suggestions for making the discussion participatory are given below, with reference to some specific topics in this book.

Students may be divided into groups of five to six. The membership of these groups may be rotated during the year, if felt necessary.

The topic for discussion can be presented on the board or on slips of paper. Students should be asked to write their reactions or answers to questions, whichever is asked, on the given sheets. They should then discuss in their groups and add modifications or comments in those sheets. These should be discussed either in the same or in a different class. The sheets may also be evaluated.

We suggest here three possible topics from the book. The first two topics suggested are, in fact, very general and refer to the development of science over the past four centuries or more. Students and teachers may think of more such topics for each seminar.

### 1. Ideas that changed civilisation

Suppose human beings are becoming extinct. A message has to be left for future generations or alien visitors. Eminent physicist R P Feynmann wanted the following message left for future beings, if any.

**“Matter is made up of atoms”**

A lady student and teacher of literature, wanted the following message left:

**“Water existed, so human beings could happen”.**

Another person thought it should be: **“Idea of wheel for motion”**

Write down what message each one of you would like to leave for future generations. Then discuss it in your group and add or modify, if you want to change your mind. Give it to your teacher and join in any discussion that follows.

### 2. Reductionism

Kinetic Theory of Gases relates the Big to the Small, the Macro to the Micro. A gas as a system is related to its components, the molecules. This way of describing a system as a result of the properties of its components is usually called **Reductionism**. It explains the behaviour of the group by the simpler and predictable behaviour of individuals. Macroscopic observations and microscopic properties have a mutual interdependence in this approach. Is this method useful?

This way of understanding has its limitations outside physics and chemistry, may be even in these subjects. A painting **cannot** be discussed as a collection of the properties of chemicals used in making the canvas and the painting. What emerges is more than the sum of its components.

**Question:** Can you think of other areas where such an approach is used?

Describe briefly a system which is fully describable in terms of its components. Describe one which is not. Discuss with other members of the group and write your views. Give it to your teacher and join in any discussion that may follow.

### 3. Molecular approach to heat

Describe what you think will happen in the following case. An enclosure is separated by a porous wall into two parts. One is filled with nitrogen gas ( $N_2$ ) and the other with  $CO_2$ . Gases will diffuse from one side to the other.

**Question 1:** Will both gases diffuse to the same extent? If not, which will diffuse more. Give reasons.

**Question 2:** Will the pressure and temperature be unchanged? If not, what will be the changes in both. Give reasons.

Write down your answers. Discuss with the group and modify them or add comments. Give to the teacher and join in the discussion.

Students and teachers will find that such seminars and discussions lead to tremendous understanding, not only of physics, but also of science and social sciences. They also bring in some maturity among students.

## CONTENTS OF PHYSICS PART I

<b>CHAPTER 1</b> <b>UNITS AND MEASUREMENTS</b>	1
<b>CHAPTER 2</b> <b>MOTION IN A STRAIGHT LINE</b>	13
<b>CHAPTER 3</b> <b>MOTION IN A PLANE</b>	37
<b>CHAPTER 4</b> <b>LAWS OF MOTION</b>	49
<b>CHAPTER 5</b> <b>WORK, ENERGY AND POWER</b>	71
<b>CHAPTER 6</b> <b>SYSTEM OF PARTICLES AND ROTATIONAL MOTION</b>	92
<b>CHAPTER 7</b> <b>GRAVITATION</b>	127
<b>APPENDICES</b>	144
<b>ANSWERS</b>	160

# CONTENTS

---

---

<b>FOREWORD</b>	<i>iii</i>
<b>RATIONALISATION OF CONTENTS IN THE TEXTBOOKS</b>	<i>v</i>
<b>PREFACE</b>	<i>vii</i>
<b>A NOTE FOR THE TEACHERS</b>	<i>xiii</i>
<b>C H A P T E R   8</b>	
<b>MECHANICAL PROPERTIES OF SOLIDS</b>	
<b>8.1</b> Introduction	167
<b>8.2</b> Stress and strain	168
<b>8.3</b> Hooke's law	169
<b>8.4</b> Stress-strain curve	169
<b>8.5</b> Elastic moduli	170
<b>8.6</b> Applications of elastic behaviour of materials	174
<b>C H A P T E R   9</b>	
<b>MECHANICAL PROPERTIES OF FLUIDS</b>	
<b>9.1</b> Introduction	180
<b>9.2</b> Pressure	180
<b>9.3</b> Streamline flow	186
<b>9.4</b> Bernoulli's principle	187
<b>9.5</b> Viscosity	190
<b>9.6</b> Surface tension	192
<b>C H A P T E R   10</b>	
<b>THERMAL PROPERTIES OF MATTER</b>	
<b>10.1</b> Introduction	202
<b>10.2</b> Temperature and heat	202
<b>10.3</b> Measurement of temperature	203
<b>10.4</b> Ideal-gas equation and absolute temperature	203
<b>10.5</b> Thermal expansion	204
<b>10.6</b> Specific heat capacity	208
<b>10.7</b> Calorimetry	209
<b>10.8</b> Change of state	210
<b>10.9</b> Heat transfer	214
<b>10.10</b> Newton's law of cooling	219
<b>C H A P T E R   11</b>	
<b>THERMODYNAMICS</b>	
<b>11.1</b> Introduction	226
<b>11.2</b> Thermal equilibrium	227
<b>11.3</b> Zeroth law of thermodynamics	228
<b>11.4</b> Heat, internal energy and work	229
<b>11.5</b> First law of thermodynamics	230
<b>11.6</b> Specific heat capacity	231

<b>11.7</b>	Thermodynamic state variables and equation of state	232
<b>11.8</b>	Thermodynamic processes	233
<b>11.9</b>	Second law of thermodynamics	236
<b>11.10</b>	Reversible and irreversible processes	236
<b>11.11</b>	Carnot engine	237

## **C H A P T E R 12**

### **KINETIC THEORY**

<b>12.1</b>	Introduction	244
<b>12.2</b>	Molecular nature of matter	244
<b>12.3</b>	Behaviour of gases	246
<b>12.4</b>	Kinetic theory of an ideal gas	248
<b>12.5</b>	Law of equipartition of energy	252
<b>12.6</b>	Specific heat capacity	253
<b>12.7</b>	Mean free path	254

## **C H A P T E R 13**

### **OSCILLATIONS**

<b>13.1</b>	Introduction	259
<b>13.2</b>	Periodic and oscillatory motions	260
<b>13.3</b>	Simple harmonic motion	262
<b>13.4</b>	Simple harmonic motion and uniform circular motion	264
<b>13.5</b>	Velocity and acceleration in simple harmonic motion	266
<b>13.6</b>	Force law for simple harmonic motion	267
<b>13.7</b>	Energy in simple harmonic motion	268
<b>13.8</b>	The Simple Pendulum	270

## **C H A P T E R 14**

### **WAVES**

<b>14.1</b>	Introduction	278
<b>14.2</b>	Transverse and longitudinal waves	280
<b>14.3</b>	Displacement relation in a progressive wave	281
<b>14.4</b>	The speed of a travelling wave	284
<b>14.5</b>	The principle of superposition of waves	287
<b>14.6</b>	Reflection of waves	288
<b>14.7</b>	Beats	293

<b>ANSWERS</b>	300
----------------	-----

<b>BIBLIOGRAPHY</b>	307
---------------------	-----

<b>INDEX</b>	309
--------------	-----



## MECHANICAL PROPERTIES OF SOLIDS

- 8.1 Introduction
  - 8.2 Stress and strain
  - 8.3 Hooke's law
  - 8.4 Stress-strain curve
  - 8.5 Elastic moduli
  - 8.6 Applications of elastic behaviour of materials
- Summary  
Points to ponder  
Exercises

### 8.1 INTRODUCTION

In Chapter 6, we studied the rotation of the bodies and then realised that the motion of a body depends on how mass is distributed within the body. We restricted ourselves to simpler situations of rigid bodies. A rigid body generally means a hard solid object having a definite shape and size. But in reality, bodies can be stretched, compressed and bent. Even the appreciably rigid steel bar can be deformed when a sufficiently large external force is applied on it. This means that solid bodies are not perfectly rigid.

A solid has definite shape and size. In order to change (or deform) the shape or size of a body, a force is required. If you stretch a helical spring by gently pulling its ends, the length of the spring increases slightly. When you leave the ends of the spring, it regains its original size and shape. The property of a body, by virtue of which it tends to regain its original size and shape when the applied force is removed, is known as **elasticity** and the deformation caused is known as **elastic** deformation. However, if you apply force to a lump of putty or mud, they have no gross tendency to regain their previous shape, and they get permanently deformed. Such substances are called **plastic** and this property is called **plasticity**. Putty and mud are close to ideal plastics.

The elastic behaviour of materials plays an important role in engineering design. For example, while designing a building, knowledge of elastic properties of materials like steel, concrete etc. is essential. The same is true in the design of bridges, automobiles, ropeways etc. One could also ask — Can we design an aeroplane which is very light but sufficiently strong? Can we design an artificial limb which is lighter but stronger? Why does a railway track have a particular shape like **I**? Why is glass brittle while brass is not? Answers to such questions begin with the study of how relatively simple kinds of loads or forces act to deform different solids bodies. In this chapter, we shall study the



elastic behaviour and mechanical properties of solids which would answer many such questions.

## 8.2 STRESS AND STRAIN

When forces are applied on a body in such a manner that the body is still in static equilibrium, it is deformed to a small or large extent depending upon the nature of the material of the body and the magnitude of the deforming force. The deformation may not be noticeable visually in many materials but it is there. When a body is subjected to a deforming force, a restoring force is developed in the body. This restoring force is equal in magnitude but opposite in direction to the applied force. The restoring force per unit area is known as **stress**. If  $F$  is the force applied normal to the cross-section and  $A$  is the area of cross section of the body,

$$\text{Magnitude of the stress} = F/A \quad (8.1)$$

The SI unit of stress is  $\text{N m}^{-2}$  or pascal (Pa) and its dimensional formula is  $[ML^{-1}T^{-2}]$ .

There are three ways in which a solid may change its dimensions when an external force acts on it. These are shown in Fig. 8.1. In Fig. 8.1(a), a cylinder is stretched by two equal forces applied normal to its cross-sectional area. The restoring force per unit area in this case is called **tensile stress**. If the cylinder is compressed under the action of applied forces, the restoring force per unit area is known as **compressive stress**. Tensile or compressive stress can also be termed as longitudinal stress.

In both the cases, there is a change in the length of the cylinder. The change in the length  $\Delta L$  to the original length  $L$  of the body (cylinder in this case) is known as **longitudinal strain**.

$$\text{Longitudinal strain} = \frac{\Delta L}{L} \quad (8.2)$$

However, if two equal and opposite deforming forces are applied parallel to the cross-sectional area of the cylinder, as shown in Fig. 8.1(b), there is relative displacement between the opposite faces of the cylinder. The restoring force per unit area developed due to the applied tangential force is known as **tangential** or **shearing stress**.

As a result of applied tangential force, there is a relative displacement  $\Delta x$  between opposite faces of the cylinder as shown in the Fig. 8.1(b). The strain so produced is known as **shearing strain** and it is defined as the ratio of relative displacement of the faces  $\Delta x$  to the length of the cylinder  $L$ .

$$\text{Shearing strain} = \frac{\Delta x}{L} = \tan \theta \quad (8.3)$$

where  $\theta$  is the angular displacement of the cylinder from the vertical (original position of the cylinder). Usually  $\theta$  is very small,  $\tan \theta$  is nearly equal to angle  $\theta$ , (if  $\theta = 10^\circ$ , for example, there is only 1% difference between  $\theta$  and  $\tan \theta$ ).

It can also be visualised, when a book is pressed with the hand and pushed horizontally, as shown in Fig. 8.2 (c).

$$\text{Thus, shearing strain} = \tan \theta \approx \theta \quad (8.4)$$

In Fig. 8.1 (d), a solid sphere placed in the fluid under high pressure is compressed uniformly on all sides. The force applied by the fluid acts in perpendicular direction at each point of the surface and the body is said to be under hydraulic compression. This leads to decrease

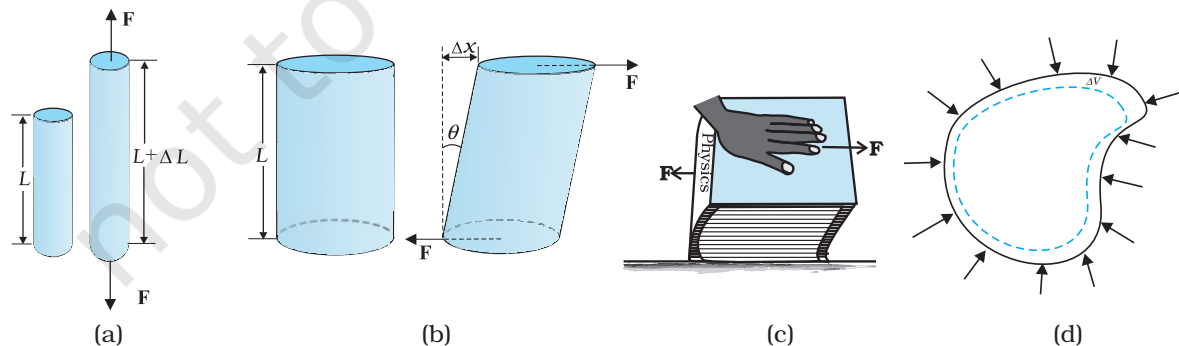

**Fig. 8.1** (a) A cylindrical body under tensile stress elongates by  $\Delta L$  (b) Shearing stress on a cylinder deforming it by an angle  $\theta$  (c) A body subjected to shearing stress (d) A solid body under a stress normal to the surface at every point (hydraulic stress). The volumetric strain is  $\Delta V/V$ , but there is no change in shape.

in its volume without any change of its geometrical shape.

The body develops internal restoring forces that are equal and opposite to the forces applied by the fluid (the body restores its original shape and size when taken out from the fluid). The internal restoring force per unit area in this case is known as **hydraulic stress** and in magnitude is equal to the hydraulic pressure (applied force per unit area).

The strain produced by a hydraulic pressure is called **volume strain** and is defined as the ratio of change in volume ( $\Delta V$ ) to the original volume ( $V$ ).

$$\text{Volume strain} = \frac{\Delta V}{V} \quad (8.5)$$

Since the strain is a ratio of change in dimension to the original dimension, it has no units or dimensional formula.

### 8.3 HOOKE'S LAW

Stress and strain take different forms in the situations depicted in the Fig. (8.1). For small deformations the stress and strain are proportional to each other. This is known as Hooke's law.

Thus,

$$\begin{aligned} \text{stress} &\propto \text{strain} \\ \text{stress} &= k \times \text{strain} \end{aligned} \quad (8.6)$$

where  $k$  is the proportionality constant and is known as modulus of elasticity.

Hooke's law is an empirical law and is found to be valid for most materials. However, there are some materials which do not exhibit this linear relationship.

### 8.4 STRESS-STRAIN CURVE

The relation between the stress and the strain for a given material under tensile stress can be found experimentally. In a standard test of tensile properties, a test cylinder or a wire is stretched by an applied force. The fractional change in length (the strain) and the applied force needed to cause the strain are recorded. The applied force is gradually increased in steps and the change in length is noted. A graph is plotted between the stress (which is equal in magnitude to the applied force per unit area) and the strain produced. A typical graph for a metal is shown in Fig. 8.2. Analogous graphs for

compression and shear stress may also be obtained. The stress-strain curves vary from material to material. These curves help us to understand how a given material deforms with increasing loads. From the graph, we can see that in the region between O to A, the curve is linear. In this region, Hooke's law is obeyed. The body regains its original dimensions when the applied force is removed. In this region, the solid behaves as an elastic body.

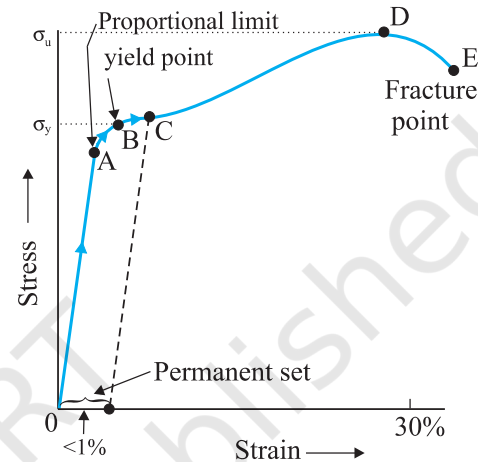

**Fig. 8.2** A typical stress-strain curve for a metal.

In the region from A to B, stress and strain are not proportional. Nevertheless, the body still returns to its original dimension when the load is removed. The point B in the curve is known as **yield point** (also known as **elastic limit**) and the corresponding stress is known as **yield strength** ( $\sigma_y$ ) of the material.

If the load is increased further, the stress developed exceeds the yield strength and strain increases rapidly even for a small change in the stress. The portion of the curve between B and D shows this. When the load is removed, say at some point C between B and D, the body does not regain its original dimension. In this case, even when the stress is zero, the strain is not zero. The material is said to have a **permanent set**. The deformation is said to be **plastic deformation**. The point D on the graph is the **ultimate tensile strength** ( $\sigma_u$ ) of the material. Beyond this point, additional strain is produced even by a reduced applied force and fracture occurs at point E. If the ultimate strength and fracture points D and E are close, the material is said to be **brittle**. If they are far apart, the material is said to be **ductile**.

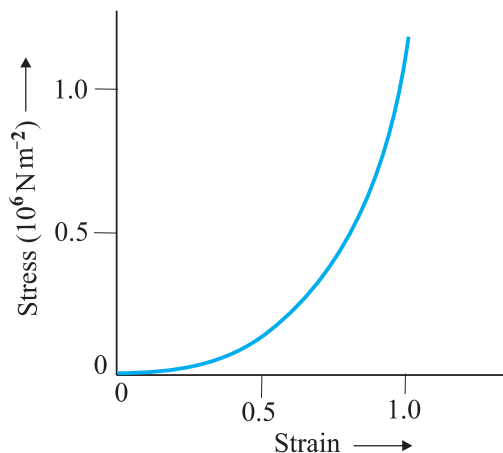

**Fig. 8.3** Stress-strain curve for the elastic tissue of Aorta, the large tube (vessel) carrying blood from the heart.

As stated earlier, the stress-strain behaviour varies from material to material. For example, rubber can be pulled to several times its original length and still returns to its original shape. Fig. 8.3 shows stress-strain curve for the elastic tissue of aorta, present in the heart. Note that although elastic region is very large, the material does not obey Hooke's law over most of the region. Secondly, there is no well defined plastic region. Substances like tissue of aorta, rubber etc. which can be stretched to cause large strains are called **elastomers**.

## 8.5 ELASTIC MODULI

The proportional region within the elastic limit of the stress-strain curve (region OA in Fig. 8.2) is of great importance for structural and manufacturing engineering designs. The ratio of stress and strain, called **modulus of elasticity**, is found to be a characteristic of the material.

### 8.5.1 Young's Modulus

Experimental observation show that for a given material, the magnitude of the strain produced is same whether the stress is tensile or compressive. The ratio of tensile (or compressive) stress ( $\sigma$ ) to the longitudinal strain ( $\epsilon$ ) is defined as **Young's modulus** and is denoted by the symbol  $Y$ .

$$Y = \frac{\sigma}{\epsilon} \quad (8.7)$$

From Eqs. (8.1) and (8.2), we have

$$\begin{aligned} Y &= (F/A)/(\Delta L/L) \\ &= (F \times L)/(A \times \Delta L) \end{aligned} \quad (8.8)$$

Since strain is a dimensionless quantity, the unit of Young's modulus is the same as that of stress *i.e.*,  $\text{N m}^{-2}$  or Pascal (Pa). Table 8.1 gives the values of Young's moduli and yield strengths of some material.

From the data given in Table 8.1, it is noticed that for metals Young's moduli are large.

**Table 8.1 Young's moduli and yield strengths of some material**

Substance	Density $\rho$ ( $\text{kg m}^{-3}$ )	Young's modulus $Y$ ( $10^9 \text{N m}^{-2}$ )	Ultimate strength, $\sigma_u$ ( $10^6 \text{N m}^{-2}$ )	Yield strength $\sigma_y$ ( $10^6 \text{N m}^{-2}$ )
Aluminium	2710	70	110	95
Copper	8890	110	400	200
Iron (wrought)	7800-7900	190	330	170
Steel	7860	200	400	250
Glass <sup>#</sup>	2190	65	50	—
Concrete	2320	30	40	—
Wood <sup>#</sup>	525	13	50	—
Bone <sup>#</sup>	1900	9.4	170	—
Polystyrene	1050	3	48	—

<sup>#</sup> Substance tested under compression

Therefore, these materials require a large force to produce small change in length. To increase the length of a thin steel wire of  $0.1 \text{ cm}^2$  cross-sectional area by 0.1%, a force of 2000 N is required. The force required to produce the same strain in aluminium, brass and copper wires having the same cross-sectional area are 690 N, 900 N and 1100 N respectively. It means that steel is more elastic than copper, brass and aluminium. It is for this reason that steel is preferred in heavy-duty machines and in structural designs. Wood, bone, concrete and glass have rather small Young's moduli.

► **Example 8.1** A structural steel rod has a radius of 10 mm and a length of 1.0 m. A 100 kN force stretches it along its length. Calculate (a) stress, (b) elongation, and (c) strain on the rod. Young's modulus, of structural steel is  $2.0 \times 10^{11} \text{ N m}^{-2}$ .

**Answer** We assume that the rod is held by a clamp at one end, and the force  $F$  is applied at the other end, parallel to the length of the rod. Then the stress on the rod is given by

$$\begin{aligned} \text{Stress} &= \frac{F}{A} = \frac{F}{\pi r^2} \\ &= \frac{100 \times 10^3 \text{ N}}{3.14 \times (10^{-2} \text{ m})^2} \\ &= 3.18 \times 10^8 \text{ N m}^{-2} \end{aligned}$$

The elongation,

$$\begin{aligned} \Delta L &= \frac{(F/A)L}{Y} \\ &= \frac{(3.18 \times 10^8 \text{ N m}^{-2})(1\text{m})}{2 \times 10^{11} \text{ N m}^{-2}} \\ &= 1.59 \times 10^{-3} \text{ m} \\ &= 1.59 \text{ mm} \end{aligned}$$

The strain is given by

$$\begin{aligned} \text{Strain} &= \Delta L/L \\ &= (1.59 \times 10^{-3} \text{ m})/(1\text{m}) \\ &= 1.59 \times 10^{-3} \\ &= 0.16 \% \end{aligned}$$

► **Example 8.2** A copper wire of length 2.2 m and a steel wire of length 1.6 m, both of diameter 3.0 mm, are connected end to end. When stretched by a load, the net elongation is found to be 0.70 mm. Obtain the load applied.

**Answer** The copper and steel wires are under a tensile stress because they have the same tension (equal to the load  $W$ ) and the same area of cross-section  $A$ . From Eq. (8.7) we have stress = strain  $\times$  Young's modulus. Therefore

$$W/A = Y_c \times (\Delta L_c/L_c) = Y_s \times (\Delta L_s/L_s)$$

where the subscripts  $c$  and  $s$  refer to copper and stainless steel respectively. Or,

$$\Delta L_c/\Delta L_s = (Y_s/Y_c) \times (L_c/L_s)$$

$$\text{Given } L_c = 2.2 \text{ m, } L_s = 1.6 \text{ m,}$$

$$\text{From Table 9.1 } Y_c = 1.1 \times 10^{11} \text{ N.m}^{-2}, \text{ and}$$

$$Y_s = 2.0 \times 10^{11} \text{ N.m}^{-2}.$$

$$\Delta L_c/\Delta L_s = (2.0 \times 10^{11}/1.1 \times 10^{11}) \times (2.2/1.6) = 2.5.$$

The total elongation is given to be

$$\Delta L_c + \Delta L_s = 7.0 \times 10^{-4} \text{ m}$$

Solving the above equations,

$$\Delta L_c = 5.0 \times 10^{-4} \text{ m, and } \Delta L_s = 2.0 \times 10^{-4} \text{ m.}$$

Therefore

$$\begin{aligned} W &= (A \times Y_c \times \Delta L_c)/L_c \\ &= \pi (1.5 \times 10^{-3})^2 \times [(5.0 \times 10^{-4} \times 1.1 \times 10^{11})/2.2] \\ &= 1.8 \times 10^2 \text{ N} \end{aligned}$$

► **Example 8.3** In a human pyramid in a circus, the entire weight of the balanced group is supported by the legs of a performer who is lying on his back (as shown in Fig. 8.4). The combined mass of all the persons performing the act, and the tables, plaques etc. involved is 280 kg. The mass of the performer lying on his back at the bottom of the pyramid is 60 kg. Each thighbone (femur) of this performer has a length of 50 cm and an effective radius of 2.0 cm. Determine the amount by which each thighbone gets compressed under the extra load.

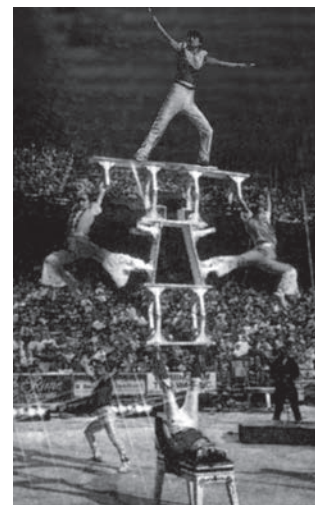

**Fig. 8.4** Human pyramid in a circus.

**Answer** Total mass of all the performers, tables, plaques etc. = 280 kg

Mass of the performer = 60 kg

Mass supported by the legs of the performer at the bottom of the pyramid

= 280 – 60 = 220 kg

Weight of this supported mass

= 220 kg wt. = 220 × 9.8 N = 2156 N.

Weight supported by each thighbone of the performer =  $\frac{1}{2}$  (2156) N = 1078 N.

From Table 9.1, the Young's modulus for bone is given by

$Y = 9.4 \times 10^9 \text{ N m}^{-2}$ .

Length of each thighbone  $L = 0.5 \text{ m}$

the radius of thighbone = 2.0 cm

Thus the cross-sectional area of the thighbone

$A = \pi \times (2 \times 10^{-2})^2 \text{ m}^2 = 1.26 \times 10^{-3} \text{ m}^2$ .

Using Eq. (9.8), the compression in each thighbone ( $\Delta L$ ) can be computed as

$$\begin{aligned} \Delta L &= [(F \times L)/(Y \times A)] \\ &= [(1078 \times 0.5)/(9.4 \times 10^9 \times 1.26 \times 10^{-3})] \\ &= 4.55 \times 10^{-5} \text{ m or } 4.55 \times 10^{-3} \text{ cm.} \end{aligned}$$

This is a very small change! The fractional decrease in the thighbone is  $\Delta L/L = 0.000091$  or 0.0091%. ◀

### 8.5.2 Shear Modulus

The ratio of shearing stress to the corresponding shearing strain is called the *shear modulus* of the material and is represented by  $G$ . It is also called the *modulus of rigidity*.

$G = \text{shearing stress } (\sigma_s) / \text{shearing strain}$

$$\begin{aligned} G &= (F/A)/(\Delta x/L) \\ &= (F \times L)/(A \times \Delta x) \end{aligned} \quad (8.10)$$

Similarly, from Eq. (9.4)

$$\begin{aligned} G &= (F/A)/\theta \\ &= F/(A \times \theta) \end{aligned} \quad (8.11)$$

The shearing stress  $\sigma_s$  can also be expressed as

$$\sigma_s = G \times \theta \quad (8.12)$$

SI unit of shear modulus is  $\text{N m}^{-2}$  or Pa. The shear moduli of a few common materials are given in Table 9.2. It can be seen that shear modulus (or modulus of rigidity) is generally less than Young's modulus (from Table 9.1). For most materials  $G \approx Y/3$ .

**Table 8.2** Shear moduli ( $G$ ) of some common materials

Material	$G$ ( $10^9 \text{ Nm}^{-2}$ or GPa)
Aluminium	25
Brass	36
Copper	42
Glass	23
Iron	70
Lead	5.6
Nickel	77
Steel	84
Tungsten	150
Wood	10

**Example 8.4** A square lead slab of side 50 cm and thickness 10 cm is subject to a shearing force (on its narrow face) of  $9.0 \times 10^4 \text{ N}$ . The lower edge is riveted to the floor. How much will the upper edge be displaced?

**Answer** The lead slab is fixed and the force is applied parallel to the narrow face as shown in Fig. 8.6. The area of the face parallel to which this force is applied is

$$\begin{aligned} A &= 50 \text{ cm} \times 10 \text{ cm} \\ &= 0.5 \text{ m} \times 0.1 \text{ m} \\ &= 0.05 \text{ m}^2 \end{aligned}$$

$$\begin{aligned} \text{Therefore, the stress applied is} \\ &= (9.4 \times 10^4 \text{ N}/0.05 \text{ m}^2) \\ &= 1.80 \times 10^6 \text{ N.m}^{-2} \end{aligned}$$

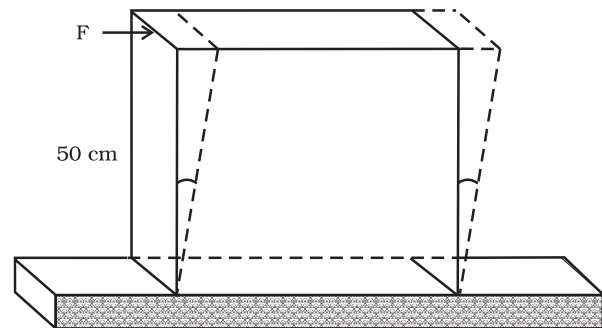

**Fig. 8.5**

We know that shearing strain =  $(\Delta x/L) = \text{Stress} / G$ . Therefore the displacement  $\Delta x = (\text{Stress} \times L)/G = (1.8 \times 10^6 \text{ N m}^{-2} \times 0.5 \text{ m}) / (5.6 \times 10^9 \text{ N m}^{-2}) = 1.6 \times 10^{-4} \text{ m} = 0.16 \text{ mm}$  ◀

### 8.5.3 Bulk Modulus

In Section (8.3), we have seen that when a body is submerged in a fluid, it undergoes a hydraulic stress (equal in magnitude to the hydraulic pressure). This leads to the decrease in the volume of the body thus producing a strain called volume strain [Eq. (8.5)]. The ratio of hydraulic stress to the corresponding hydraulic strain is called *bulk modulus*. It is denoted by symbol  $B$ .

$$B = -p/(\Delta V/V) \quad (8.12)$$

The negative sign indicates the fact that with an increase in pressure, a decrease in volume occurs. That is, if  $p$  is positive,  $\Delta V$  is negative. Thus for a system in equilibrium, the value of bulk modulus  $B$  is always positive. SI unit of bulk modulus is the same as that of pressure *i.e.*,  $\text{N m}^{-2}$  or Pa. The bulk moduli of a few common materials are given in Table 8.3.

The reciprocal of the bulk modulus is called *compressibility* and is denoted by  $k$ . It is defined as the fractional change in volume per unit increase in pressure.

$$k = (1/B) = -(1/\Delta p) \times (\Delta V/V) \quad (8.13)$$

It can be seen from the data given in Table 8.3 that the bulk moduli for solids are much larger than for liquids, which are again much larger than the bulk modulus for gases (air).

**Table 8.3 Bulk moduli ( $B$ ) of some common Materials**

Material Solids	$B$ ( $10^9 \text{ N m}^{-2}$ or GPa)
Aluminium	72
Brass	61
Copper	140
Glass	37
Iron	100
Nickel	260
Steel	160
<b>Liquids</b>	
Water	2.2
Ethanol	0.9
Carbon disulphide	1.56
Glycerine	4.76
Mercury	25
<b>Gases</b>	
Air (at STP)	$1.0 \times 10^{-4}$

**Table 8.4 Stress, strain and various elastic moduli**

Type of stress	Stress	Strain	Change in		Elastic Modulus	Name of Modulus	State of Matter
			shape	volume			
Tensile or compressive ( $\sigma = F/A$ )	Two equal and opposite forces perpendicular to opposite faces	Elongation or compression parallel to force direction ( $\Delta L/L$ ) (longitudinal strain)	Yes	No	$Y = (FL)/(A \Delta L)$	Young's modulus	Solid
Shearing ( $\sigma_s = F/A$ )	Two equal and opposite forces parallel to opposite surfaces forces in each case such that total force and total torque on the body vanishes	Pure shear, $\theta$	Yes	No	$G = F/(A \theta)$	Shear modulus or modulus of rigidity	Solid
Hydraulic	Forces perpendicular everywhere to the surface, force per unit area (pressure) same everywhere.	Volume change (compression or elongation) ( $\Delta V/V$ )	No	Yes	$B = -p/(\Delta V/V)$	Bulk modulus	Solid, liquid and gas

Thus, solids are the least compressible, whereas, gases are the most compressible. Gases are about a million times more compressible than solids! Gases have large compressibilities, which vary with pressure and temperature. The incompressibility of the solids is primarily due to the tight coupling between the neighbouring atoms. The molecules in liquids are also bound with their neighbours but not as strong as in solids. Molecules in gases are very poorly coupled to their neighbours.

Table 8.4 shows the various types of stress, strain, elastic moduli, and the applicable state of matter at a glance.

**Example 8.5** The average depth of Indian Ocean is about 3000 m. Calculate the fractional compression,  $\Delta V/V$ , of water at the bottom of the ocean, given that the bulk modulus of water is  $2.2 \times 10^9 \text{ N m}^{-2}$ . (Take  $g = 10 \text{ m s}^{-2}$ )

**Answer** The pressure exerted by a 3000 m column of water on the bottom layer

$$\begin{aligned} p &= h\rho g = 3000 \text{ m} \times 1000 \text{ kg m}^{-3} \times 10 \text{ m s}^{-2} \\ &= 3 \times 10^7 \text{ kg m}^{-1} \text{ s}^{-2} \\ &= 3 \times 10^7 \text{ N m}^{-2} \end{aligned}$$

Fractional compression  $\Delta V/V$ , is

$$\begin{aligned} \Delta V/V &= \text{stress}/B = (3 \times 10^7 \text{ N m}^{-2}) / (2.2 \times 10^9 \text{ N m}^{-2}) \\ &= 1.36 \times 10^{-2} \text{ or } 1.36 \% \end{aligned}$$

### 8.5.4 POISSON'S RATIO

The strain perpendicular to the applied force is called **lateral strain**. Simon Poisson pointed out that within the elastic limit, lateral strain is directly proportional to the longitudinal strain. The ratio of the lateral strain to the longitudinal strain in a stretched wire is called **Poisson's ratio**. If the original diameter of the wire is  $d$  and the contraction of the diameter under stress is  $\Delta d$ , the lateral strain is  $\Delta d/d$ . If the original length of the wire is  $L$  and the elongation under stress is  $\Delta L$ , the longitudinal strain is  $\Delta L/L$ . Poisson's ratio is then  $(\Delta d/d)/(\Delta L/L)$  or  $(\Delta d/\Delta L)(L/d)$ . Poisson's ratio is a ratio of two strains; it is a pure number and has no dimensions or units. Its value depends only on the nature of material. For steels the value is between 0.28 and 0.30, and for aluminium alloys it is about 0.33.

### 8.5.5 Elastic Potential Energy in a Stretched Wire

When a wire is put under a tensile stress, work is done against the inter-atomic forces. This work is stored in the wire in the form of elastic potential energy. When a wire of original length  $L$  and area of cross-section  $A$  is subjected to a deforming force  $F$  along the length of the wire, let the length of the wire be elongated by  $l$ . Then from Eq. (8.8), we have  $F = YA \times (l/L)$ . Here  $Y$  is the Young's modulus of the material of the wire. Now for a further elongation of infinitesimal small length  $dl$ , work done  $dW$  is  $F dl$  or  $YAl dl/L$ . Therefore, the amount of work done ( $W$ ) in increasing the length of the wire from  $L$  to  $L + l$ , that is from  $l = 0$  to  $l = l$  is

$$\begin{aligned} W &= \int_0^l \frac{YAl}{L} dl = \frac{YA}{L} \times \frac{l^2}{2} \\ W &= \frac{1}{2} \times Y \times \left(\frac{l}{L}\right)^2 \times AL \\ &= \frac{1}{2} \times \text{Young's modulus} \times \text{strain}^2 \times \\ &\quad \text{volume of the wire} \\ &= \frac{1}{2} \times \text{stress} \times \text{strain} \times \text{volume of the} \\ &\quad \text{wire} \end{aligned}$$

This work is stored in the wire in the form of elastic potential energy ( $U$ ). Therefore the elastic potential energy per unit volume of the wire ( $u$ ) is

$$u = \frac{1}{2} \sigma \varepsilon \quad (8.14)$$

### 8.6 APPLICATIONS OF ELASTIC BEHAVIOUR OF MATERIALS

The elastic behaviour of materials plays an important role in everyday life. All engineering designs require precise knowledge of the elastic behaviour of materials. For example while designing a building, the structural design of the columns, beams and supports require knowledge of strength of materials used. Have you ever thought why the beams used in construction of bridges, as supports etc. have a cross-section of the type I? Why does a heap of sand or a hill have a pyramidal shape? Answers to these questions can be obtained from the study of structural engineering which is based on concepts developed here.

Cranes used for lifting and moving heavy loads from one place to another have a thick metal rope to which the load is attached. The rope is pulled up using pulleys and motors. Suppose we want to make a crane, which has a lifting capacity of 10 tonnes or metric tons (1 metric ton = 1000 kg). How thick should the steel rope be? We obviously want that the load does not deform the rope permanently. Therefore, the extension should not exceed the elastic limit. From Table 8.1, we find that mild steel has a yield strength ( $\sigma_y$ ) of about  $300 \times 10^6 \text{ N m}^{-2}$ . Thus, the area of cross-section ( $A$ ) of the rope should at least be

$$\begin{aligned} A &\geq W/\sigma_y = Mg/\sigma_y & (8.15) \\ &= (10^4 \text{ kg} \times 9.8 \text{ m s}^{-2})/(300 \times 10^6 \text{ N m}^{-2}) \\ &= 3.3 \times 10^{-4} \text{ m}^2 \end{aligned}$$

corresponding to a radius of about 1 cm for a rope of circular cross-section. Generally a large margin of safety (of about a factor of ten in the load) is provided. Thus a thicker rope of radius about 3 cm is recommended. A single wire of this radius would practically be a rigid rod. So the ropes are always made of a number of thin wires braided together, like in pigtails, for ease in manufacture, flexibility and strength.

A bridge has to be designed such that it can withstand the load of the flowing traffic, the force of winds and its own weight. Similarly, in the design of buildings the use of beams and columns is very common. In both the cases, the overcoming of the problem of bending of beam under a load is of prime importance. The beam should not bend too much or break. Let us consider the case of a beam loaded at the centre and supported near its ends as shown in Fig. 8.6. A bar of length  $l$ , breadth  $b$ , and depth  $d$  when loaded at the centre by a load  $W$  sags by an amount given by

$$\delta = Wl^3/(4bd^3Y) \quad (8.16)$$

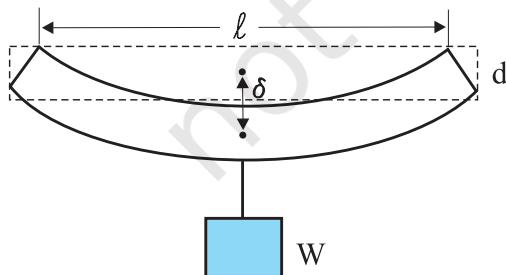

**Fig. 8.6** A beam supported at the ends and loaded at the centre.

This relation can be derived using what you have already learnt and a little calculus. From Eq. (8.16), we see that to reduce the bending for a given load, one should use a material with a large Young's modulus  $Y$ . For a given material, increasing the depth  $d$  rather than the breadth  $b$  is more effective in reducing the bending, since  $\delta$  is proportional to  $d^{-3}$  and only to  $b^{-1}$  (of course the length  $l$  of the span should be as small as possible). But on increasing the depth, unless the load is exactly at the right place (difficult to arrange in a bridge with moving traffic), the deep bar may bend as shown in Fig. 8.7(b). This is called buckling. To avoid this, a common compromise is the cross-sectional shape shown in Fig. 8.7(c). This section provides a large load-bearing surface and enough depth to prevent bending. This shape reduces the weight of the beam without sacrificing the strength and hence reduces the cost.

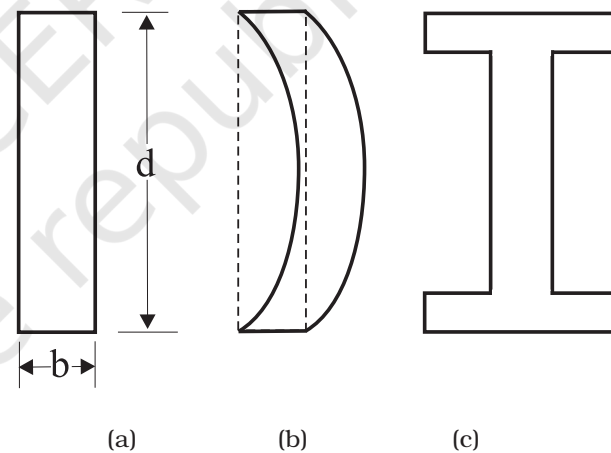

**Fig. 8.7** Different cross-sectional shapes of a beam. (a) Rectangular section of a bar; (b) A thin bar and how it can buckle; (c) Commonly used section for a load bearing bar.

The use of pillars or columns is also very common in buildings and bridges. A pillar with rounded ends as shown in Fig. 8.9(a) supports less load than that with a distributed shape at the ends [Fig. 8.9(b)]. The precise design of a bridge or a building has to take into account the conditions under which it will function, the cost and long period, reliability of usable material, etc.



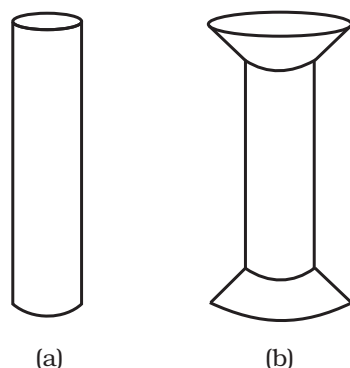

**Fig. 8.8** Pillars or columns: (a) a pillar with rounded ends, (b) Pillar with distributed ends.

The answer to the question why the maximum height of a mountain on earth is  $\sim 10$  km can also be provided by considering the elastic properties of rocks. A mountain base is not under uniform compression and this provides some

shearing stress to the rocks under which they can flow. The stress due to all the material on the top should be less than the critical shearing stress at which the rocks flow.

At the bottom of a mountain of height  $h$ , the force per unit area due to the weight of the mountain is  $h\rho g$  where  $\rho$  is the density of the material of the mountain and  $g$  is the acceleration due to gravity. The material at the bottom experiences this force in the vertical direction, and the sides of the mountain are free. Therefore, this is not a case of pressure or bulk compression. There is a shear component, approximately  $h\rho g$  itself. Now the elastic limit for a typical rock is  $30 \times 10^7 \text{ N m}^{-2}$ . Equating this to  $h\rho g$ , with  $\rho = 3 \times 10^3 \text{ kg m}^{-3}$  gives

$$h\rho g = 30 \times 10^7 \text{ N m}^{-2}.$$

$$h = 30 \times 10^7 \text{ N m}^{-2} / (3 \times 10^3 \text{ kg m}^{-3} \times 10 \text{ m s}^{-2}) = 10 \text{ km}$$

which is more than the height of Mt. Everest!

#### SUMMARY

1. Stress is the restoring force per unit area and strain is the fractional change in dimension. In general there are three types of stresses (a) tensile stress — longitudinal stress (associated with stretching) or compressive stress (associated with compression), (b) shearing stress, and (c) hydraulic stress.

2. For small deformations, stress is directly proportional to the strain for many materials. This is known as Hooke's law. The constant of proportionality is called modulus of elasticity. Three elastic moduli *viz.*, Young's modulus, shear modulus and bulk modulus are used to describe the elastic behaviour of objects as they respond to deforming forces that act on them.

A class of solids called elastomers does not obey Hooke's law.

3. When an object is under tension or compression, the Hooke's law takes the form

$$F/A = Y\Delta L/L$$

where  $\Delta L/L$  is the tensile or compressive strain of the object,  $F$  is the magnitude of the applied force causing the strain,  $A$  is the cross-sectional area over which  $F$  is applied (perpendicular to  $A$ ) and  $Y$  is the Young's modulus for the object. The stress is  $F/A$ .

4. A pair of forces when applied parallel to the upper and lower faces, the solid deforms so that the upper face moves sideways with respect to the lower. The horizontal displacement  $\Delta L$  of the upper face is perpendicular to the vertical height  $L$ . This type of deformation is called shear and the corresponding stress is the shearing stress. This type of stress is possible only in solids.

In this kind of deformation the Hooke's law takes the form

$$F/A = G \times \Delta L/L$$

where  $\Delta L$  is the displacement of one end of object in the direction of the applied force  $F$ , and  $G$  is the shear modulus.

5. When an object undergoes hydraulic compression due to a stress exerted by a surrounding fluid, the Hooke's law takes the form

$$p = B(\Delta V/V),$$

where  $p$  is the pressure (hydraulic stress) on the object due to the fluid,  $\Delta V/V$  (the volume strain) is the absolute fractional change in the object's volume due to that pressure and  $B$  is the bulk modulus of the object.

**POINTS TO PONDER**

1. In the case of a wire, suspended from ceiling and stretched under the action of a weight ( $F$ ) suspended from its other end, the force exerted by the ceiling on it is equal and opposite to the weight. However, the tension at any cross-section  $A$  of the wire is just  $F$  and not  $2F$ . Hence, tensile stress which is equal to the tension per unit area is equal to  $F/A$ .
2. Hooke's law is valid only in the linear part of stress-strain curve.
3. The Young's modulus and shear modulus are relevant only for solids since only solids have lengths and shapes.
4. Bulk modulus is relevant for solids, liquid and gases. It refers to the change in volume when every part of the body is under the uniform stress so that the shape of the body remains unchanged.
5. Metals have larger values of Young's modulus than alloys and elastomers. A material with large value of Young's modulus requires a large force to produce small changes in its length.
6. In daily life, we feel that a material which stretches more is more elastic, but it is a misnomer. In fact material which stretches to a lesser extent for a given load is considered to be more elastic.
7. In general, a deforming force in one direction can produce strains in other directions also. The proportionality between stress and strain in such situations cannot be described by just one elastic constant. For example, for a wire under longitudinal strain, the lateral dimensions (radius of cross section) will undergo a small change, which is described by another elastic constant of the material (called *Poisson ratio*).
8. Stress is not a vector quantity since, unlike a force, the stress cannot be assigned a specific direction. Force acting on the portion of a body on a specified side of a section has a definite direction.

**EXERCISES**

- 8.1 A steel wire of length 4.7 m and cross-sectional area  $3.0 \times 10^{-5} \text{ m}^2$  stretches by the same amount as a copper wire of length 3.5 m and cross-sectional area of  $4.0 \times 10^{-5} \text{ m}^2$  under a given load. What is the ratio of the Young's modulus of steel to that of copper?
- 8.2 Figure 8.9 shows the strain-stress curve for a given material. What are (a) Young's modulus and (b) approximate yield strength for this material?

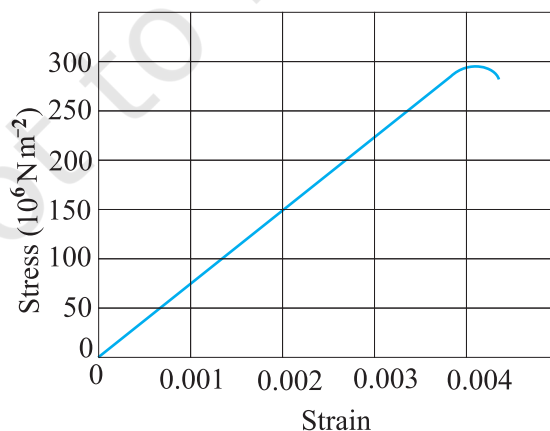
**Fig. 8.9**

- 8.3** The stress-strain graphs for materials *A* and *B* are shown in Fig. 8.10.

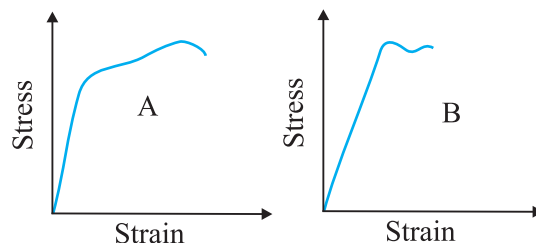

**Fig. 8.10**

The graphs are drawn to the same scale.

- (a) Which of the materials has the greater Young's modulus?  
 (b) Which of the two is the stronger material?
- 8.4** Read the following two statements below carefully and state, with reasons, if it is true or false.  
 (a) The Young's modulus of rubber is greater than that of steel;  
 (b) The stretching of a coil is determined by its shear modulus.
- 8.5** Two wires of diameter 0.25 cm, one made of steel and the other made of brass are loaded as shown in Fig. 8.11. The unloaded length of steel wire is 1.5 m and that of brass wire is 1.0 m. Compute the elongations of the steel and the brass wires.

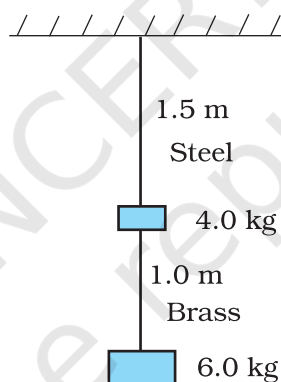

**Fig. 8.11**

- 8.6** The edge of an aluminium cube is 10 cm long. One face of the cube is firmly fixed to a vertical wall. A mass of 100 kg is then attached to the opposite face of the cube. The shear modulus of aluminium is 25 GPa. What is the vertical deflection of this face?
- 8.7** Four identical hollow cylindrical columns of mild steel support a big structure of mass 50,000 kg. The inner and outer radii of each column are 30 and 60 cm respectively. Assuming the load distribution to be uniform, calculate the compressional strain of each column.
- 8.8** A piece of copper having a rectangular cross-section of 15.2 mm  $\times$  19.1 mm is pulled in tension with 44,500 N force, producing only elastic deformation. Calculate the resulting strain?
- 8.9** A steel cable with a radius of 1.5 cm supports a chairlift at a ski area. If the maximum stress is not to exceed  $10^8 \text{ N m}^{-2}$ , what is the maximum load the cable can support?
- 8.10** A rigid bar of mass 15 kg is supported symmetrically by three wires each 2.0 m long. Those at each end are of copper and the middle one is of iron. Determine the ratios of their diameters if each is to have the same tension.
- 8.11** A 14.5 kg mass, fastened to the end of a steel wire of unstretched length 1.0 m, is whirled in a vertical circle with an angular velocity of 2 rev/s at the bottom of the circle. The cross-sectional area of the wire is  $0.065 \text{ cm}^2$ . Calculate the elongation of the wire when the mass is at the lowest point of its path.

- 8.12** Compute the bulk modulus of water from the following data: Initial volume = 100.0 litre, Pressure increase = 100.0 atm (1 atm =  $1.013 \times 10^5$  Pa), Final volume = 100.5 litre. Compare the bulk modulus of water with that of air (at constant temperature). Explain in simple terms why the ratio is so large.
- 8.13** What is the density of water at a depth where pressure is 80.0 atm, given that its density at the surface is  $1.03 \times 10^3$  kg m<sup>-3</sup>?
- 8.14** Compute the fractional change in volume of a glass slab, when subjected to a hydraulic pressure of 10 atm.
- 8.15** Determine the volume contraction of a solid copper cube, 10 cm on an edge, when subjected to a hydraulic pressure of  $7.0 \times 10^6$  Pa.
- 8.16** How much should the pressure on a litre of water be changed to compress it by 0.10%? carry one quarter of the load.

© NCERT  
not to be republished



11087CH10

## CHAPTER NINE

# MECHANICAL PROPERTIES OF FLUIDS

- 9.1 Introduction
- 9.2 Pressure
- 9.3 Streamline flow
- 9.4 Bernoulli's principle
- 9.5 Viscosity
- 9.6 Surface tension
- Summary
- Points to ponder
- Exercises
- Additional exercises
- Appendix

### 9.1 INTRODUCTION

In this chapter, we shall study some common physical properties of liquids and gases. Liquids and gases can flow and are therefore, called fluids. It is this property that distinguishes liquids and gases from solids in a basic way.

Fluids are everywhere around us. Earth has an envelop of air and two-thirds of its surface is covered with water. Water is not only necessary for our existence; every mammalian body constitute mostly of water. All the processes occurring in living beings including plants are mediated by fluids. Thus understanding the behaviour and properties of fluids is important.

How are fluids different from solids? What is common in liquids and gases? Unlike a solid, a fluid has no definite shape of its own. Solids and liquids have a fixed volume, whereas a gas fills the entire volume of its container. We have learnt in the previous chapter that the volume of solids can be changed by stress. The volume of solid, liquid or gas depends on the stress or pressure acting on it. When we talk about fixed volume of solid or liquid, we mean its volume under atmospheric pressure. The difference between gases and solids or liquids is that for solids or liquids the change in volume due to change of external pressure is rather small. In other words solids and liquids have much lower compressibility as compared to gases.

Shear stress can change the shape of a solid keeping its volume fixed. The key property of fluids is that they offer very little resistance to shear stress; their shape changes by application of very small shear stress. The shearing stress of fluids is about million times smaller than that of solids.

### 9.2 PRESSURE

A sharp needle when pressed against our skin pierces it. Our skin, however, remains intact when a blunt object with a wider contact area (say the back of a spoon) is pressed against it with the same force. If an elephant were to step on a man's chest, his ribs would crack. A circus performer across whose

chest a large, light but strong wooden plank is placed first, is saved from this accident. Such everyday experiences convince us that both the force and its coverage area are important. Smaller the area on which the force acts, greater is the impact. This impact is known as pressure.

When an object is submerged in a fluid at rest, the fluid exerts a force on its surface. This force is always normal to the object's surface. This is so because if there were a component of force parallel to the surface, the object will also exert a force on the fluid parallel to it; as a consequence of Newton's third law. This force will cause the fluid to flow parallel to the surface. Since the fluid is at rest, this cannot happen. Hence, the force exerted by the fluid at rest has to be perpendicular to the surface in contact with it. This is shown in Fig. 9.1(a).

The normal force exerted by the fluid at a point may be measured. An idealised form of one such pressure-measuring device is shown in Fig. 9.1(b). It consists of an evacuated chamber with a spring that is calibrated to measure the force acting on the piston. This device is placed at a point inside the fluid. The inward force exerted by the fluid on the piston is balanced by the outward spring force and is thereby measured.

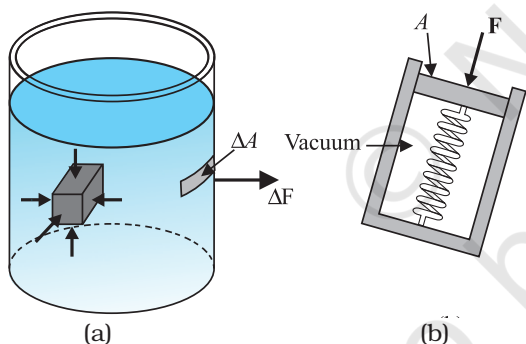

**Fig. 9.1** (a) The force exerted by the liquid in the beaker on the submerged object or on the walls is normal (perpendicular) to the surface at all points.  
(b) An idealised device for measuring pressure.

If  $F$  is the magnitude of this normal force on the piston of area  $A$  then the **average pressure**  $P_{av}$  is defined as the normal force acting per unit area.

$$P_{av} = \frac{F}{A} \quad (9.1)$$

In principle, the piston area can be made arbitrarily small. The pressure is then defined in a limiting sense as

$$P = \lim_{\Delta A \rightarrow 0} \frac{\Delta F}{\Delta A} \quad (9.2)$$

Pressure is a scalar quantity. We remind the reader that it is the component of the force normal to the area under consideration and not the (vector) force that appears in the numerator in Eqs. (9.1) and (9.2). Its dimensions are  $[ML^{-1}T^{-2}]$ . The SI unit of pressure is  $N\ m^{-2}$ . It has been named as pascal (Pa) in honour of the French scientist Blaise Pascal (1623-1662) who carried out pioneering studies on fluid pressure. A common unit of pressure is the atmosphere (atm), i.e. the pressure exerted by the atmosphere at sea level ( $1\ atm = 1.013 \times 10^5\ Pa$ ).

Another quantity, that is indispensable in describing fluids, is the density  $\rho$ . For a fluid of mass  $m$  occupying volume  $V$ ,

$$\rho = \frac{m}{V} \quad (9.3)$$

The dimensions of density are  $[ML^{-3}]$ . Its SI unit is  $kg\ m^{-3}$ . It is a positive scalar quantity. A liquid is largely incompressible and its density is therefore, nearly constant at all pressures. Gases, on the other hand exhibit a large variation in densities with pressure.

The density of water at  $4^\circ C$  (277 K) is  $1.0 \times 10^3\ kg\ m^{-3}$ . The relative density of a substance is the ratio of its density to the density of water at  $4^\circ C$ . It is a dimensionless positive scalar quantity. For example the relative density of aluminium is 2.7. Its density is  $2.7 \times 10^3\ kg\ m^{-3}$ . The densities of some common fluids are displayed in Table 9.1.

**Table 9.1** Densities of some common fluids at STP\*

Fluid	$\rho$ ( $kg\ m^{-3}$ )
Water	$1.00 \times 10^3$
Sea water	$1.03 \times 10^3$
Mercury	$13.6 \times 10^3$
Ethyl alcohol	$0.806 \times 10^3$
Whole blood	$1.06 \times 10^3$
Air	1.29
Oxygen	1.43
Hydrogen	$9.0 \times 10^{-2}$
Interstellar space	$\approx 10^{-20}$

\* STP means standard temperature ( $0^\circ C$ ) and 1 atm pressure.

▶ **Example 9.1** The two thigh bones (femurs), each of cross-sectional area  $10 \text{ cm}^2$  support the upper part of a human body of mass  $40 \text{ kg}$ . Estimate the average pressure sustained by the femurs.

**Answer** Total cross-sectional area of the femurs is  $A = 2 \times 10 \text{ cm}^2 = 20 \times 10^{-4} \text{ m}^2$ . The force acting on them is  $F = 40 \text{ kg wt} = 400 \text{ N}$  (taking  $g = 10 \text{ m s}^{-2}$ ). This force is acting vertically down and hence, normally on the femurs. Thus, the average pressure is

$$P_{av} = \frac{F}{A} = 2 \times 10^5 \text{ N m}^{-2}$$

### 9.2.1 Pascal's Law

The French scientist Blaise Pascal observed that the pressure in a fluid at rest is the same at all points if they are at the same height. This fact may be demonstrated in a simple way.

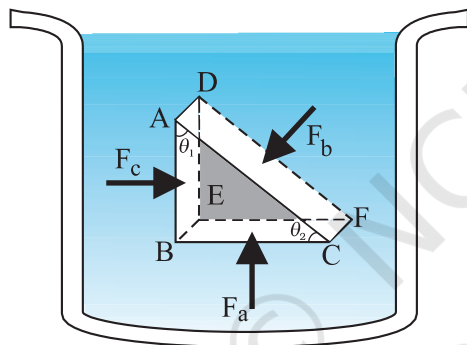

**Fig. 9.2** Proof of Pascal's law. ABC-DEF is an element of the interior of a fluid at rest. This element is in the form of a right-angled prism. The element is small so that the effect of gravity can be ignored, but it has been enlarged for the sake of clarity.

Fig. 9.2 shows an element in the interior of a fluid at rest. This element ABC-DEF is in the form of a right-angled prism. In principle, this prismatic element is very small so that every part of it can be considered at the same depth from the liquid surface and therefore, the effect of the gravity is the same at all these points. But for clarity we have enlarged this element. The forces on this element are those exerted by the rest of the fluid and they must be normal to the surfaces of the element as discussed above. Thus, the fluid exerts pressures  $P_a$ ,  $P_b$  and  $P_c$  on

this element of area corresponding to the normal forces  $F_a$ ,  $F_b$  and  $F_c$  as shown in Fig. 9.2 on the faces BEFC, ADFC and ADEB denoted by  $A_a$ ,  $A_b$  and  $A_c$  respectively. Then

$$F_b \sin \theta = F_c, \quad F_b \cos \theta = F_a \quad (\text{by equilibrium})$$

$$A_b \sin \theta = A_c, \quad A_b \cos \theta = A_a \quad (\text{by geometry})$$

Thus,

$$\frac{F_b}{A_b} = \frac{F_c}{A_c} = \frac{F_a}{A_a}; \quad P_b = P_c = P_a \quad (9.4)$$

Hence, pressure exerted is same in all directions in a fluid at rest. It again reminds us that like other types of stress, pressure is not a vector quantity. No direction can be assigned to it. The force against any area within (or bounding) a fluid at rest and under pressure is normal to the area, regardless of the orientation of the area.

Now consider a fluid element in the form of a horizontal bar of uniform cross-section. The bar is in equilibrium. The horizontal forces exerted at its two ends must be balanced or the pressure at the two ends should be equal. This proves that for a liquid in equilibrium the pressure is same at all points in a horizontal plane. Suppose the pressure were not equal in different parts of the fluid, then there would be a flow as the fluid will have some net force acting on it. Hence in the absence of flow the pressure in the fluid must be same everywhere in a horizontal plane.

### 9.2.2 Variation of Pressure with Depth

Consider a fluid at rest in a container. In Fig. 9.3 point 1 is at height  $h$  above a point 2. The pressures at points 1 and 2 are  $P_1$  and  $P_2$  respectively. Consider a cylindrical element of fluid having area of base  $A$  and height  $h$ . As the fluid is at rest the resultant horizontal forces should be zero and the resultant vertical forces should balance the weight of the element. The forces acting in the vertical direction are due to the fluid pressure at the top ( $P_1 A$ ) acting downward, at the bottom ( $P_2 A$ ) acting upward. If  $mg$  is weight of the fluid in the cylinder we have

$$(P_2 - P_1) A = mg \quad (9.5)$$

Now, if  $\rho$  is the mass density of the fluid, we have the mass of fluid to be  $m = \rho V = \rho h A$  so that

$$P_2 - P_1 = \rho gh \quad (9.6)$$

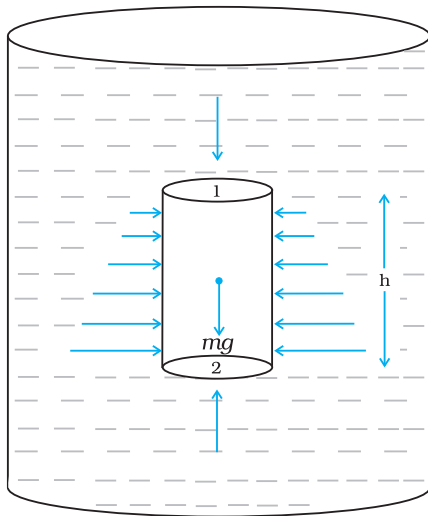

**Fig.9.3** Fluid under gravity. The effect of gravity is illustrated through pressure on a vertical cylindrical column.

Pressure difference depends on the vertical distance  $h$  between the points (1 and 2), mass density of the fluid  $\rho$  and acceleration due to gravity  $g$ . If the point 1 under discussion is shifted to the top of the fluid (say, water), which is open to the atmosphere,  $P_1$  may be replaced by atmospheric pressure ( $P_a$ ) and we replace  $P_2$  by  $P$ . Then Eq. (9.6) gives

$$P = P_a + \rho gh \quad (9.7)$$

Thus, the pressure  $P$ , at depth below the surface of a liquid open to the atmosphere is greater than atmospheric pressure by an amount  $\rho gh$ . The excess of pressure,  $P - P_a$ , at depth  $h$  is called a **gauge pressure** at that point.

The area of the cylinder is not appearing in the expression of absolute pressure in Eq. (9.7). Thus, the height of the fluid column is important and not cross-sectional or base area or the shape of the container. The liquid pressure is the same at all points at the same horizontal level (same depth). The result is appreciated through the example of **hydrostatic paradox**. Consider three vessels A, B and C [Fig.9.4] of different shapes. They are connected at the bottom by a horizontal pipe. On filling with water, the level in the three vessels is the same, though they hold different amounts of water. This is so because water at the bottom has the same pressure below each section of the vessel.

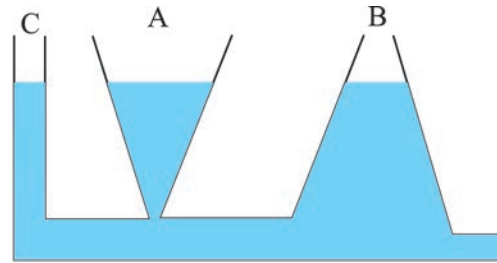

**Fig 9.4** Illustration of hydrostatic paradox. The three vessels A, B and C contain different amounts of liquids, all upto the same height.

**Example 9.2** What is the pressure on a swimmer 10 m below the surface of a lake?

**Answer** Here

$h = 10$  m and  $\rho = 1000$  kg m<sup>-3</sup>. Take  $g = 10$  m s<sup>-2</sup>

From Eq. (9.7)

$$\begin{aligned} P &= P_a + \rho gh \\ &= 1.01 \times 10^5 \text{ Pa} + 1000 \text{ kg m}^{-3} \times 10 \text{ m s}^{-2} \times 10 \text{ m} \\ &= 2.01 \times 10^5 \text{ Pa} \\ &\approx 2 \text{ atm} \end{aligned}$$

This is a 100% increase in pressure from surface level. At a depth of 1 km, the increase in pressure is 100 atm! Submarines are designed to withstand such enormous pressures. ◀

### 9.2.3 Atmospheric Pressure and Gauge Pressure

The pressure of the atmosphere at any point is equal to the weight of a column of air of unit cross-sectional area extending from that point to the top of the atmosphere. At sea level, it is  $1.013 \times 10^5$  Pa (1 atm). Italian scientist Evangelista Torricelli (1608–1647) devised for the first time a method for measuring atmospheric pressure. A long glass tube closed at one end and filled with mercury is inverted into a trough of mercury as shown in Fig.9.5 (a). This device is known as ‘mercury barometer’. The space above the mercury column in the tube contains only mercury vapour whose pressure  $P$  is so small that it may be neglected. Thus, the pressure at Point A=0. The pressure inside the column at Point B must be the same as the pressure at Point C, which is atmospheric pressure,  $P_a$ .

$$P_a = \rho gh \quad (9.8)$$

where  $\rho$  is the density of mercury and  $h$  is the height of the mercury column in the tube.



In the experiment it is found that the mercury column in the barometer has a height of about 76 cm at sea level equivalent to one atmosphere (1 atm). This can also be obtained using the value of  $\rho$  in Eq. (9.8). A common way of stating pressure is in terms of cm or mm of mercury (Hg). A pressure equivalent of 1 mm is called a torr (after Torricelli).

$$1 \text{ torr} = 133 \text{ Pa.}$$

The mm of Hg and torr are used in medicine and physiology. In meteorology, a common unit is the bar and millibar.

$$1 \text{ bar} = 10^5 \text{ Pa}$$

An open tube manometer is a useful instrument for measuring pressure differences. It consists of a U-tube containing a suitable liquid i.e., a low density liquid (such as oil) for measuring small pressure differences and a high density liquid (such as mercury) for large pressure differences. One end of the tube is open to the atmosphere and the other end is connected to the system whose pressure we want to measure [see Fig. 9.5 (b)]. The pressure  $P$  at A is equal to pressure at point B. What we normally measure is the gauge pressure, which is  $P - P_a$ , given by Eq. (9.8) and is proportional to manometer height  $h$ .

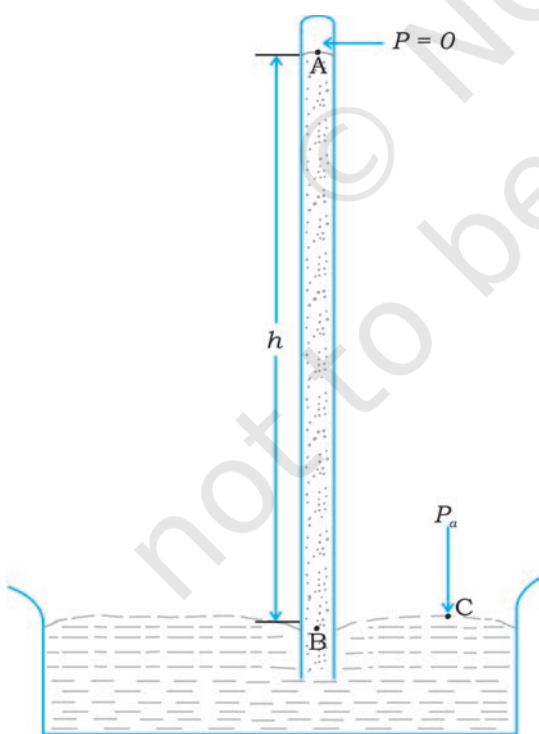
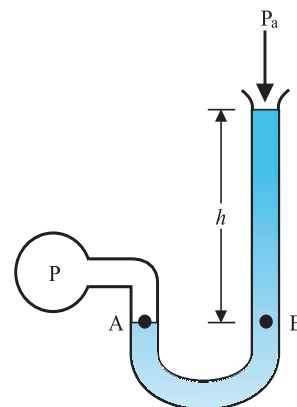

Fig 9.5 (a) The mercury barometer.



(b) The open tube manometer

Fig 9.5 Two pressure measuring devices.

Pressure is same at the same level on both sides of the U-tube containing a fluid. For liquids, the density varies very little over wide ranges in pressure and temperature and we can treat it safely as a constant for our present purposes. Gases on the other hand, exhibits large variations of densities with changes in pressure and temperature. Unlike gases, liquids are, therefore, largely treated as incompressible.

**Example 9.3** The density of the atmosphere at sea level is  $1.29 \text{ kg/m}^3$ . Assume that it does not change with altitude. Then how high would the atmosphere extend?

**Answer** We use Eq. (9.7)

$$\rho gh = 1.29 \text{ kg m}^{-3} \times 9.8 \text{ m s}^{-2} \times h \text{ m} = 1.01 \times 10^5 \text{ Pa}$$

$$\therefore h = 7989 \text{ m} \approx 8 \text{ km}$$

In reality the density of air decreases with height. So does the value of  $g$ . The atmospheric cover extends with decreasing pressure over 100 km. We should also note that the sea level atmospheric pressure is not always 760 mm of Hg. A drop in the Hg level by 10 mm or more is a sign of an approaching storm. ◀

**Example 9.4** At a depth of 1000 m in an ocean (a) what is the absolute pressure? (b) What is the gauge pressure? (c) Find the force acting on the window of area  $20 \text{ cm} \times 20 \text{ cm}$  of a submarine at this depth, the interior of which is maintained at sea-level atmospheric pressure. (The density of sea water is  $1.03 \times 10^3 \text{ kg m}^{-3}$ ,  $g = 10 \text{ m s}^{-2}$ .)

**Answer** Here  $h = 1000 \text{ m}$  and  $\rho = 1.03 \times 10^3 \text{ kg m}^{-3}$ .

- (a) From Eq. (9.6), absolute pressure
- $$P = P_a + \rho gh$$
- $$= 1.01 \times 10^5 \text{ Pa} + 1.03 \times 10^3 \text{ kg m}^{-3} \times 10 \text{ m s}^{-2} \times 1000 \text{ m}$$
- $$= 104.01 \times 10^5 \text{ Pa} \approx 104 \text{ atm}$$
- (b) Gauge pressure is  $P - P_a = \rho gh = P_g$
- $$P_g = 1.03 \times 10^3 \text{ kg m}^{-3} \times 10 \text{ m s}^{-2} \times 1000 \text{ m}$$
- $$= 103 \times 10^5 \text{ Pa} \approx 103 \text{ atm}$$
- (c) The pressure outside the submarine is  $P = P_a + \rho gh$  and the pressure inside it is  $P_a$ . Hence, the net pressure acting on the window is gauge pressure,  $P_g = \rho gh$ . Since the area of the window is  $A = 0.04 \text{ m}^2$ , the force acting on it is
- $$F = P_g A = 103 \times 10^5 \text{ Pa} \times 0.04 \text{ m}^2 = 4.12 \times 10^5 \text{ N}$$

### 9.2.4 Hydraulic Machines

Let us now consider what happens when we change the pressure on a fluid contained in a vessel. Consider a horizontal cylinder with a piston and three vertical tubes at different points [Fig. 9.6 (a)]. The pressure in the horizontal cylinder is indicated by the height of liquid column in the vertical tubes. It is necessarily the same in all. If we push the piston, the fluid level rises in all the tubes, again reaching the same level in each one of them.

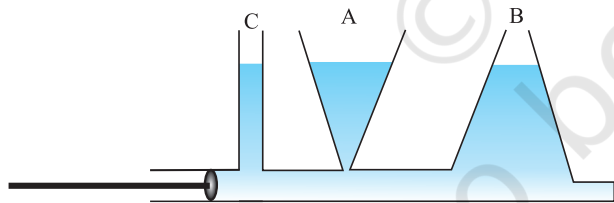

**Fig 9.6 (a)** Whenever external pressure is applied on any part of a fluid in a vessel, it is equally transmitted in all directions.

This indicates that when the pressure on the cylinder was increased, it was distributed uniformly throughout. We can say **whenever external pressure is applied on any part of a fluid contained in a vessel, it is transmitted undiminished and equally in all directions. This is another form of the Pascal's law and it has many applications in daily life.**

A number of devices, such as **hydraulic lift** and **hydraulic brakes**, are based on the Pascal's

law. In these devices, fluids are used for transmitting pressure. In a hydraulic lift, as shown in Fig. 9.6 (b), two pistons are separated by the space filled with a liquid. A piston of small cross-section  $A_1$  is used to exert a force  $F_1$  directly

on the liquid. The pressure  $P = \frac{F_1}{A_1}$  is transmitted throughout the liquid to the larger cylinder attached with a larger piston of area  $A_2$ , which results in an upward force of  $P \times A_2$ . Therefore, the piston is capable of supporting a large force (large weight of, say a car, or a truck,

placed on the platform)  $F_2 = PA_2 = \frac{F_1 A_2}{A_1}$ . By changing the force at  $A_1$ , the platform can be moved up or down. Thus, the applied force has

been increased by a factor of  $\frac{A_2}{A_1}$  and this factor is the mechanical advantage of the device. The example below clarifies it.

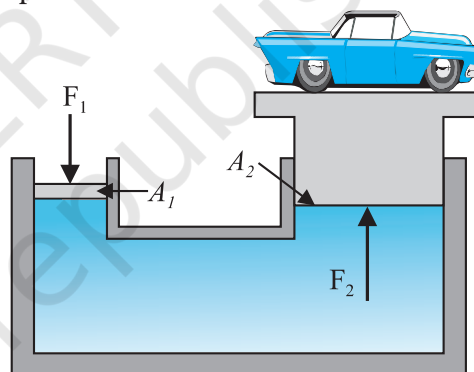

**Fig 9.6 (b)** Schematic diagram illustrating the principle behind the hydraulic lift, a device used to lift heavy loads.

**Example 9.5** Two syringes of different cross-sections (without needles) filled with water are connected with a tightly fitted rubber tube filled with water. Diameters of the smaller piston and larger piston are 1.0 cm and 3.0 cm respectively. (a) Find the force exerted on the larger piston when a force of 10 N is applied to the smaller piston. (b) If the smaller piston is pushed in through 6.0 cm, how much does the larger piston move out?

**Answer** (a) Since pressure is transmitted undiminished throughout the fluid,

$$F_2 = \frac{A_2}{A_1} F_1 = \frac{\pi(3/2 \times 10^{-2} \text{ m})^2}{\pi(1/2 \times 10^{-2} \text{ m})^2} \times 10 \text{ N} \\ = 90 \text{ N}$$

(b) Water is considered to be perfectly incompressible. Volume covered by the movement of smaller piston inwards is equal to volume moved outwards due to the larger piston.

$$L_1 A_1 = L_2 A_2 \\ L_2 = \frac{A_1}{A_2} L_1 = \frac{\pi(1/2 \times 10^{-2} \text{ m})^2}{\pi(3/2 \times 10^{-2} \text{ m})^2} \times 6 \times 10^{-2} \text{ m} \\ \approx 0.67 \times 10^{-2} \text{ m} = 0.67 \text{ cm}$$

Note, atmospheric pressure is common to both pistons and has been ignored. ◀

▶ **Example 9.6** In a car lift compressed air exerts a force  $F_1$  on a small piston having a radius of 5.0 cm. This pressure is transmitted to a second piston of radius 15 cm (Fig 9.7). If the mass of the car to be lifted is 1350 kg, calculate  $F_1$ . What is the pressure necessary to accomplish this task? ( $g = 9.8 \text{ ms}^{-2}$ ).

**Answer** Since pressure is transmitted undiminished throughout the fluid,

$$F_1 = \frac{A_1}{A_2} F_2 = \frac{\pi(5 \times 10^{-2} \text{ m})^2}{\pi(15 \times 10^{-2} \text{ m})^2} (1350 \text{ kg} \times 9.8 \text{ m s}^{-2}) \\ = 1470 \text{ N} \\ \approx 1.5 \times 10^3 \text{ N}$$

The air pressure that will produce this force is

$$P = \frac{F_1}{A_1} = \frac{1.5 \times 10^3 \text{ N}}{\pi(5 \times 10^{-2})^2 \text{ m}^2} = 1.9 \times 10^5 \text{ Pa}$$

This is almost double the atmospheric pressure. ▶

Hydraulic brakes in automobiles also work on the same principle. When we apply a little force on the pedal with our foot the master piston moves inside the master cylinder, and the pressure caused is transmitted through the brake oil to act on a piston of larger area. A large force acts on the piston and is pushed down expanding the brake shoes against brake lining. In this way, a small force on the pedal produces a large retarding force on the wheel. An

important advantage of the system is that the pressure set up by pressing pedal is transmitted equally to all cylinders attached to the four wheels so that the braking effort is equal on all wheels.

### 9.3 STREAMLINE FLOW

**So far we have studied fluids at rest.** The study of the fluids in motion is known as fluid dynamics. When a water tap is turned on slowly, the water flow is smooth initially, but loses its smoothness when the speed of the outflow is increased. In studying the motion of fluids, we focus our attention on what is happening to various fluid particles at a particular point in space at a particular time. The flow of the fluid is said to be **steady** if at any given point, the velocity of each passing fluid particle remains constant in time. This does not mean that the velocity at different points in space is same. The velocity of a particular particle may change as it moves from one point to another. That is, at some other point the particle may have a different velocity, but every other particle which passes the second point behaves exactly as the previous particle that has just passed that point. Each particle follows a smooth path, and the paths of the particles do not cross each other.

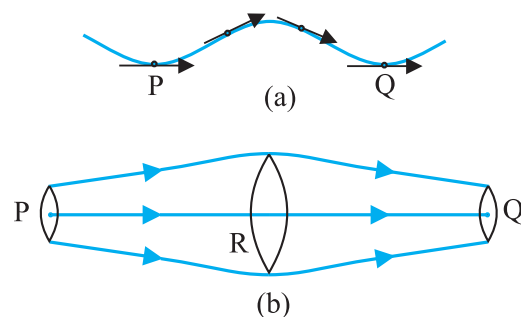

**Fig. 9.7** The meaning of streamlines. (a) A typical trajectory of a fluid particle. (b) A region of streamline flow.

The path taken by a fluid particle under a steady flow is a **streamline**. It is defined as a curve whose tangent at any point is in the direction of the fluid velocity at that point. Consider the path of a particle as shown in Fig.9.7 (a), the curve describes how a fluid particle moves with time. The curve PQ is like a

permanent map of fluid flow, indicating how the fluid streams. No two streamlines can cross, for if they do, an oncoming fluid particle can go either one way or the other and the flow would not be steady. Hence, in steady flow, the map of flow is stationary in time. How do we draw closely spaced streamlines? If we intend to show streamline of every flowing particle, we would end up with a continuum of lines. Consider planes perpendicular to the direction of fluid flow e.g., at three points P, R and Q in Fig.9.7 (b). The plane pieces are so chosen that their boundaries be determined by the same set of streamlines. This means that number of fluid particles crossing the surfaces as indicated at P, R and Q is the same. If area of cross-sections at these points are  $A_P, A_R$  and  $A_Q$  and speeds of fluid particles are  $v_P, v_R$  and  $v_Q$ , then mass of fluid  $\Delta m_P$  crossing at  $A_P$  in a small interval of time  $\Delta t$  is  $\rho_P A_P v_P \Delta t$ . Similarly mass of fluid  $\Delta m_R$  flowing or crossing at  $A_R$  in a small interval of time  $\Delta t$  is  $\rho_R A_R v_R \Delta t$  and mass of fluid  $\Delta m_Q$  is  $\rho_Q A_Q v_Q \Delta t$  crossing at  $A_Q$ . The mass of liquid flowing out equals the mass flowing in, holds in all cases. Therefore,

$$\rho_P A_P v_P \Delta t = \rho_R A_R v_R \Delta t = \rho_Q A_Q v_Q \Delta t \quad (9.9)$$

For flow of incompressible fluids

$$\rho_P = \rho_R = \rho_Q$$

Equation (9.9) reduces to

$$A_P v_P = A_R v_R = A_Q v_Q \quad (9.10)$$

which is called the **equation of continuity** and it is a statement of conservation of mass in flow of incompressible fluids. In general

$$Av = \text{constant} \quad (9.11)$$

$Av$  gives the volume flux or flow rate and remains constant throughout the pipe of flow. Thus, at narrower portions where the streamlines are closely spaced, velocity increases and its vice versa. From (Fig 9.7b) it is clear that  $A_R > A_Q$  or  $v_R < v_Q$ , the fluid is accelerated while passing from R to Q. This is associated with a change in pressure in fluid flow in horizontal pipes.

Steady flow is achieved at low flow speeds. Beyond a limiting value, called critical speed, this flow loses steadiness and becomes **turbulent**. One sees this when a fast flowing stream encounters rocks, small foamy whirlpool-like regions called 'white water rapids' are formed.

Figure 9.8 displays streamlines for some typical flows. For example, Fig. 9.8(a) describes a laminar flow where the velocities at different points in the fluid may have different magnitudes

but their directions are parallel. Figure 9.8 (b) gives a sketch of turbulent flow.

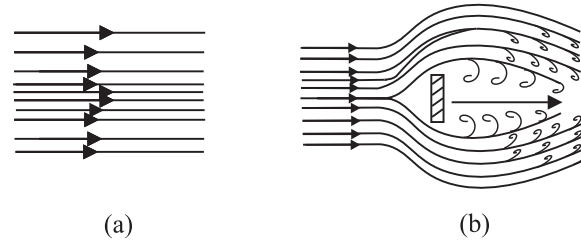

**Fig. 9.8** (a) Some streamlines for fluid flow. (b) A jet of air striking a flat plate placed perpendicular to it. This is an example of turbulent flow.

#### 9.4 BERNOULLI'S PRINCIPLE

Fluid flow is a complex phenomenon. But we can obtain some useful properties for steady or streamline flows using the conservation of energy.

Consider a fluid moving in a pipe of varying cross-sectional area. Let the pipe be at varying heights as shown in Fig. 9.9. We now suppose that an incompressible fluid is flowing through the pipe in a steady flow. Its velocity must change as a consequence of equation of continuity. A force is required to produce this acceleration, which is caused by the fluid surrounding it, the pressure must be different in different regions. Bernoulli's equation is a general expression that relates the pressure difference between two points in a pipe to both velocity changes (kinetic energy change) and elevation (height) changes (potential energy change). The Swiss Physicist Daniel Bernoulli developed this relationship in 1738.

Consider the flow at two regions 1 (i.e., BC) and 2 (i.e., DE). Consider the fluid initially lying between B and D. In an infinitesimal time interval  $\Delta t$ , this fluid would have moved. Suppose  $v_1$  is the speed at B and  $v_2$  at D, then fluid initially at B has moved a distance  $v_1 \Delta t$  to C ( $v_1 \Delta t$  is small enough to assume constant cross-section along BC). In the same interval  $\Delta t$  the fluid initially at D moves to E, a distance equal to  $v_2 \Delta t$ . Pressures  $P_1$  and  $P_2$  act as shown on the plane faces of areas  $A_1$  and  $A_2$  binding the two regions. The work done on the fluid at left end (BC) is  $W_1 = P_1 A_1 (v_1 \Delta t) = P_1 \Delta V$ . Since the same volume  $\Delta V$  passes through both the regions (from the equation of continuity) the work done by the fluid at the other end (DE) is  $W_2 = P_2 A_2 (v_2 \Delta t) = P_2 \Delta V$  or,

the work done on the fluid is  $-P_2\Delta V$ . So the total work done on the fluid is

$$W_1 - W_2 = (P_1 - P_2) \Delta V$$

Part of this work goes into changing the kinetic energy of the fluid, and part goes into changing the gravitational potential energy. If the density of the fluid is  $\rho$  and  $\Delta m = \rho A_1 v_1 \Delta t = \rho \Delta V$  is the mass passing through the pipe in time  $\Delta t$ , then change in gravitational potential energy is

$$\Delta U = \rho g \Delta V (h_2 - h_1)$$

The change in its kinetic energy is

$$\Delta K = \frac{1}{2} \rho \Delta V (v_2^2 - v_1^2)$$

We can employ the work - energy theorem (Chapter 6) to this volume of the fluid and this yields

$$(P_1 - P_2) \Delta V = \frac{1}{2} \rho \Delta V (v_2^2 - v_1^2) + \rho g \Delta V (h_2 - h_1)$$

We now divide each term by  $\Delta V$  to obtain

$$(P_1 - P_2) = \frac{1}{2} \rho (v_2^2 - v_1^2) + \rho g (h_2 - h_1)$$

We can rearrange the above terms to obtain

$$P_1 + \frac{1}{2} \rho v_1^2 + \rho g h_1 = P_2 + \frac{1}{2} \rho v_2^2 + \rho g h_2 \quad (9.12)$$

This is **Bernoulli's equation**. Since 1 and 2 refer to any two locations along the pipeline, we may write the expression in general as

$$P + \frac{1}{2} \rho v^2 + \rho g h = \text{constant} \quad (9.13)$$

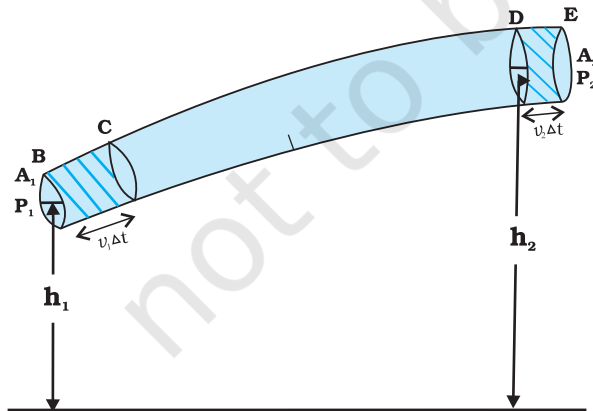

**Fig. 9.9** The flow of an ideal fluid in a pipe of varying cross section. The fluid in a section of length  $v_1 \Delta t$  moves to the section of length  $v_2 \Delta t$  in time  $\Delta t$ .

In words, the Bernoulli's relation may be stated as follows: As we move along a streamline the sum of the pressure ( $P$ ), the kinetic energy

per unit volume  $\left(\frac{\rho v^2}{2}\right)$  and the potential energy

per unit volume ( $\rho g h$ ) remains a constant.

Note that in applying the energy conservation principle, there is an assumption that no energy is lost due to friction. But in fact, when fluids flow, some energy does get lost due to internal friction. This arises due to the fact that in a fluid flow, the different layers of the fluid flow with different velocities. These layers exert frictional forces on each other resulting in a loss of energy. This property of the fluid is called viscosity and is discussed in more detail in a later section. The lost kinetic energy of the fluid gets converted into heat energy. Thus, Bernoulli's equation ideally applies to fluids with zero viscosity or non-viscous fluids. Another restriction on application of Bernoulli theorem is that the fluids must be incompressible, as the elastic energy of the fluid is also not taken into consideration. In practice, it has a large number of useful applications and can help explain a wide variety of phenomena for low viscosity incompressible fluids. Bernoulli's equation also does not hold for non-steady or turbulent flows, because in that situation velocity and pressure are constantly fluctuating in time.

When a fluid is at rest i.e., its velocity is zero everywhere, Bernoulli's equation becomes

$$P_1 + \rho g h_1 = P_2 + \rho g h_2$$

$$(P_1 - P_2) = \rho g (h_2 - h_1)$$

which is same as Eq. (9.6).

#### 9.4.1 Speed of Efflux: Torricelli's Law

The word efflux means fluid outflow. Torricelli discovered that the speed of efflux from an open tank is given by a formula identical to that of a freely falling body. Consider a tank containing a liquid of density  $\rho$  with a small hole in its side at a height  $y_1$  from the bottom (see Fig. 9.10). The air above the liquid, whose surface is at height  $y_2$ , is at pressure  $P$ . From the equation of continuity [Eq. (9.10)] we have

$$v_1 A_1 = v_2 A_2$$

$$v_2 = \frac{A_1}{A_2} v_1$$

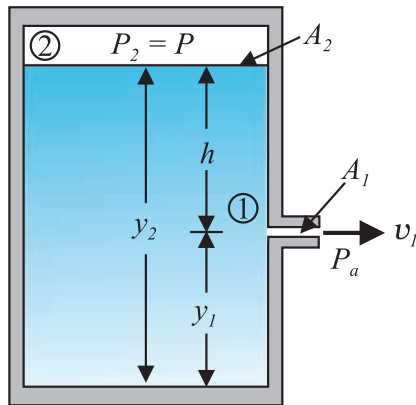

**Fig. 9.10** Torricelli's law. The speed of efflux,  $v_1$ , from the side of the container is given by the application of Bernoulli's equation. If the container is open at the top to the atmosphere then  $v_1 = \sqrt{2gh}$ .

If the cross-sectional area of the tank  $A_2$  is much larger than that of the hole ( $A_2 \gg A_1$ ), then we may take the fluid to be approximately at rest at the top, i.e.,  $v_2 = 0$ . Now, applying the Bernoulli equation at points 1 and 2 and noting that at the hole  $P_1 = P_a$ , the atmospheric pressure, we have from Eq. (9.12)

$$P_a + \frac{1}{2} \rho v_1^2 + \rho g y_1 = P + \rho g y_2$$

Taking  $y_2 - y_1 = h$  we have

$$v_1 = \sqrt{2gh + \frac{2(P - P_a)}{\rho}} \quad (9.14)$$

When  $P \gg P_a$  and  $2gh$  may be ignored, the speed of efflux is determined by the container pressure. Such a situation occurs in rocket propulsion. On the other hand, if the tank is open to the atmosphere, then  $P = P_a$  and

$$v_1 = \sqrt{2gh} \quad (9.15)$$

This is also the speed of a freely falling body. Equation (9.15) represents **Torricelli's law**.

#### 9.4.2 Dynamic Lift

Dynamic lift is the force that acts on a body, such as airplane wing, a hydrofoil or a spinning ball, by virtue of its motion through a fluid. In many games such as cricket, tennis, baseball, or golf, we notice that a spinning ball deviates

from its parabolic trajectory as it moves through air. This deviation can be partly explained on the basis of Bernoulli's principle.

(i) **Ball moving without spin:** Fig. 9.11(a) shows the streamlines around a non-spinning ball moving relative to a fluid. From the symmetry of streamlines it is clear that the velocity of fluid (air) above and below the ball at corresponding points is the same resulting in zero pressure difference. The air therefore, exerts no upward or downward force on the ball.

(ii) **Ball moving with spin:** A ball which is spinning drags air along with it. If the surface is rough more air will be dragged. Fig. 9.11(b) shows the streamlines of air for a ball which is moving and spinning at the same time. The ball is moving forward and relative to it the air is moving backwards. Therefore, the velocity of air above the ball relative to the ball is larger and below it is smaller (see Section 9.3). The stream lines, thus, get crowded above and rarified below.

This difference in the velocities of air results in the pressure difference between the lower and upper faces and there is a net upward force on the ball. This dynamic lift due to spinning is called **Magnus effect**.

**Aerofoil or lift on aircraft wing:** Figure 9.11 (c) shows an aerofoil, which is a solid piece shaped to provide an upward dynamic lift when it moves horizontally through air. The cross-section of the wings of an aeroplane looks somewhat like the aerofoil shown in Fig. 9.11 (c) with streamlines around it. When the aerofoil moves against the wind, the orientation of the wing relative to flow direction causes the streamlines to crowd together above the wing more than those below it. The flow speed on top is higher than that below it. There is an upward force resulting in a dynamic lift of the wings and this balances the weight of the plane. The following example illustrates this.

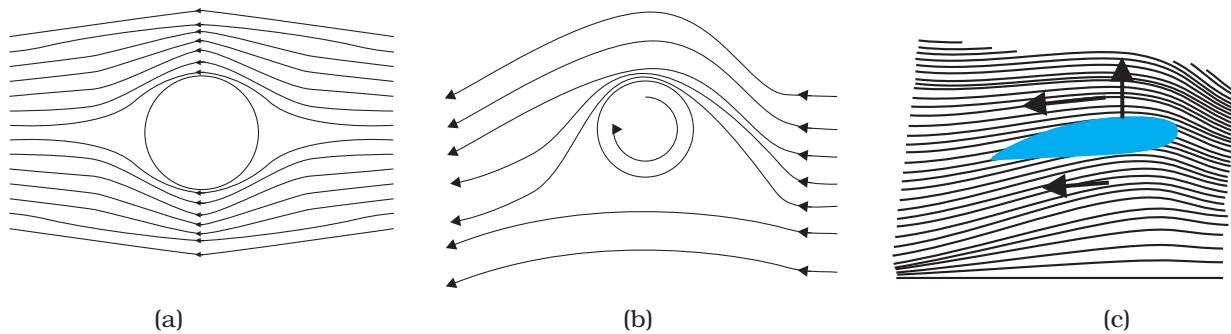

**Fig 9.11** (a) Fluid streaming past a static sphere. (b) Streamlines for a fluid around a sphere spinning clockwise. (c) Air flowing past an aerofoil.

**Example 9.7** A fully loaded Boeing aircraft has a mass of  $3.3 \times 10^5$  kg. Its total wing area is  $500 \text{ m}^2$ . It is in level flight with a speed of  $960 \text{ km/h}$ . (a) Estimate the pressure difference between the lower and upper surfaces of the wings (b) Estimate the fractional increase in the speed of the air on the upper surface of the wing relative to the lower surface. [The density of air is  $\rho = 1.2 \text{ kg m}^{-3}$ ]

**Answer** (a) The weight of the Boeing aircraft is balanced by the upward force due to the pressure difference

$$\Delta P A = 3.3 \times 10^5 \text{ kg} \times 9.8$$

$$\begin{aligned} \Delta P &= (3.3 \times 10^5 \text{ kg} \times 9.8 \text{ m s}^{-2}) / 500 \text{ m}^2 \\ &= 6.5 \times 10^3 \text{ Nm}^{-2} \end{aligned}$$

(b) We ignore the small height difference between the top and bottom sides in Eq. (9.12). The pressure difference between them is then

$$\Delta P = \frac{\rho}{2} (v_2^2 - v_1^2)$$

where  $v_2$  is the speed of air over the upper surface and  $v_1$  is the speed under the bottom surface.

$$(v_2 - v_1) = \frac{2\Delta P}{\rho(v_2 + v_1)}$$

Taking the average speed

$v_{\text{av}} = (v_2 + v_1)/2 = 960 \text{ km/h} = 267 \text{ m s}^{-1}$ ,  
we have

$$(v_2 - v_1) / v_{\text{av}} = \frac{\Delta P}{\rho v_{\text{av}}^2} \approx 0.08$$

The speed above the wing needs to be only 8 % higher than that below. ◀

## 9.5 VISCOSITY

Most of the fluids are not ideal ones and offer some resistance to motion. This resistance to fluid motion is like an internal friction analogous to friction when a solid moves on a surface. It is called viscosity. This force exists when there is relative motion between layers of the liquid. Suppose we consider a fluid like oil enclosed between two glass plates as shown in Fig. 9.12 (a). The bottom plate is fixed while the top plate is moved with a constant velocity  $\mathbf{v}$  relative to the fixed plate. If oil is replaced by honey, a greater force is required to move the plate with the same velocity. Hence we say that honey is more viscous than oil. The fluid in contact with a surface has the same velocity as that of the surfaces. Hence, the layer of the liquid in contact with top surface moves with a velocity  $\mathbf{v}$  and the layer of the liquid in contact with the fixed surface is stationary. The velocities of layers increase uniformly from bottom (zero velocity) to the top layer (velocity  $\mathbf{v}$ ). For any layer of liquid, its upper layer pulls it forward while lower layer pulls it backward. This results in force between the layers. This

type of flow is known as laminar. The layers of liquid slide over one another as the pages of a book do when it is placed flat on a table and a horizontal force is applied to the top cover. When a fluid is flowing in a pipe or a tube, then velocity of the liquid layer along the axis of the tube is maximum and decreases gradually as we move towards the walls where it becomes zero, Fig. 9.12 (b). The velocity on a cylindrical surface in a tube is constant.

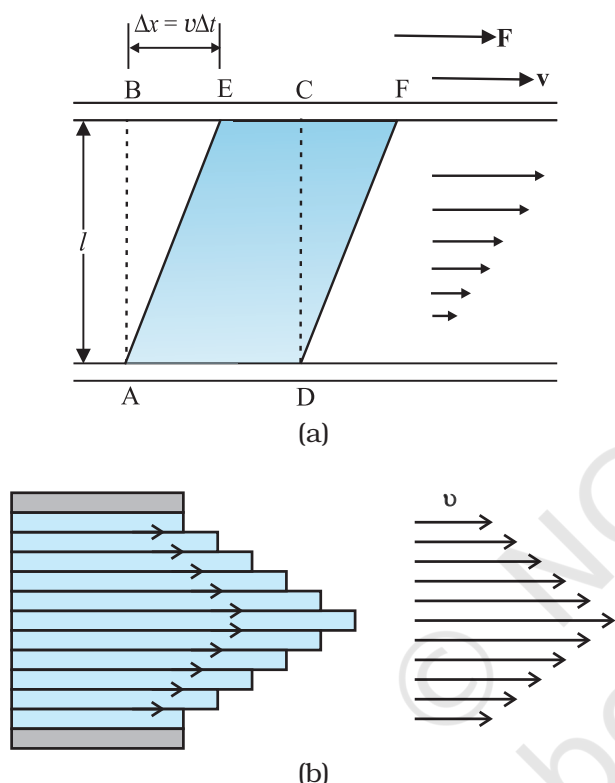

**Fig 9.12** (a) A layer of liquid sandwiched between two parallel glass plates, in which the lower plate is fixed and the upper one is moving to the right with velocity  $v$   
(b) velocity distribution for viscous flow in a pipe.

On account of this motion, a portion of liquid, which at some instant has the shape ABCD, take the shape of AEFD after short interval of time ( $\Delta t$ ). During this time interval the liquid has undergone a shear strain of  $\Delta x/l$ . Since, the strain in a flowing fluid increases with time continuously. Unlike a solid, here the stress is found experimentally to depend on 'rate of

change of strain' or 'strain rate' i.e.  $\Delta x/(l \Delta t)$  or  $v/l$  instead of strain itself. The coefficient of viscosity (pronounced 'eta') for a fluid is defined as the ratio of shearing stress to the strain rate.

$$\eta = \frac{F/A}{v/l} = \frac{Fl}{vA} \quad (9.16)$$

The SI unit of viscosity is poiseuille (Pl). Its other units are  $\text{N s m}^{-2}$  or  $\text{Pa s}$ . The dimensions of viscosity are  $[\text{ML}^{-1}\text{T}^{-1}]$ . Generally, thin liquids, like water, alcohol, etc., are less viscous than thick liquids, like coal tar, blood, glycerine, etc. The coefficients of viscosity for some common fluids are listed in Table 9.2. We point out two facts about blood and water that you may find interesting. As Table 9.2 indicates, blood is 'thicker' (more viscous) than water. Further, the relative viscosity ( $\eta/\eta_{\text{water}}$ ) of blood remains constant between  $0^\circ\text{C}$  and  $37^\circ\text{C}$ .

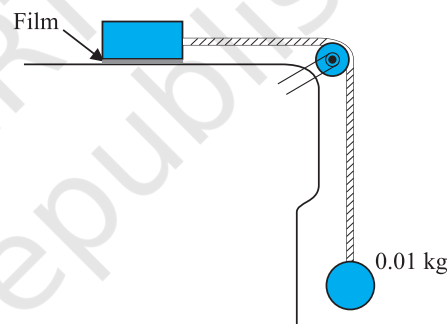

**Fig. 9.13** Measurement of the coefficient of viscosity of a liquid.

The viscosity of liquids decreases with temperature, while it increases in the case of gases.

**Example 9.8** A metal block of area  $0.10 \text{ m}^2$  is connected to a  $0.010 \text{ kg}$  mass via a string that passes over an ideal pulley (considered massless and frictionless), as in Fig. 9.13. A liquid with a film thickness of  $0.30 \text{ mm}$  is placed between the block and the table. When released the block moves to the right with a constant speed of  $0.085 \text{ m s}^{-1}$ . Find the coefficient of viscosity of the liquid.



**Answer** The metal block moves to the right because of the tension in the string. The tension  $T$  is equal in magnitude to the weight of the suspended mass  $m$ . Thus, the shear force  $F$  is

$$F = T = mg = 0.010 \text{ kg} \times 9.8 \text{ m s}^{-2} = 9.8 \times 10^{-2} \text{ N}$$

$$\text{Shear stress on the fluid} = F/A = \frac{9.8 \times 10^{-2}}{0.10} \text{ N/m}^2$$

$$\text{Strain rate} = \frac{v}{l} = \frac{0.085}{0.30 \times 10^{-3}}$$

$$\begin{aligned} h &= \frac{\text{stress}}{\text{strain rate}} \text{ s}^{-1} \\ &= \frac{(9.8 \times 10^{-2} \text{ N}) (0.30 \times 10^{-3} \text{ m})}{(0.085 \text{ m s}^{-1}) (0.10 \text{ m}^2)} \\ &= 3.46 \times 10^{-3} \text{ Pa s} \end{aligned}$$

**Table 9.2 The viscosities of some fluids**

Fluid	T(°C)	Viscosity (mPl)
Water	20	1.0
	100	0.3
Blood	37	2.7
	38	34
Machine Oil	16	113
	38	34
Glycerine	20	830
Honey	–	200
Air	0	0.017
	40	0.019

### 9.5.1 Stokes' Law

When a body falls through a fluid it drags the layer of the fluid in contact with it. A relative motion between the different layers of the fluid is set and, as a result, the body experiences a retarding force. Falling of a raindrop and swinging of a pendulum bob are some common examples of such motion. It is seen that the viscous force is proportional to the velocity of the object and is opposite to the direction of motion. The other quantities on which the force  $F$  depends are viscosity  $\eta$  of the fluid and radius  $a$  of the sphere. Sir George G. Stokes (1819–1903), an English scientist enunciated clearly the viscous drag force  $F$  as

$$F = 6\pi\eta av \quad (9.17)$$

This is known as Stokes' law. We shall not derive Stokes' law.

This law is an interesting example of retarding force, which is proportional to velocity. We can study its consequences on an object falling through a viscous medium. We consider a raindrop in air. It accelerates initially due to gravity. As the velocity increases, the retarding force also increases. Finally, when viscous force plus buoyant force becomes equal to the force due to gravity, the net force becomes zero and so does the acceleration. The sphere (raindrop) then descends with a constant velocity. Thus, in equilibrium, this terminal velocity  $v_t$  is given by

$$6\pi\eta av_t = (4\pi/3) a^3 (\rho - \sigma)g$$

where  $\rho$  and  $\sigma$  are mass densities of sphere and the fluid, respectively. We obtain

$$v_t = 2a^2 (\rho - \sigma)g / (9\eta) \quad (9.18)$$

So the terminal velocity  $v_t$  depends on the square of the radius of the sphere and inversely on the viscosity of the medium.

You may like to refer back to Example 6.2 in this context.

**Example 9.9** The terminal velocity of a copper ball of radius 2.0 mm falling through a tank of oil at 20°C is 6.5 cm s<sup>-1</sup>. Compute the viscosity of the oil at 20°C. Density of oil is 1.5 × 10<sup>3</sup> kg m<sup>-3</sup>, density of copper is 8.9 × 10<sup>3</sup> kg m<sup>-3</sup>.

**Answer** We have  $v_t = 6.5 \times 10^{-2} \text{ ms}^{-1}$ ,  $a = 2 \times 10^{-3} \text{ m}$ ,  $g = 9.8 \text{ ms}^{-2}$ ,  $\rho = 8.9 \times 10^3 \text{ kg m}^{-3}$ ,

$\sigma = 1.5 \times 10^3 \text{ kg m}^{-3}$ . From Eq. (9.18)

$$\begin{aligned} \eta &= \frac{2}{9} \times \frac{(2 \times 10^{-3})^2 \text{ m}^2 \times 9.8 \text{ m s}^{-2}}{6.5 \times 10^{-2} \text{ m s}^{-1}} \times 7.4 \times 10^3 \text{ kg m}^{-3} \\ &= 9.9 \times 10^{-1} \text{ kg m}^{-1} \text{ s}^{-1} \end{aligned}$$

### 9.6 SURFACE TENSION

You must have noticed that, oil and water do not mix; water wets you and me but not ducks; mercury does not wet glass but water sticks to it, oil rises up a cotton wick, inspite of gravity,

Sap and water rise up to the top of the leaves of the tree, hair of a paint brush do not cling together when dry and even when dipped in water but form a fine tip when taken out of it. All these and many more such experiences are related with the free surfaces of liquids. As liquids have no definite shape but have a definite volume, they acquire a free surface when poured in a container. These surfaces possess some additional energy. This phenomenon is known as surface tension and it is concerned with only liquid as gases do not have free surfaces. Let us now understand this phenomena.

### 9.6.1 Surface Energy

A liquid stays together because of attraction between molecules. Consider a molecule well inside a liquid. The intermolecular distances are such that it is attracted to all the surrounding molecules [Fig. 9.14(a)]. This attraction results in a negative potential energy for the molecule, which depends on the number and distribution of molecules around the chosen one. But the average potential energy of all the molecules is the same. This is supported by the fact that to take a collection of such molecules (the liquid) and to disperse them far away from each other in order to evaporate or vaporise, the heat of evaporation required is quite large. For water it is of the order of 40 kJ/mol.

Let us consider a molecule near the surface Fig. 9.14(b). Only lower half side of it is surrounded by liquid molecules. There is some negative potential energy due to these, but obviously it is less than that of a molecule in bulk, i.e., the one fully inside. Approximately it is half of the latter. Thus, molecules on a liquid surface have some extra energy in comparison to molecules in the interior. A liquid, thus, tends to have the least surface area which external conditions permit. Increasing surface area requires energy. Most surface phenomenon can be understood in terms of this fact. What is the energy required for having a molecule at the surface? As mentioned above, roughly it is half the energy required to remove it entirely from the liquid i.e., half the heat of evaporation.

Finally, what is a surface? Since a liquid consists of molecules moving about, there cannot be a perfectly sharp surface. The density of the liquid molecules drops rapidly to zero around  $z = 0$  as we move along the direction indicated Fig 9.14 (c) in a distance of the order of a few molecular sizes.

### 9.6.2 Surface Energy and Surface Tension

As we have discussed that an extra energy is associated with surface of liquids, the creation of more surface (spreading of surface) keeping other things like volume fixed requires a

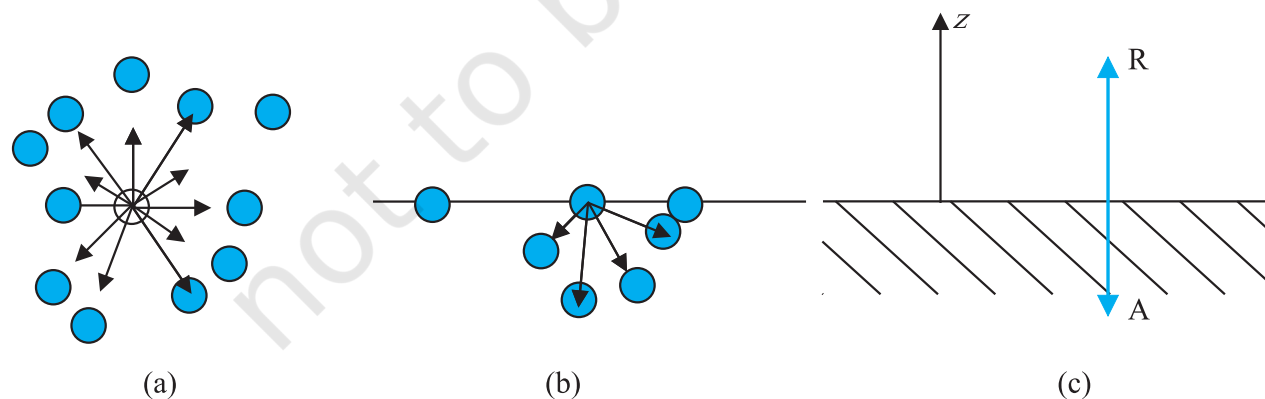

**Fig. 9.14** Schematic picture of molecules in a liquid, at the surface and balance of forces. (a) Molecule inside a liquid. Forces on a molecule due to others are shown. Direction of arrows indicates attraction of repulsion. (b) Same, for a molecule at a surface. (c) Balance of attractive (A) and repulsive (R) forces.

horizontal liquid film ending in bar free to slide over parallel guides Fig (9.15).

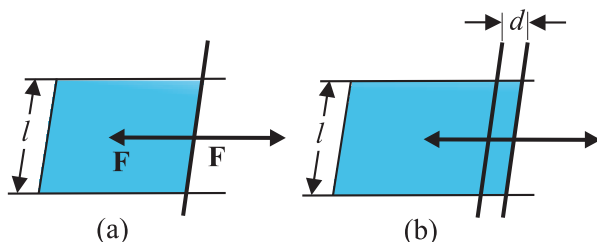

**Fig. 9.15** Stretching a film. (a) A film in equilibrium; (b) The film stretched an extra distance.

Suppose that we move the bar by a small distance  $d$  as shown. Since the area of the surface increases, the system now has more energy, this means that some work has been done against an internal force. Let this internal force be  $\mathbf{F}$ , the work done by the applied force is  $\mathbf{F} \cdot \mathbf{d} = Fd$ . From conservation of energy, this is stored as additional energy in the film. If the surface energy of the film is  $S$  per unit area, the extra area is  $2dl$ . A film has two sides and the liquid in between, so there are two surfaces and the extra energy is

$$S(2dl) = Fd \quad (9.19)$$

$$\text{Or, } S = Fd/2dl = F/2l \quad (9.20)$$

This quantity  $S$  is the magnitude of surface tension. It is equal to the surface energy per unit area of the liquid interface and is also equal to the force per unit length exerted by the fluid on the movable bar.

So far we have talked about the surface of one liquid. More generally, we need to consider fluid surface in contact with other fluids or solid surfaces. The surface energy in that case depends on the materials on both sides of the surface. For example, if the molecules of the materials attract each other, surface energy is reduced while if they repel each other the surface energy is increased. Thus, more appropriately, the surface energy is the energy of the interface between two materials and depends on both of them.

We make the following observations from above:

- (i) Surface tension is a force per unit length (or surface energy per unit area) acting in the plane of the interface between the plane of the liquid and any other substance; it also is the extra energy that the molecules at the interface have as compared to molecules in the interior.
- (ii) At any point on the interface besides the boundary, we can draw a line and imagine equal and opposite surface tension forces  $S$  per unit length of the line acting perpendicular to the line, in the plane of the interface. The line is in equilibrium. To be more specific, imagine a line of atoms or molecules at the surface. The atoms to the left pull the line towards them; those to the right pull it towards them! This line of atoms is in equilibrium under tension. If the line really marks the end of the interface, as in Figure 9.14 (a) and (b) there is only the force  $S$  per unit length acting inwards.

Table 9.3 gives the surface tension of various liquids. The value of surface tension depends on temperature. Like viscosity, the surface tension of a liquid usually falls with temperature.

**Table 9.3** Surface tension of some liquids at the temperatures indicated with the heats of the vaporisation

Liquid	Temp (°C)	Surface Tension (N/m)	Heat of vaporisation (kJ/mol)
Helium	-270	0.000239	0.115
Oxygen	-183	0.0132	7.1
Ethanol	20	0.0227	40.6
Water	20	0.0727	44.16
Mercury	20	0.4355	63.2

A fluid will stick to a solid surface if the surface energy between fluid and the solid is smaller than the sum of surface energies between solid-air, and fluid-air. Now there is attraction between the solid surface and the liquid. It can be directly measured experimentally as schematically shown in Fig. 9.16. A flat vertical glass plate, below which a vessel of some liquid is kept, forms one arm of the balance. The plate is balanced by weights on the other side, with its horizontal edge just over water. The vessel is raised slightly till the liquid just touches the glass plate and pulls it down a little because of surface tension. Weights are added till the plate just clears water.

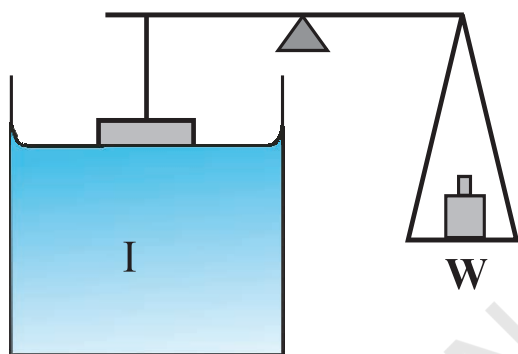

**Fig. 9.16** Measuring Surface Tension.

Suppose the additional weight required is  $W$ . Then from Eq. 9.20 and the discussion given there, the surface tension of the liquid-air interface is

$$S_{la} = (W/2l) = (mg/2l) \quad (9.21)$$

where  $m$  is the extra mass and  $l$  is the length of the plate edge. The subscript (la) emphasises the fact that the liquid-air interface tension is involved.

### 9.6.3 Angle of Contact

The surface of liquid near the plane of contact, with another medium is in general curved. The angle between tangent to the liquid surface at the point of contact and solid surface inside the liquid is termed as angle of contact. It is denoted

by  $\theta$ . It is different at interfaces of different pairs of liquids and solids. The value of  $\theta$  determines whether a liquid will spread on the surface of a solid or it will form droplets on it. For example, water forms droplets on lotus leaf as shown in Fig. 9.17 (a) while spreads over a clean plastic plate as shown in Fig. 9.17(b).

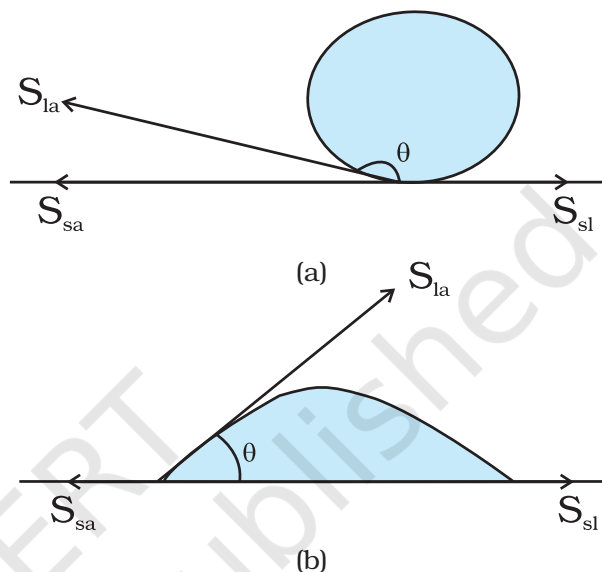

**Fig. 9.17** Different shapes of water drops with interfacial tensions (a) on a lotus leaf (b) on a clean plastic plate.

We consider the three interfacial tensions at all the three interfaces, liquid-air, solid-air and solid-liquid denoted by  $S_{la}$ ,  $S_{sa}$  and  $S_{sl}$ , respectively as given in Fig. 9.17 (a) and (b). At the line of contact, the surface forces between the three media must be in equilibrium. From the Fig. 9.17(b) the following relation is easily derived.

$$S_{la} \cos \theta + S_{sl} = S_{sa} \quad (9.22)$$

The angle of contact is an obtuse angle if  $S_{sl} > S_{la}$  as in the case of water-leaf interface while it is an acute angle if  $S_{sl} < S_{la}$  as in the case of water-plastic interface. When  $\theta$  is an obtuse angle then molecules of liquids are attracted strongly to themselves and weakly to those of solid, it costs a lot of energy to create a liquid-solid surface, and liquid then does not wet the solid. This is what happens with water on a waxy or oily surface, and with mercury on

any surface. On the other hand, if the molecules of the liquid are strongly attracted to those of the solid, this will reduce  $S_{sl}$  and therefore,  $\cos \theta$  may increase or  $\theta$  may decrease. In this case  $\theta$  is an acute angle. This is what happens for water on glass or on plastic and for kerosene oil on virtually anything (it just spreads). Soaps, detergents and dyeing substances are wetting agents. When they are added the angle of contact becomes small so that these may penetrate well and become effective. Water proofing agents on the other hand are added to create a large angle of contact between the water and fibres.

### 9.6.4 Drops and Bubbles

One consequence of surface tension is that free liquid drops and bubbles are spherical if effects of gravity can be neglected. You must have seen this especially clearly in small drops just formed in a high-speed spray or jet, and in soap bubbles blown by most of us in childhood. Why are drops and bubbles spherical? What keeps soap bubbles stable?

As we have been saying repeatedly, a liquid-air interface has energy, so for a given volume the surface with minimum energy is the one with the least area. The sphere has this property. Though it is out of the scope of this book, but you can check that a sphere is better than at least a cube in this respect! So, if gravity and other forces (e.g. air resistance) were ineffective, liquid drops would be spherical.

Another interesting consequence of surface tension is that the pressure inside a spherical drop Fig. 9.18(a) is more than the pressure outside. Suppose a spherical drop of radius  $r$  is in equilibrium. If its radius increase by  $\Delta r$ . The extra surface energy is

$$[4\pi(r + \Delta r)^2 - 4\pi r^2] S_{la} = 8\pi r \Delta r S_{la} \quad (9.23)$$

If the drop is in equilibrium this energy cost is balanced by the energy gain due to expansion under the pressure difference ( $P_i - P_o$ ) between the inside of the bubble and the outside. The work done is

$$W = (P_i - P_o) 4\pi r^2 \Delta r \quad (9.24)$$

so that

$$(P_i - P_o) = (2 S_{la} / r) \quad (9.25)$$

In general, for a liquid-gas interface, the convex side has a higher pressure than the concave side. For example, an air bubble in a liquid, would have higher pressure inside it. See Fig 9.18 (b).

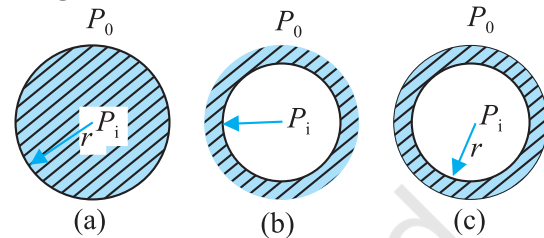

**Fig. 9.18** Drop, cavity and bubble of radius  $r$ .

A bubble Fig 9.18 (c) differs from a drop and a cavity; in this it has two interfaces. Applying the above argument we have for a bubble

$$(P_i - P_o) = (4 S_{la} / r) \quad (9.26)$$

This is probably why you have to blow hard, but not too hard, to form a soap bubble. A little extra air pressure is needed inside!

### 9.6.5 Capillary Rise

One consequence of the pressure difference across a curved liquid-air interface is the well-known effect that water rises up in a narrow tube in spite of gravity. The word capilla means hair in Latin; if the tube were hair thin, the rise would be very large. To see this, consider a vertical capillary tube of circular cross section (radius  $a$ ) inserted into an open vessel of water (Fig. 9.19). The contact angle between water and

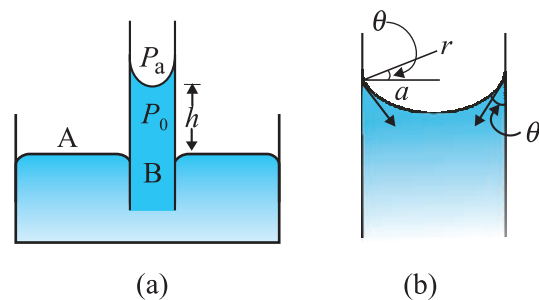

**Fig. 9.19** Capillary rise, (a) Schematic picture of a narrow tube immersed water. (b) Enlarged picture near interface.

glass is acute. Thus the surface of water in **the capillary is concave. This means that there is a pressure difference between the two sides of the top surface. This is given by**

$$\begin{aligned}(P_i - P_o) &= (2S/r) = 2S/(a \sec \theta) \\ &= (2S/a) \cos \theta\end{aligned}\quad (9.27)$$

**Thus the pressure of the water inside the tube, just at the meniscus (air-water interface) is less than the atmospheric pressure. Consider the two points A and B in Fig. 9.19(a). They must be at the same pressure, namely**

$$P_o + h \rho g = P_i = P_A \quad (9.28)$$

**where  $\rho$  is the density of water and  $h$  is called the capillary rise** [Fig. 9.19(a)]. Using Eq. (9.27) and (9.28) we have

$$h \rho g = (P_i - P_o) = (2S \cos \theta)/a \quad (9.29)$$

The discussion here, and the Eqs. (9.24) and (9.25) make it clear that the capillary rise is due to surface tension. It is larger, for a smaller  $a$ . Typically it is of the order of a few cm for fine capillaries. For example, if  $a = 0.05$  cm, using the value of surface tension for water (Table 9.3), we find that

$$\begin{aligned}h &= 2S/(\rho g a) \\ &= \frac{2 \times (0.073 \text{ N m}^{-1})}{(10^3 \text{ kg m}^{-3})(9.8 \text{ m s}^{-2})(5 \times 10^{-4} \text{ m})} \\ &= 2.98 \times 10^{-2} \text{ m} = 2.98 \text{ cm}\end{aligned}$$

Notice that if the liquid meniscus is convex, as for mercury, i.e., if  $\cos \theta$  is negative then from Eq. (9.28) for example, it is clear that the liquid will be lower in the capillary!

► **Example 9.10** The lower end of a capillary tube of diameter 2.00 mm is dipped 8.00 cm below the surface of water in a beaker. What is the pressure required in the tube in order to blow a hemispherical bubble at its end in water? The surface tension of water at temperature of the experiments is  $7.30 \times 10^{-2} \text{ Nm}^{-1}$ . 1 atmospheric pressure =  $1.01 \times 10^5 \text{ Pa}$ , density of water =  $1000 \text{ kg/m}^3$ ,  $g = 9.80 \text{ m s}^{-2}$ . Also calculate the excess pressure.

**Answer** The excess pressure in a bubble of gas in a liquid is given by  $2S/r$ , where  $S$  is the surface tension of the liquid-gas interface. You should note there is only one liquid surface in this case. (For a bubble of liquid in a gas, there are two liquid surfaces, so the formula for excess pressure in that case is  $4S/r$ .) The radius of the bubble is  $r$ . Now the pressure outside the bubble  $P_o$  equals atmospheric pressure plus the pressure due to 8.00 cm of water column. That is

$$\begin{aligned}P_o &= (1.01 \times 10^5 \text{ Pa} + 0.08 \text{ m} \times 1000 \text{ kg m}^{-3} \\ &\quad \times 9.80 \text{ m s}^{-2}) \\ &= 1.01784 \times 10^5 \text{ Pa}\end{aligned}$$

$$\begin{aligned}\text{Therefore, the pressure inside the bubble is} \\ P_i &= P_o + 2S/r \\ &= 1.01784 \times 10^5 \text{ Pa} + (2 \times 7.3 \times 10^{-2} \text{ Pa m} / 10^{-3} \text{ m}) \\ &= (1.01784 + 0.00146) \times 10^5 \text{ Pa} \\ &= 1.02 \times 10^5 \text{ Pa}\end{aligned}$$

where the radius of the bubble is taken to be equal to the radius of the capillary tube, since the bubble is hemispherical! (The answer has been rounded off to three significant figures.) The excess pressure in the bubble is 146 Pa. ◀

### SUMMARY

1. The basic property of a fluid is that it can flow. The fluid does not have any resistance to change of its shape. Thus, the shape of a fluid is governed by the shape of its container.
2. A liquid is incompressible and has a free surface of its own. A gas is compressible and it expands to occupy all the space available to it.
3. If  $F$  is the normal force exerted by a fluid on an area  $A$  then the average pressure  $P_{av}$  is defined as the ratio of the force to area

$$P_{av} = \frac{F}{A}$$

4. The unit of the pressure is the pascal (Pa). It is the same as  $\text{N m}^{-2}$ . Other common units of pressure are  
 $1 \text{ atm} = 1.01 \times 10^5 \text{ Pa}$   
 $1 \text{ bar} = 10^5 \text{ Pa}$   
 $1 \text{ torr} = 133 \text{ Pa} = 0.133 \text{ kPa}$   
 $1 \text{ mm of Hg} = 1 \text{ torr} = 133 \text{ Pa}$
5. *Pascal's law* states that: Pressure in a fluid at rest is same at all points which are at the same height. A change in pressure applied to an enclosed fluid is transmitted undiminished to every point of the fluid and the walls of the containing vessel.
6. The pressure in a fluid varies with depth  $h$  according to the expression  
 $P = P_a + \rho gh$   
 where  $\rho$  is the density of the fluid, assumed uniform.
7. The volume of an incompressible fluid passing any point every second in a pipe of non uniform cross section is the same in the steady flow.  
 $vA = \text{constant}$  ( $v$  is the velocity and  $A$  is the area of cross section)  
 The equation is due to mass conservation in incompressible fluid flow.
8. *Bernoulli's principle* states that as we move along a streamline, the sum of the pressure ( $P$ ), the kinetic energy per unit volume ( $\rho v^2/2$ ) and the potential energy per unit volume ( $\rho gy$ ) remains a constant.  
 $P + \rho v^2/2 + \rho gy = \text{constant}$   
 The equation is basically the conservation of energy applied to non viscous fluid motion in steady state. There is no fluid which have zero viscosity, so the above statement is true only approximately. The viscosity is like friction and converts the kinetic energy to heat energy.
9. Though shear strain in a fluid does not require shear stress, when a shear stress is applied to a fluid, the motion is generated which causes a shear strain growing with time. The ratio of the shear stress to the time rate of shearing strain is known as coefficient of viscosity,  $\eta$ .  
 where symbols have their usual meaning and are defined in the text.
10. *Stokes' law* states that the viscous drag force  $\mathbf{F}$  on a sphere of radius  $a$  moving with velocity  $\mathbf{v}$  through a fluid of viscosity is,  $\mathbf{F} = 6\pi\eta a\mathbf{v}$ .
11. Surface tension is a force per unit length (or surface energy per unit area) acting in the plane of interface between the liquid and the bounding surface. It is the extra energy that the molecules at the interface have as compared to the interior.

#### POINTS TO PONDER

1. Pressure is a *scalar quantity*. The definition of the pressure as “force per unit area” may give one false impression that pressure is a vector. The “force” in the numerator of the definition is the component of the force normal to the area upon which it is impressed. While describing fluids as a concept, shift from particle and rigid body mechanics is required. We are concerned with properties that vary from point to point in the fluid.
2. One should not think of pressure of a fluid as being exerted only on a solid like the walls of a container or a piece of solid matter immersed in the fluid. Pressure exists at all points in a fluid. An element of a fluid (such as the one shown in Fig. 9.4) is in equilibrium because the pressures exerted on the various faces are equal.

3. The expression for pressure  
 $P = P_a + \rho gh$   
 holds true if fluid is incompressible. Practically speaking it holds for liquids, which are largely incompressible and hence  $\rho$  is a constant with height.
4. The gauge pressure is the difference of the actual pressure and the atmospheric pressure.  
 $P - P_a = P_g$   
 Many pressure-measuring devices measure the gauge pressure. These include the tyre pressure gauge and the blood pressure gauge (sphygmomanometer).
5. A streamline is a map of fluid flow. In a steady flow two streamlines do not intersect as it means that the fluid particle will have two possible velocities at the point.
6. Bernoulli's principle does not hold in presence of viscous drag on the fluid. The work done by this dissipative viscous force must be taken into account in this case, and  $P_2$  [Fig. 9.9] will be lower than the value given by Eq. (9.12).
7. As the temperature rises the atoms of the liquid become more mobile and the coefficient of viscosity,  $\eta$  falls. In a gas the temperature rise increases the random motion of atoms and  $\eta$  increases.
8. Surface tension arises due to excess potential energy of the molecules on the surface in comparison to their potential energy in the interior. Such a surface energy is present at the interface separating two substances at least one of which is a fluid. It is not the property of a single fluid alone.

Physical Quantity	Symbol	Dimensions	Unit	Remarks
Pressure	$P$	$[M L^{-1} T^{-2}]$	pascal (Pa)	1 atm = $1.013 \times 10^5$ Pa, Scalar
Density	$\rho$	$[M L^{-3}]$	kg m <sup>-3</sup>	Scalar
Specific Gravity		No	No	$\frac{\rho_{\text{substance}}}{\rho_{\text{water}}}$ , Scalar
Co-efficient of viscosity	$\eta$	$[M L^{-1} T^{-1}]$	Pa s or poiseulles (Pl)	Scalar
Surface Tension	$S$	$[M T^{-2}]$	N m <sup>-1</sup>	Scalar

### EXERCISES

- 9.1 Explain why
  - (a) The blood pressure in humans is greater at the feet than at the brain
  - (b) Atmospheric pressure at a height of about 6 km decreases to nearly half of its value at the sea level, though the height of the atmosphere is more than 100 km
  - (c) Hydrostatic pressure is a scalar quantity even though pressure is force divided by area.
- 9.2 Explain why
  - (a) The angle of contact of mercury with glass is obtuse, while that of water with glass is acute.
  - (b) Water on a clean glass surface tends to spread out while mercury on the same surface tends to form drops. (Put differently, water wets glass while mercury does not.)



- (c) Surface tension of a liquid is independent of the area of the surface  
 (d) Water with detergent dissolved in it should have small angles of contact.  
 (e) A drop of liquid under no external forces is always spherical in shape
- 9.3** Fill in the blanks using the word(s) from the list appended with each statement:  
 (a) Surface tension of liquids generally ... with temperatures (increases / decreases)  
 (b) Viscosity of gases ... with temperature, whereas viscosity of liquids ... with temperature (increases / decreases)  
 (c) For solids with elastic modulus of rigidity, the shearing force is proportional to ... , while for fluids it is proportional to ... (shear strain / rate of shear strain)  
 (d) For a fluid in a steady flow, the increase in flow speed at a constriction follows (conservation of mass / Bernoulli's principle)  
 (e) For the model of a plane in a wind tunnel, turbulence occurs at a ... speed for turbulence for an actual plane (greater / smaller)
- 9.4** Explain why  
 (a) To keep a piece of paper horizontal, you should blow over, not under, it  
 (b) When we try to close a water tap with our fingers, fast jets of water gush through the openings between our fingers  
 (c) The size of the needle of a syringe controls flow rate better than the thumb pressure exerted by a doctor while administering an injection  
 (d) A fluid flowing out of a small hole in a vessel results in a backward thrust on the vessel  
 (e) A spinning cricket ball in air does not follow a parabolic trajectory
- 9.5** A 50 kg girl wearing high heel shoes balances on a single heel. The heel is circular with a diameter 1.0 cm. What is the pressure exerted by the heel on the horizontal floor?
- 9.6** Toricelli's barometer used mercury. Pascal duplicated it using French wine of density  $984 \text{ kg m}^{-3}$ . Determine the height of the wine column for normal atmospheric pressure.
- 9.7** A vertical off-shore structure is built to withstand a maximum stress of  $10^9 \text{ Pa}$ . Is the structure suitable for putting up on top of an oil well in the ocean? Take the depth of the ocean to be roughly 3 km, and ignore ocean currents.
- 9.8** A hydraulic automobile lift is designed to lift cars with a maximum mass of 3000 kg. The area of cross-section of the piston carrying the load is  $425 \text{ cm}^2$ . What maximum pressure would the smaller piston have to bear?
- 9.9** A U-tube contains water and methylated spirit separated by mercury. The mercury columns in the two arms are in level with 10.0 cm of water in one arm and 12.5 cm of spirit in the other. What is the specific gravity of spirit?
- 9.10** In the previous problem, if 15.0 cm of water and spirit each are further poured into the respective arms of the tube, what is the difference in the levels of mercury in the two arms? (Specific gravity of mercury = 13.6)
- 9.11** Can Bernoulli's equation be used to describe the flow of water through a rapid in a river? Explain.
- 9.12** Does it matter if one uses gauge instead of absolute pressures in applying Bernoulli's equation? Explain.
- 9.13** Glycerine flows steadily through a horizontal tube of length 1.5 m and radius 1.0 cm. If the amount of glycerine collected per second at one end is  $4.0 \times 10^{-3} \text{ kg s}^{-1}$ , what is the pressure difference between the two ends of the tube? (Density of glycerine =  $1.3 \times 10^3 \text{ kg m}^{-3}$  and viscosity of glycerine =  $0.83 \text{ Pa s}$ ). [You may also like to check if the assumption of laminar flow in the tube is correct].
- 9.14** In a test experiment on a model aeroplane in a wind tunnel, the flow speeds on the upper and lower surfaces of the wing are  $70 \text{ m s}^{-1}$  and  $63 \text{ m s}^{-1}$  respectively. What is the lift on the wing if its area is  $2.5 \text{ m}^2$ ? Take the density of air to be  $1.3 \text{ kg m}^{-3}$ .
- 9.15** Figures 9.20(a) and (b) refer to the steady flow of a (non-viscous) liquid. Which of the two figures is incorrect? Why?

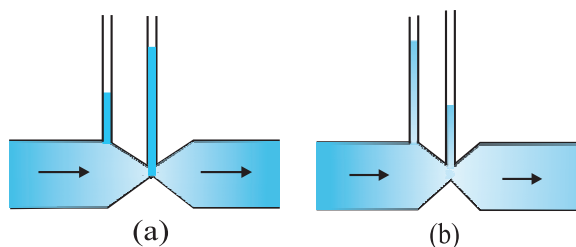

Fig. 9.20

- 9.16** The cylindrical tube of a spray pump has a cross-section of  $8.0 \text{ cm}^2$  one end of which has 40 fine holes each of diameter  $1.0 \text{ mm}$ . If the liquid flow inside the tube is  $1.5 \text{ m min}^{-1}$ , what is the speed of ejection of the liquid through the holes?
- 9.17** A U-shaped wire is dipped in a soap solution, and removed. The thin soap film formed between the wire and the light slider supports a weight of  $1.5 \times 10^{-2} \text{ N}$  (which includes the small weight of the slider). The length of the slider is  $30 \text{ cm}$ . What is the surface tension of the film?
- 9.18** Figure 9.21 (a) shows a thin liquid film supporting a small weight  $= 4.5 \times 10^{-2} \text{ N}$ . What is the weight supported by a film of the same liquid at the same temperature in Fig. (b) and (c)? Explain your answer physically.

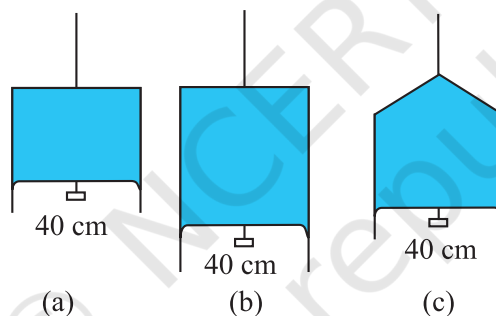

Fig. 9.21

- 9.19** What is the pressure inside the drop of mercury of radius  $3.00 \text{ mm}$  at room temperature? Surface tension of mercury at that temperature ( $20^\circ\text{C}$ ) is  $4.65 \times 10^{-1} \text{ N m}^{-1}$ . The atmospheric pressure is  $1.01 \times 10^5 \text{ Pa}$ . Also give the excess pressure inside the drop.
- 9.20** What is the excess pressure inside a bubble of soap solution of radius  $5.00 \text{ mm}$ , given that the surface tension of soap solution at the temperature ( $20^\circ\text{C}$ ) is  $2.50 \times 10^{-2} \text{ N m}^{-1}$ ? If an air bubble of the same dimension were formed at depth of  $40.0 \text{ cm}$  inside a container containing the soap solution (of relative density  $1.20$ ), what would be the pressure inside the bubble? (1 atmospheric pressure is  $1.01 \times 10^5 \text{ Pa}$ ).



11087CH11

## CHAPTER TEN

# THERMAL PROPERTIES OF MATTER

- 10.1** Introduction
- 10.2** Temperature and heat
- 10.3** Measurement of temperature
- 10.4** Ideal-gas equation and absolute temperature
- 10.5** Thermal expansion
- 10.6** Specific heat capacity
- 10.7** Calorimetry
- 10.8** Change of state
- 10.9** Heat transfer
- 10.10** Newton's law of cooling

Summary  
Points to ponder  
Exercises  
Additional Exercises

### 10.1 INTRODUCTION

We all have common sense notions of heat and temperature. Temperature is a measure of 'hotness' of a body. A kettle with boiling water is hotter than a box containing ice. In physics, we need to define the notion of heat, temperature, etc., more carefully. In this chapter, you will learn what heat is and how it is measured, and study the various processes by which heat flows from one body to another. Along the way, you will find out why blacksmiths heat the iron ring before fitting on the rim of a wooden wheel of a horse cart and why the wind at the beach often reverses direction after the sun goes down. You will also learn what happens when water boils or freezes, and its temperature does not change during these processes even though a great deal of heat is flowing into or out of it.

### 10.2 TEMPERATURE AND HEAT

We can begin studying thermal properties of matter with definitions of temperature and heat. Temperature is a relative measure, or indication of hotness or coldness. A hot utensil is said to have a high temperature, and ice cube to have a low temperature. An object that has a higher temperature than another object is said to be hotter. Note that hot and cold are relative terms, like tall and short. We can perceive temperature by touch. However, this temperature sense is somewhat unreliable and its range is too limited to be useful for scientific purposes.

We know from experience that a glass of ice-cold water left on a table on a hot summer day eventually warms up whereas a cup of hot tea on the same table cools down. It means that when the temperature of body, ice-cold water or hot tea in this case, and its surrounding medium are different, heat transfer takes place between the system and the surrounding medium, until the body and the surrounding medium are at the same temperature. We also know that in the case of glass tumbler of ice-cold water, heat flows from the environment to

the glass tumbler, whereas in the case of hot tea, it flows from the cup of hot tea to the environment. So, we can say that **heat is the form of energy transferred between two (or more) systems or a system and its surroundings by virtue of temperature difference.** The SI unit of heat energy transferred is expressed in joule (J) while SI unit of temperature is Kelvin (K), and degree Celsius ( $^{\circ}\text{C}$ ) is a commonly used unit of temperature. When an object is heated, many changes may take place. Its temperature may rise, it may expand or change state. We will study the effect of heat on different bodies in later sections.

### 10.3 MEASUREMENT OF TEMPERATURE

A measure of temperature is obtained using a thermometer. Many physical properties of materials change sufficiently with temperature. Some such properties are used as the basis for constructing thermometers. The commonly used property is variation of the volume of a liquid with temperature. For example, in common liquid-in-glass thermometers, mercury, alcohol etc., are used whose volume varies linearly with temperature over a wide range.

Thermometers are calibrated so that a numerical value may be assigned to a given temperature in an appropriate scale. For the definition of any standard scale, two fixed reference points are needed. Since all substances change dimensions with temperature, an absolute reference for expansion is not available. However, the necessary fixed points may be correlated to the physical phenomena that always occur at the same temperature. The ice point and the steam point of water are two convenient fixed points and are known as the freezing and boiling points, respectively. These two points are the temperatures at which pure water freezes and boils under standard pressure. The two familiar temperature scales are the Fahrenheit temperature scale and the Celsius temperature scale. The ice and steam point have values  $32^{\circ}\text{F}$  and  $212^{\circ}\text{F}$ , respectively, on the Fahrenheit scale and  $0^{\circ}\text{C}$  and  $100^{\circ}\text{C}$  on the Celsius scale. On the Fahrenheit scale, there are 180 equal intervals between two reference points, and on the Celsius scale, there are 100.

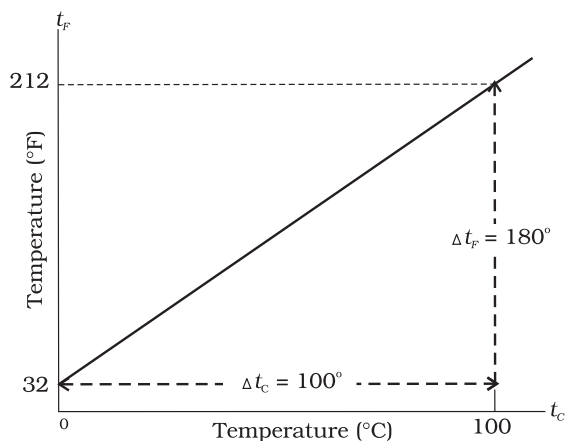

**Fig. 10.1** A plot of Fahrenheit temperature ( $t_f$ ) versus Celsius temperature ( $t_c$ ).

A relationship for converting between the two scales may be obtained from a graph of Fahrenheit temperature ( $t_f$ ) versus Celsius temperature ( $t_c$ ) in a straight line (Fig. 10.1), whose equation is

$$\frac{t_f - 32}{180} = \frac{t_c}{100} \quad (10.1)$$

### 10.4 IDEAL-GAS EQUATION AND ABSOLUTE TEMPERATURE

Liquid-in-glass thermometers show different readings for temperatures other than the fixed points because of differing expansion properties. A thermometer that uses a gas, however, gives the same readings regardless of which gas is used. Experiments show that all gases at low densities exhibit same expansion behaviour. The variables that describe the behaviour of a given quantity (mass) of gas are pressure, volume, and temperature ( $P$ ,  $V$ , and  $T$ ) (where  $T = t + 273.15$ ;  $t$  is the temperature in  $^{\circ}\text{C}$ ). When temperature is held constant, the pressure and volume of a quantity of gas are related as  $PV = \text{constant}$ . This relationship is known as Boyle's law, after Robert Boyle (1627–1691), the English Chemist who discovered it. When the pressure is held constant, the volume of a quantity of the gas is related to the temperature as  $V/T = \text{constant}$ . This relationship is known as Charles' law, after French scientist Jacques Charles (1747–1823). Low-density gases obey these laws, which may be combined into a single

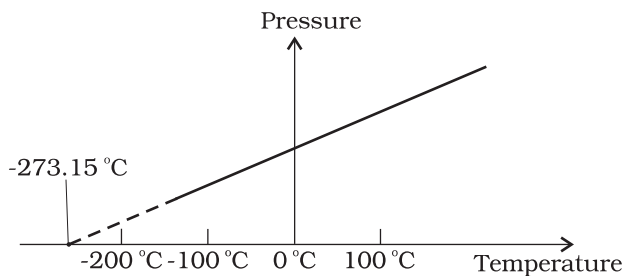

**Fig. 10.2** Pressure versus temperature of a low density gas kept at constant volume.

relationship. Notice that since  $PV = \text{constant}$  and  $V/T = \text{constant}$  for a given quantity of gas, then  $PV/T$  should also be a constant. This relationship is known as ideal gas law. It can be written in a more general form that applies not just to a given quantity of a single gas but to any quantity of any low-density gas and is known as **ideal-gas equation**:

$$\frac{PV}{T} = \mu R$$

$$\text{or } PV = \mu RT \quad (10.2)$$

where,  $\mu$  is the number of moles in the sample of gas and  $R$  is called universal gas constant:

$$R = 8.31 \text{ J mol}^{-1} \text{ K}^{-1}$$

In Eq. 10.2, we have learnt that the pressure and volume are directly proportional to temperature:  $PV \propto T$ . This relationship allows a gas to be used to measure temperature in a constant volume gas thermometer. Holding the volume of a gas constant, it gives  $P \propto T$ . Thus, with a constant-volume gas thermometer, temperature is read in terms of pressure. A plot of pressure versus temperature gives a straight line in this case, as shown in Fig. 10.2.

However, measurements on real gases deviate from the values predicted by the ideal gas law at low temperature. But the relationship is linear over a large temperature range, and it looks as though the pressure might reach zero with decreasing temperature if the gas continued to be a gas. The absolute minimum temperature for an ideal gas, therefore, inferred by extrapolating the straight line to the axis, as in Fig. 10.3. This temperature is found to be  $-273.15^\circ\text{C}$  and is designated as **absolute zero**. Absolute zero is the foundation of the Kelvin temperature scale or absolute scale temperature

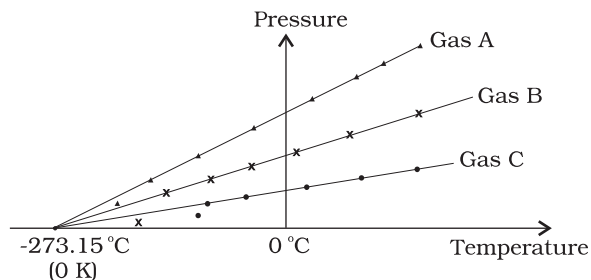

**Fig. 10.3** A plot of pressure versus temperature and extrapolation of lines for low density gases indicates the same absolute zero temperature.

named after the British scientist Lord Kelvin. On this scale,  $-273.15^\circ\text{C}$  is taken as the zero point, that is  $0 \text{ K}$  (Fig. 10.4).

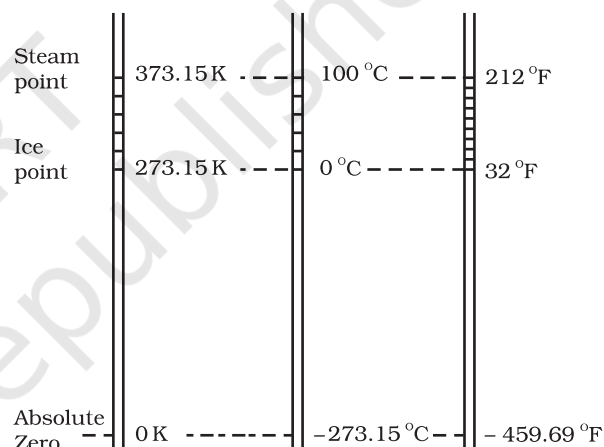

**Fig. 10.4** Comparison of the Kelvin, Celsius and Fahrenheit temperature scales.

The size of unit in Kelvin and Celsius temperature scales is the same. So, temperature on these scales are related by

$$T = t_c + 273.15 \quad (10.3)$$

## 10.5 THERMAL EXPANSION

You may have observed that sometimes sealed bottles with metallic lids are so tightly screwed that one has to put the lid in hot water for some time to open it. This would allow the metallic lid to expand, thereby loosening it to unscrew easily. In case of liquids, you may have observed that mercury in a thermometer rises, when the thermometer is put in slightly warm water. If we take out the thermometer from the warm

water the level of mercury falls again. Similarly, in case of gases, a balloon partially inflated in a cool room may expand to full size when placed in warm water. On the other hand, a fully inflated balloon when immersed in cold water would start shrinking due to contraction of the air inside.

It is our common experience that most substances expand on heating and contract on cooling. A change in the temperature of a body causes change in its dimensions. The increase in the dimensions of a body due to the increase in its temperature is called thermal expansion. The expansion in length is called **linear expansion**. The expansion in area is called **area expansion**. The expansion in volume is called **volume expansion** (Fig. 10.5).

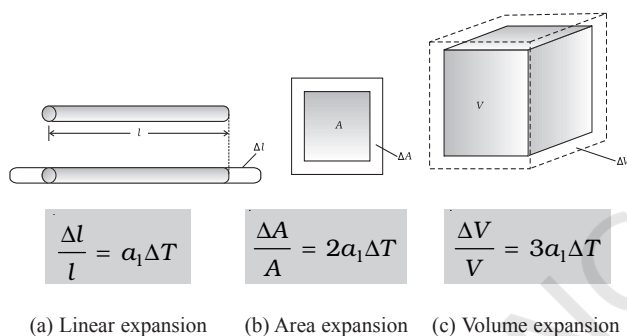

**Fig. 10.5** Thermal Expansion.

If the substance is in the form of a long rod, then for small change in temperature,  $\Delta T$ , the fractional change in length,  $\Delta l/l$ , is directly proportional to  $\Delta T$ .

$$\frac{\Delta l}{l} = \alpha_1 \Delta T \quad (10.4)$$

where  $\alpha_1$  is known as the **coefficient of linear expansion** (or linear expansivity) and is characteristic of the material of the rod. In Table 10.1, typical average values of the coefficient of linear expansion for some material in the temperature range  $0^\circ\text{C}$  to  $100^\circ\text{C}$  are given. From this Table, compare the value of  $\alpha_1$  for glass and copper. We find that copper expands about five times more than glass for the same rise in temperature. Normally, metals expand more and have relatively high values of  $\alpha_1$ .

**Table 10.1** Values of coefficient of linear expansion for some material

Material	$\alpha_1$ ( $10^{-5} \text{ K}^{-1}$ )
Aluminium	2.5
Brass	1.8
Iron	1.2
Copper	1.7
Silver	1.9
Gold	1.4
Glass (pyrex)	0.32
Lead	0.29

Similarly, we consider the fractional change in volume,  $\frac{\Delta V}{V}$ , of a substance for temperature change  $\Delta T$  and define the **coefficient of volume expansion (or volume expansivity)**,  $\alpha_v$  as

$$\alpha_v = \left( \frac{\Delta V}{V} \right) \frac{1}{\Delta T} \quad (10.5)$$

Here  $\alpha_v$  is also a characteristic of the substance but is not strictly a constant. It depends in general on temperature (Fig 10.6). It is seen that  $\alpha_v$  becomes constant only at a high temperature.

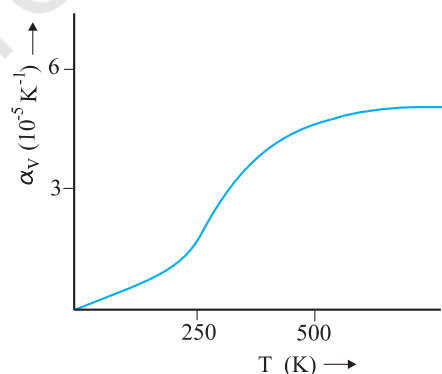

**Fig. 10.6** Coefficient of volume expansion of copper as a function of temperature.

Table 10.2 gives the values of coefficient of volume expansion of some common substances in the temperature range  $0$ – $100^\circ\text{C}$ . You can see that thermal expansion of these substances (solids and liquids) is rather small, with material,

like pyrex glass and invar (a special iron-nickel alloy) having particularly low values of  $\alpha_v$ . From this Table we find that the value of  $\alpha_v$  for alcohol (ethanol) is more than mercury and expands more than mercury for the same rise in temperature.

**Table 10.2** Values of coefficient of volume expansion for some substances

Material	$\alpha_v$ ( $\text{K}^{-1}$ )
Aluminium	$7 \times 10^{-5}$
Brass	$6 \times 10^{-5}$
Iron	$3.55 \times 10^{-5}$
Paraffin	$58.8 \times 10^{-5}$
Glass (ordinary)	$2.5 \times 10^{-5}$
Glass (pyrex)	$1 \times 10^{-5}$
Hard rubber	$2.4 \times 10^{-4}$
Invar	$2 \times 10^{-6}$
Mercury	$18.2 \times 10^{-5}$
Water	$20.7 \times 10^{-5}$
Alcohol (ethanol)	$110 \times 10^{-5}$

Water exhibits an anomalous behaviour; it contracts on heating between  $0^\circ\text{C}$  and  $4^\circ\text{C}$ . The volume of a given amount of water decreases as it is cooled from room temperature, until its temperature reaches  $4^\circ\text{C}$ , [Fig. 10.7(a)]. Below  $4^\circ\text{C}$ , the volume increases, and therefore, the density decreases [Fig. 10.7(b)].

This means that water has the maximum density at  $4^\circ\text{C}$ . This property has an important environmental effect: bodies of water, such as

lakes and ponds, freeze at the top first. As a lake cools toward  $4^\circ\text{C}$ , water near the surface loses energy to the atmosphere, becomes denser, and sinks; the warmer, less dense water near the bottom rises. However, once the colder water on top reaches temperature below  $4^\circ\text{C}$ , it becomes less dense and remains at the surface, where it freezes. If water did not have this property, lakes and ponds would freeze from the bottom up, which would destroy much of their animal and plant life.

Gases, at ordinary temperature, expand more than solids and liquids. For liquids, the coefficient of volume expansion is relatively independent of the temperature. However, for gases it is dependent on temperature. For an ideal gas, the coefficient of volume expansion at constant pressure can be found from the ideal gas equation:

$$PV = \mu RT$$

At constant pressure

$$P\Delta V = \mu R \Delta T$$

$$\frac{\Delta V}{V} = \frac{\Delta T}{T}$$

$$\text{i.e., } \alpha_v = \frac{1}{T} \text{ for ideal gas} \quad (10.6)$$

At  $0^\circ\text{C}$ ,  $\alpha_v = 3.7 \times 10^{-3} \text{ K}^{-1}$ , which is much larger than that for solids and liquids. Equation (10.6) shows the temperature dependence of  $\alpha_v$ ; it decreases with increasing temperature. For a gas at room temperature and constant pressure,  $\alpha_v$  is about  $3300 \times 10^{-6} \text{ K}^{-1}$ , as

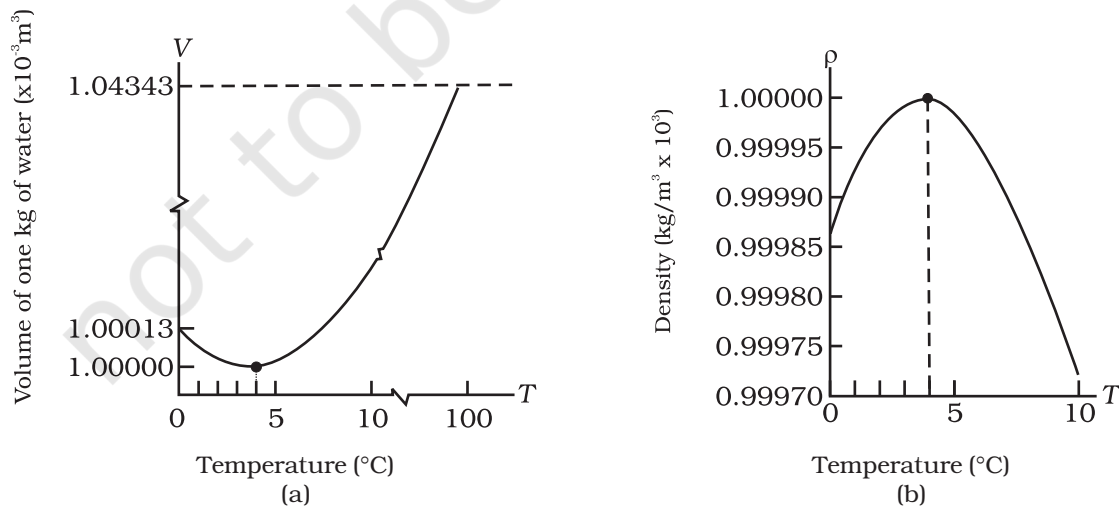

**Fig. 10.7** Thermal expansion of water.

much as order(s) of magnitude larger than the coefficient of volume expansion of typical liquids.

There is a simple relation between the coefficient of volume expansion ( $\alpha_v$ ) and coefficient of linear expansion ( $\alpha_l$ ). Imagine a cube of length,  $l$ , that expands equally in all directions, when its temperature increases by  $\Delta T$ . We have

$$\Delta l = \alpha_l l \Delta T$$

so,  $\Delta V = (l + \Delta l)^3 - l^3 \approx 3l^2 \Delta l$  (10.7)

In Equation (10.7), terms in  $(\Delta l)^2$  and  $(\Delta l)^3$  have been neglected since  $\Delta l$  is small compared to  $l$ . So

$$\Delta V = \frac{3V \Delta l}{l} = 3V \alpha_l \Delta T$$
 (10.8)

which gives

$$\alpha_v = 3\alpha_l$$
 (10.9)

What happens by preventing the thermal expansion of a rod by fixing its ends rigidly? Clearly, the rod acquires a compressive strain due to the external forces provided by the rigid support at the ends. The corresponding stress set up in the rod is called **thermal stress**. For example, consider a steel rail of length 5 m and area of cross-section 40 cm<sup>2</sup> that is prevented from expanding while the temperature rises by 10 °C. The coefficient of linear expansion of steel is  $\alpha_{l(\text{steel})} = 1.2 \times 10^{-5} \text{ K}^{-1}$ . Thus, the compressive

strain is  $\frac{\Delta l}{l} = \alpha_{l(\text{steel})} \Delta T = 1.2 \times 10^{-5} \times 10 = 1.2 \times 10^{-4}$ .

Young's modulus of steel is  $Y_{(\text{steel})} = 2 \times 10^{11} \text{ N m}^{-2}$ . Therefore, the thermal stress developed is

$$\frac{\Delta F}{A} = Y_{\text{steel}} \left( \frac{\Delta l}{l} \right) = 2.4 \times 10^7 \text{ N m}^{-2}, \text{ which}$$

corresponds to an external force of

$$\Delta F = A Y_{\text{steel}} \left( \frac{\Delta l}{l} \right) = 2.4 \times 10^7 \times 40 \times 10^{-4} \approx 10^5 \text{ N. If}$$

two such steel rails, fixed at their outer ends, are in contact at their inner ends, a force of this magnitude can easily bend the rails.

► **Example 10.1** Show that the coefficient of area expansion,  $(\Delta A/A)/\Delta T$ , of a rectangular sheet of the solid is twice its linear expansivity,  $\alpha_l$ .

**Answer**

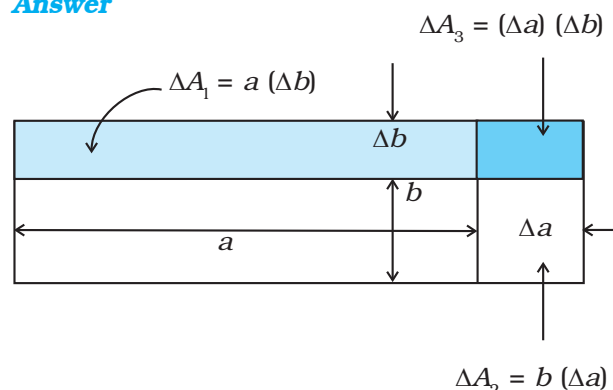

**Fig. 10.8**

Consider a rectangular sheet of the solid material of length  $a$  and breadth  $b$  (Fig. 10.8). When the temperature increases by  $\Delta T$ ,  $a$  increases by  $\Delta a = \alpha_l a \Delta T$  and  $b$  increases by  $\Delta b = \alpha_l b \Delta T$ . From Fig. 10.8, the increase in area

$$\begin{aligned} \Delta A &= \Delta A_1 + \Delta A_2 + \Delta A_3 \\ \Delta A &= a \Delta b + b \Delta a + (\Delta a)(\Delta b) \\ &= a \alpha_l b \Delta T + b \alpha_l a \Delta T + (\alpha_l)^2 ab (\Delta T)^2 \\ &= \alpha_l ab \Delta T (2 + \alpha_l \Delta T) = \alpha_l A \Delta T (2 + \alpha_l \Delta T) \end{aligned}$$

Since  $\alpha_l \approx 10^{-5} \text{ K}^{-1}$ , from Table 10.1, the product  $\alpha_l \Delta T$  for fractional temperature is small in comparison with 2 and may be neglected. Hence,

$$\left( \frac{\Delta A}{A} \right) \frac{1}{\Delta T} \approx 2\alpha_l$$

► **Example 10.2** A blacksmith fixes iron ring on the rim of the wooden wheel of a horse cart. The diameter of the rim and the iron ring are 5.243 m and 5.231 m, respectively at 27 °C. To what temperature should the ring be heated so as to fit the rim of the wheel?

**Answer**

Given,  $T_1 = 27 \text{ }^\circ\text{C}$   
 $L_{r1} = 5.231 \text{ m}$   
 $L_{r2} = 5.243 \text{ m}$

So,

$$\begin{aligned} L_{r2} &= L_{r1} [1 + \alpha_l (T_2 - T_1)] \\ 5.243 \text{ m} &= 5.231 \text{ m} [1 + 1.20 \times 10^{-5} \text{ K}^{-1} (T_2 - 27 \text{ }^\circ\text{C})] \\ \text{or } T_2 &= 218 \text{ }^\circ\text{C.} \end{aligned}$$



## 10.6 SPECIFIC HEAT CAPACITY

Take some water in a vessel and start heating it on a burner. Soon you will notice that bubbles begin to move upward. As the temperature is raised the motion of water particles increases till it becomes turbulent as water starts boiling. What are the factors on which the quantity of heat required to raise the temperature of a substance depend? In order to answer this question in the first step, heat a given quantity of water to raise its temperature by, say 20 °C and note the time taken. Again take the same amount of water and raise its temperature by 40 °C using the same source of heat. Note the time taken by using a stopwatch. You will find it takes about twice the time and therefore, double the quantity of heat required raising twice the temperature of same amount of water.

In the second step, now suppose you take double the amount of water and heat it, using the same heating arrangement, to raise the temperature by 20 °C, you will find the time taken is again twice that required in the first step.

In the third step, in place of water, now heat the same quantity of some oil, say mustard oil, and raise the temperature again by 20 °C. Now note the time by the same stopwatch. You will find the time taken will be shorter and therefore, the quantity of heat required would be less than that required by the same amount of water for the same rise in temperature.

The above observations show that the quantity of heat required to warm a given substance depends on its mass,  $m$ , the change in temperature,  $\Delta T$  and the nature of substance. The change in temperature of a substance, when a given quantity of heat is absorbed or rejected by it, is characterised by a quantity called the **heat capacity** of that substance. We define heat capacity,  $S$  of a substance as

$$S = \frac{\Delta Q}{\Delta T} \quad (10.10)$$

where  $\Delta Q$  is the amount of heat supplied to the substance to change its temperature from  $T$  to  $T + \Delta T$ .

You have observed that if equal amount of heat is added to equal masses of different substances, the resulting temperature changes will not be the same. It implies that every substance has a unique value for the amount of

heat absorbed or given off to change the temperature of unit mass of it by one unit. This quantity is referred to as the **specific heat capacity** of the substance.

If  $\Delta Q$  stands for the amount of heat absorbed or given off by a substance of mass  $m$  when it undergoes a temperature change  $\Delta T$ , then the specific heat capacity, of that substance is given by

$$s = \frac{S}{m} = \frac{1}{m} \frac{\Delta Q}{\Delta T} \quad (10.11)$$

The **specific heat capacity** is the property of the substance which determines the change in the temperature of the substance (undergoing no phase change) when a given quantity of heat is absorbed (or given off) by it. It is defined as the amount of heat per unit mass absorbed or given off by the substance to change its temperature by one unit. It depends on the nature of the substance and its temperature. The SI unit of specific heat capacity is  $\text{J kg}^{-1} \text{K}^{-1}$ .

If the amount of substance is specified in terms of moles  $\mu$ , instead of mass  $m$  in kg, we can define heat capacity per mole of the substance by

$$C = \frac{S}{\mu} = \frac{1}{\mu} \frac{\Delta Q}{\Delta T} \quad (10.12)$$

where  $C$  is known as **molar specific heat capacity** of the substance. Like  $S$ ,  $C$  also depends on the nature of the substance and its temperature. The SI unit of molar specific heat capacity is  $\text{J mol}^{-1} \text{K}^{-1}$ .

However, in connection with specific heat capacity of gases, additional conditions may be needed to define  $C$ . In this case, heat transfer can be achieved by keeping either pressure or volume constant. If the gas is held under constant pressure during the heat transfer, then it is called the **molar specific heat capacity at constant pressure** and is denoted by  $C_p$ . On the other hand, if the volume of the gas is maintained during the heat transfer, then the corresponding molar specific heat capacity is called **molar specific heat capacity at constant volume** and is denoted by  $C_v$ . For details see Chapter 11. Table 10.3 lists measured specific heat capacity of some substances at atmospheric pressure and ordinary temperature while Table 10.4 lists molar specific heat capacities of some gases. From Table 10.3 you can note that water

**Table 10.3** Specific heat capacity of some substances at room temperature and atmospheric pressure

Substance	Specific heat capacity (J kg <sup>-1</sup> K <sup>-1</sup> )	Substance	Specific heat capacity (J kg <sup>-1</sup> K <sup>-1</sup> )
Aluminium	900.0	Ice	2060
Carbon	506.5	Glass	840
Copper	386.4	Iron	450
Lead	127.7	Kerosene	2118
Silver	236.1	Edible oil	1965
Tungsten	134.4	Mercury	140
Water	4186.0		

has the highest specific heat capacity compared to other substances. For this reason water is also used as a coolant in automobile radiators, as well as, a heater in hot water bags. Owing to its high specific heat capacity, water warms up more slowly than land during summer, and consequently wind from the sea has a cooling effect. Now, you can tell why in desert areas, the earth surface warms up quickly during the day and cools quickly at night.

**Table 10.4** Molar specific heat capacities of some gases

Gas	$C_p$ (J mol <sup>-1</sup> K <sup>-1</sup> )	$C_v$ (J mol <sup>-1</sup> K <sup>-1</sup> )
He	20.8	12.5
H <sub>2</sub>	28.8	20.4
N <sub>2</sub>	29.1	20.8
O <sub>2</sub>	29.4	21.1
CO <sub>2</sub>	37.0	28.5

## 10.7 CALORIMETRY

A system is said to be isolated if no exchange or transfer of heat occurs between the system and its surroundings. When different parts of an isolated system are at different temperature, a quantity of heat transfers from the part at higher temperature to the part at lower temperature. The heat lost by the part at higher temperature is equal to the heat gained by the part at lower temperature.

Calorimetry means measurement of heat. When a body at higher temperature is brought in contact with another body at lower temperature, the heat lost by the hot body is

equal to the heat gained by the colder body, provided no heat is allowed to escape to the surroundings. A device in which heat measurement can be done is called a **calorimeter**. It consists of a metallic vessel and stirrer of the same material, like copper or aluminium. The vessel is kept inside a wooden jacket, which contains heat insulating material, like glass wool etc. The outer jacket acts as a heat shield and reduces the heat loss from the inner vessel. There is an opening in the outer jacket through which a mercury thermometer can be inserted into the calorimeter (Fig. 10.20). The following example provides a method by which the specific heat capacity of a given solid can be determined by using the principle, heat gained is equal to the heat lost.

► **Example 10.3** A sphere of 0.047 kg aluminium is placed for sufficient time in a vessel containing boiling water, so that the sphere is at 100 °C. It is then immediately transferred to 0.14 kg copper calorimeter containing 0.25 kg water at 20 °C. The temperature of water rises and attains a steady state at 23 °C. Calculate the specific heat capacity of aluminium.

**Answer** In solving this example, we shall use the fact that at a steady state, heat given by an aluminium sphere will be equal to the heat absorbed by the water and calorimeter.

Mass of aluminium sphere ( $m_1$ ) = 0.047 kg  
 Initial temperature of aluminium sphere = 100 °C  
 Final temperature = 23 °C  
 Change in temperature ( $\Delta T$ ) = (100 °C - 23 °C) = 77 °C  
 Let specific heat capacity of aluminium be  $s_{Al}$ .

The amount of heat lost by the aluminium sphere =  $m_1 s_{Al} \Delta T = 0.047 \text{ kg} \times s_{Al} \times 77^\circ \text{C}$

Mass of water ( $m_2$ ) = 0.25 kg

Mass of calorimeter ( $m_3$ ) = 0.14 kg

Initial temperature of water and calorimeter =  $20^\circ \text{C}$

Final temperature of the mixture =  $23^\circ \text{C}$

Change in temperature ( $\Delta T_2$ ) =  $23^\circ \text{C} - 20^\circ \text{C} = 3^\circ \text{C}$

Specific heat capacity of water ( $s_w$ )  
=  $4.18 \times 10^3 \text{ J kg}^{-1} \text{ K}^{-1}$

Specific heat capacity of copper calorimeter  
=  $0.386 \times 10^3 \text{ J kg}^{-1} \text{ K}^{-1}$

The amount of heat gained by water and calorimeter =  $m_2 s_w \Delta T_2 + m_3 s_{cu} \Delta T_2$

=  $(m_2 s_w + m_3 s_{cu}) (\Delta T_2)$

=  $(0.25 \text{ kg} \times 4.18 \times 10^3 \text{ J kg}^{-1} \text{ K}^{-1} + 0.14 \text{ kg} \times 0.386 \times 10^3 \text{ J kg}^{-1} \text{ K}^{-1}) (23^\circ \text{C} - 20^\circ \text{C})$

In the steady state heat lost by the aluminium sphere = heat gained by water + heat gained by calorimeter.

So,  $0.047 \text{ kg} \times s_{Al} \times 77^\circ \text{C}$

=  $(0.25 \text{ kg} \times 4.18 \times 10^3 \text{ J kg}^{-1} \text{ K}^{-1} + 0.14 \text{ kg} \times 0.386 \times 10^3 \text{ J kg}^{-1} \text{ K}^{-1}) (3^\circ \text{C})$

$s_{Al} = 0.911 \text{ kJ kg}^{-1} \text{ K}^{-1}$

## 10.8 CHANGE OF STATE

Matter normally exists in three states: solid, liquid and gas. A transition from one of these states to another is called a change of state. Two common changes of states are solid to liquid and liquid to gas (and, vice versa). These changes can occur when the exchange of heat takes place between the substance and its surroundings. To study the change of state on heating or cooling, let us perform the following activity.

Take some cubes of ice in a beaker. Note the temperature of ice. Start heating it slowly on a constant heat source. Note the temperature after every minute. Continuously stir the mixture of water and ice. Draw a graph between temperature and time (Fig. 10.9). You will observe no change in the temperature as long as there is ice in the beaker. In the above process, the temperature of the system does not change even though heat is being continuously supplied. The heat supplied is being utilised in changing the state from solid (ice) to liquid (water).

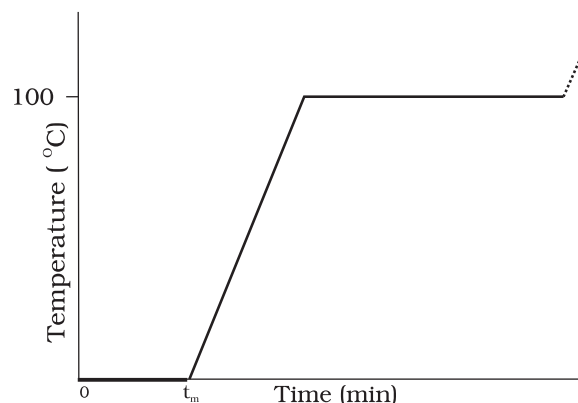

**Fig. 10.9** A plot of temperature versus time showing the changes in the state of ice on heating (not to scale).

The change of state from solid to liquid is called **melting** or fusion and from liquid to solid is called **freezing**. It is observed that the temperature remains constant until the entire amount of the solid substance melts. That is, **both the solid and the liquid states of the substance coexist in thermal equilibrium during the change of states from solid to liquid**. The temperature at which the solid and the liquid states of the substance is in thermal equilibrium with each other is called its **melting point**. It is characteristic of the substance. It also depends on pressure. The melting point of a substance at standard atmospheric pressure is called its **normal melting point**. Let us do the following activity to understand the process of melting of ice.

Take a slab of ice. Take a metallic wire and fix two blocks, say 5 kg each, at its ends. Put the wire over the slab as shown in Fig. 10.10. You will observe that the wire passes through the ice slab. This happens due to the fact that just below the wire, ice melts at lower temperature due to increase in pressure. When the wire has passed, water above the wire freezes again. Thus, the wire passes through the slab and the slab does not split. This phenomenon of refreezing is called **regelation**. Skating is possible on snow due to the formation of water under the skates. Water is formed due to the increase of pressure and it acts as a lubricant.

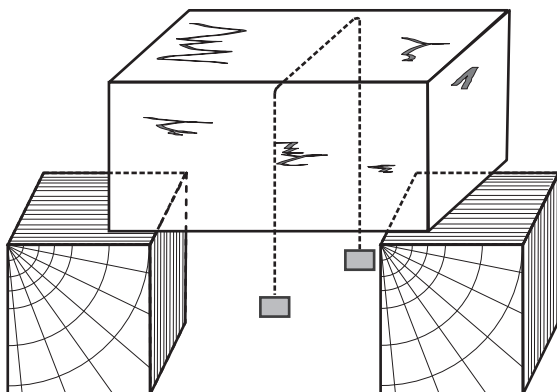

**Fig. 10.10**

After the whole of ice gets converted into water and as we continue further heating, we shall see that temperature begins to rise (Fig.10.9). The temperature keeps on rising till it reaches nearly

100 °C when it again becomes steady. The heat supplied is now being utilised to change water from liquid state to vapour or gaseous state.

The change of state from liquid to vapour (or gas) is called **vaporisation**. It is observed that the temperature remains constant until the entire amount of the liquid is converted into vapour. That is, both the liquid and vapour states of the substance coexist in thermal equilibrium, during the change of state from liquid to vapour. The temperature at which the liquid and the vapour states of the substance coexist is called its **boiling point**. Let us do the following activity to understand the process of boiling of water.

Take a round-bottom flask, more than half filled with water. Keep it over a burner and fix a

### Triple Point

The temperature of a substance remains constant during its change of state (phase change). A graph between the temperature  $T$  and the Pressure  $P$  of the substance is called a phase diagram or  $P-T$  diagram. The following figure shows the phase diagram of water and  $\text{CO}_2$ . Such a phase diagram divides the  $P-T$  plane into a solid-region, the vapour-region and the liquid-region. The regions are separated by the curves such as sublimation curve (BO), **fusion curve** (AO) and **vaporisation curve** (CO). The points on **sublimation curve** represent states in which solid and vapour phases coexist. The point on the sublimation curve BO represent states in which the solid and vapour phases co-exist. Points on the fusion curve AO represent states in which solid and liquid phase coexist. Points on the vapourisation curve CO represent states in which the liquid and vapour phases coexist. The temperature and pressure at which the fusion curve, the vaporisation curve and the sublimation curve meet and all the three phases of a substance coexist is called the **triple point** of the substance. For example the triple point of water is represented by the temperature 273.16 K and pressure  $6.11 \times 10^{-3}$  Pa.

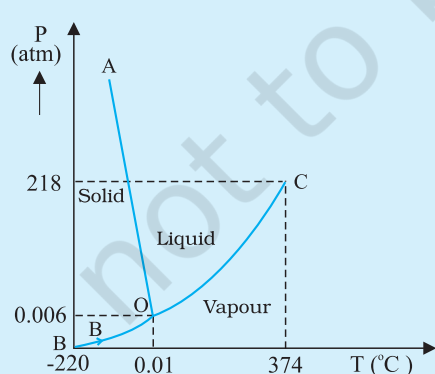

(a)

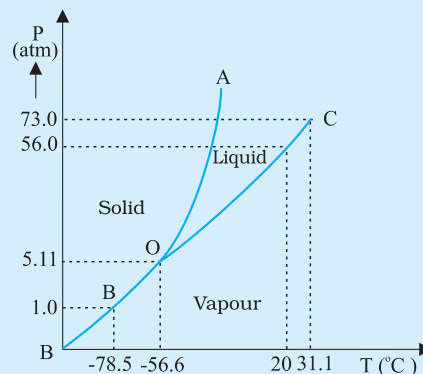

(b)

**Figure :** Pressure-temperature phase diagrams for (a) water and (b)  $\text{CO}_2$  (not to the scale).

thermometer and steam outlet through the cork of the flask (Fig. 10.11). As water gets heated in the flask, note first that the air, which was dissolved in the water, will come out as small bubbles. Later, bubbles of steam will form at the bottom but as they rise to the cooler water near the top, they condense and disappear. Finally, as the temperature of the entire mass of the water reaches  $100\text{ }^{\circ}\text{C}$ , bubbles of steam reach the surface and boiling is said to occur. The steam in the flask may not be visible but as it comes out of the flask, it condenses as tiny droplets of water, giving a foggy appearance.

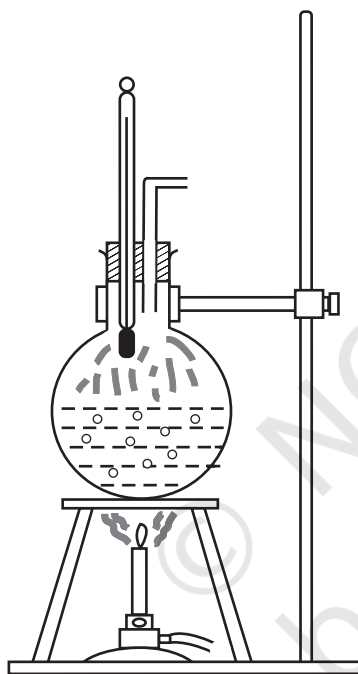

**Fig. 10.11** Boiling process.

If now the steam outlet is closed for a few seconds to increase the pressure in the flask, you will notice that boiling stops. More heat would be required to raise the temperature (depending on the increase in pressure) before boiling begins again. Thus boiling point increases with increase in pressure.

Let us now remove the burner. Allow water to cool to about  $80\text{ }^{\circ}\text{C}$ . Remove the thermometer and steam outlet. Close the flask with the airtight

cork. Keep the flask turned upside down on the stand. Pour ice-cold water on the flask. Water vapours in the flask condense reducing the pressure on the water surface inside the flask. Water begins to boil again, now at a lower temperature. Thus boiling point decreases with decrease in pressure.

This explains why cooking is difficult on hills. At high altitudes, atmospheric pressure is lower, reducing the boiling point of water as compared to that at sea level. On the other hand, boiling point is increased inside a pressure cooker by increasing the pressure. Hence cooking is faster. The boiling point of a substance at standard atmospheric pressure is called its **normal boiling point**.

However, all substances do not pass through the three states: solid-liquid-gas. There are certain substances which normally pass from the solid to the vapour state directly and vice versa. The change from solid state to vapour state without passing through the liquid state is called **sublimation**, and the substance is said to sublime. Dry ice (solid  $\text{CO}_2$ ) sublimates, so also iodine. During the sublimation process both the solid and vapour states of a substance coexist in thermal equilibrium.

### 10.8.1 Latent Heat

In Section 10.8, we have learnt that certain amount of heat energy is transferred between a substance and its surroundings when it undergoes a change of state. The amount of heat per unit mass transferred during change of state of the substance is called latent heat of the substance for the process. For example, if heat is added to a given quantity of ice at  $-10\text{ }^{\circ}\text{C}$ , the temperature of ice increases until it reaches its melting point ( $0\text{ }^{\circ}\text{C}$ ). At this temperature, the addition of more heat does not increase the temperature but causes the ice to melt, or changes its state. Once the entire ice melts, adding more heat will cause the temperature of the water to rise. A similar situation occurs during liquid gas change of state at the boiling point. Adding more heat to boiling water causes vaporisation, without increase in temperature.

**Table 10.5** Temperatures of the change of state and latent heats for various substances at 1 atm pressure

Substance	Melting Point (°C)	$L_f$ ( $10^5 \text{ J kg}^{-1}$ )	Boiling Point (°C)	$L_v$ ( $10^5 \text{ J kg}^{-1}$ )
Ethanol	-114	1.0	78	8.5
Gold	1063	0.645	2660	15.8
Lead	328	0.25	1744	8.67
Mercury	-39	0.12	357	2.7
Nitrogen	-210	0.26	-196	2.0
Oxygen	-219	0.14	-183	2.1
Water	0	3.33	100	22.6

The heat required during a change of state depends upon the heat of transformation and the mass of the substance undergoing a change of state. Thus, if mass  $m$  of a substance undergoes a change from one state to the other, then the quantity of heat required is given by

$$Q = mL \quad \text{or} \quad L = Q/m \quad (10.13)$$

where  $L$  is known as latent heat and is a characteristic of the substance. Its SI unit is  $\text{J kg}^{-1}$ . The value of  $L$  also depends on the pressure. Its value is usually quoted at standard atmospheric pressure. The latent heat for a solid-liquid state change is called the **latent heat of fusion** ( $L_f$ ), and that for a liquid-gas state change is called the **latent heat of vaporisation** ( $L_v$ ). These are often referred to as the heat of fusion and the heat of vaporisation. A plot of temperature versus heat for a quantity of water is shown in Fig. 10.12. The latent heats of some substances, their freezing and boiling points, are given in Table 10.5.

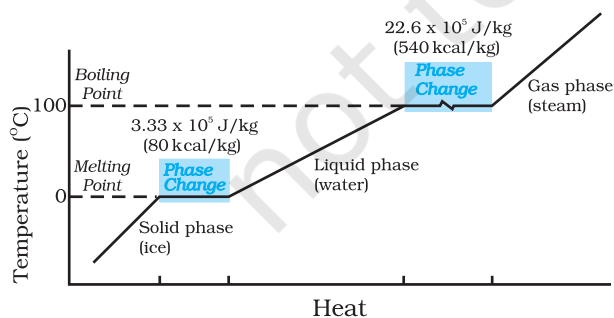
**Fig. 10.12** Temperature versus heat for water at 1 atm pressure (not to scale).

Note that when heat is added (or removed) during a change of state, the temperature remains constant. Note in Fig. 10.12 that the slopes of the phase lines are not all the same, which indicate that specific heats of the various states are not equal. For water, the latent heat of fusion and vaporisation are  $L_f = 3.33 \times 10^5 \text{ J kg}^{-1}$  and  $L_v = 22.6 \times 10^5 \text{ J kg}^{-1}$ , respectively. That is,  $3.33 \times 10^5 \text{ J}$  of heat is needed to melt 1 kg ice at  $0^\circ\text{C}$ , and  $22.6 \times 10^5 \text{ J}$  of heat is needed to convert 1 kg water into steam at  $100^\circ\text{C}$ . So, steam at  $100^\circ\text{C}$  carries  $22.6 \times 10^5 \text{ J kg}^{-1}$  more heat than water at  $100^\circ\text{C}$ . This is why burns from steam are usually more serious than those from boiling water.

► **Example 10.4** When 0.15 kg of ice at  $0^\circ\text{C}$  is mixed with 0.30 kg of water at  $50^\circ\text{C}$  in a container, the resulting temperature is  $6.7^\circ\text{C}$ . Calculate the heat of fusion of ice. ( $s_{\text{water}} = 4186 \text{ J kg}^{-1} \text{ K}^{-1}$ )

**Answer**

$$\begin{aligned} \text{Heat lost by water} &= ms_w (\theta_f - \theta)_w \\ &= (0.30 \text{ kg}) (4186 \text{ J kg}^{-1} \text{ K}^{-1}) (50.0^\circ\text{C} - 6.7^\circ\text{C}) \\ &= 54376.14 \text{ J} \\ \text{Heat required to melt ice} &= m_2 L_f = (0.15 \text{ kg}) L_f \\ \text{Heat required to raise temperature of ice} \\ \text{water to final temperature} &= m_1 s_w (\theta_f - \theta)_1 \\ &= (0.15 \text{ kg}) (4186 \text{ J kg}^{-1} \text{ K}^{-1}) (6.7^\circ\text{C} - 0^\circ\text{C}) \\ &= 4206.93 \text{ J} \\ \text{Heat lost} &= \text{heat gained} \\ 54376.14 \text{ J} &= (0.15 \text{ kg}) L_f + 4206.93 \text{ J} \\ L_f &= 3.34 \times 10^5 \text{ J kg}^{-1}. \end{aligned}$$

► **Example 10.5** Calculate the heat required to convert 3 kg of ice at  $-12^\circ\text{C}$  kept in a calorimeter to steam at  $100^\circ\text{C}$  at atmospheric pressure. Given specific heat capacity of ice =  $2100\text{ J kg}^{-1}\text{ K}^{-1}$ , specific heat capacity of water =  $4186\text{ J kg}^{-1}\text{ K}^{-1}$ , latent heat of fusion of ice =  $3.35 \times 10^5\text{ J kg}^{-1}$  and latent heat of steam =  $2.256 \times 10^6\text{ J kg}^{-1}$ .

**Answer** We have

Mass of the ice,  $m = 3\text{ kg}$

specific heat capacity of ice,  $s_{\text{ice}}$   
 $= 2100\text{ J kg}^{-1}\text{ K}^{-1}$

specific heat capacity of water,  $s_{\text{water}}$   
 $= 4186\text{ J kg}^{-1}\text{ K}^{-1}$

latent heat of fusion of ice,  $L_{\text{fice}}$   
 $= 3.35 \times 10^5\text{ J kg}^{-1}$

latent heat of steam,  $L_{\text{steam}}$   
 $= 2.256 \times 10^6\text{ J kg}^{-1}$

Now,  $Q$  = heat required to convert 3 kg of ice at  $-12^\circ\text{C}$  to steam at  $100^\circ\text{C}$ ,

$Q_1$  = heat required to convert ice at  $-12^\circ\text{C}$  to ice at  $0^\circ\text{C}$ .  
 $= m s_{\text{ice}} \Delta T_1 = (3\text{ kg})(2100\text{ J kg}^{-1}\text{ K}^{-1}) [0 - (-12)]^\circ\text{C} = 75600\text{ J}$

$Q_2$  = heat required to melt ice at  $0^\circ\text{C}$  to water at  $0^\circ\text{C}$   
 $= m L_{\text{fice}} = (3\text{ kg})(3.35 \times 10^5\text{ J kg}^{-1})$   
 $= 1005000\text{ J}$

$Q_3$  = heat required to convert water at  $0^\circ\text{C}$  to water at  $100^\circ\text{C}$ .  
 $= m s_w \Delta T_2 = (3\text{ kg})(4186\text{ J kg}^{-1}\text{ K}^{-1}) (100^\circ\text{C})$   
 $= 1255800\text{ J}$

$Q_4$  = heat required to convert water at  $100^\circ\text{C}$  to steam at  $100^\circ\text{C}$ .  
 $= m L_{\text{steam}} = (3\text{ kg})(2.256 \times 10^6\text{ J kg}^{-1})$   
 $= 6768000\text{ J}$

So,  $Q = Q_1 + Q_2 + Q_3 + Q_4$   
 $= 75600\text{ J} + 1005000\text{ J}$   
 $+ 1255800\text{ J} + 6768000\text{ J}$   
 $= 9.1 \times 10^6\text{ J}$  ◀

## 10.9 HEAT TRANSFER

We have seen that heat is energy transfer from one system to another or from one part of a system to another part, arising due to

temperature difference. What are the different ways by which this energy transfer takes place? There are three distinct modes of heat transfer: conduction, convection and radiation (Fig. 10.13).

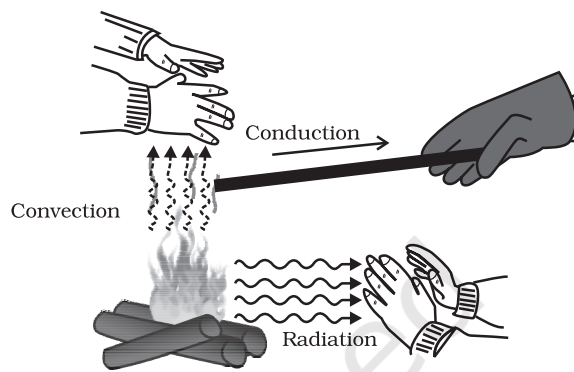

**Fig. 10.13** Heating by conduction, convection and radiation.

### 10.9.1 Conduction

Conduction is the mechanism of transfer of heat between two adjacent parts of a body because of their temperature difference. Suppose, one end of a metallic rod is put in a flame, the other end of the rod will soon be so hot that you cannot hold it by your bare hands. Here, heat transfer takes place by conduction from the hot end of the rod through its different parts to the other end. Gases are poor thermal conductors, while liquids have conductivities intermediate between solids and gases.

Heat conduction may be described quantitatively as the time rate of heat flow in a material for a given temperature difference. Consider a metallic bar of length  $L$  and uniform cross-section  $A$  with its two ends maintained at different temperatures. This can be done, for example, by putting the ends in thermal contact with large reservoirs at temperatures, say,  $T_c$  and  $T_d$ , respectively (Fig. 10.14). Let us assume the ideal condition that the sides of the bar are fully insulated so that no heat is exchanged between the sides and the surroundings.

After sometime, a steady state is reached; the temperature of the bar decreases uniformly with distance from  $T_c$  to  $T_d$ ; ( $T_c > T_d$ ). The reservoir at C supplies heat at a constant rate, which transfers through the bar and is given out at the same rate to the reservoir at D. It is found

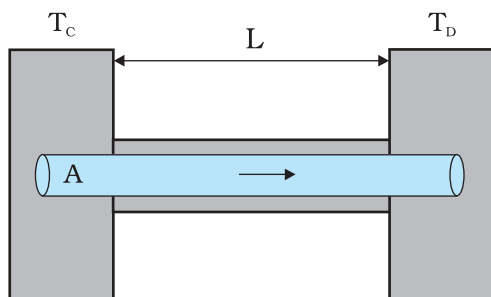

**Fig. 10.14** Steady state heat flow by conduction in a bar with its two ends maintained at temperatures  $T_c$  and  $T_d$ ; ( $T_c > T_d$ ).

experimentally that in this steady state, the rate of flow of heat (or heat current)  $H$  is proportional to the temperature difference ( $T_c - T_d$ ) and the area of cross-section  $A$  and is inversely proportional to the length  $L$  :

$$H = KA \frac{T_c - T_d}{L} \quad (10.14)$$

The constant of proportionality  $K$  is called the **thermal conductivity** of the material. The greater the value of  $K$  for a material, the more rapidly will it conduct heat. The SI unit of  $K$  is  $\text{J s}^{-1} \text{m}^{-1} \text{K}^{-1}$  or  $\text{W m}^{-1} \text{K}^{-1}$ . The thermal conductivities of various substances are listed in Table 10.6. These values vary slightly with temperature, but can be considered to be constant over a normal temperature range.

Compare the relatively large thermal conductivities of good thermal conductors and, metals, with the relatively small thermal conductivities of some good thermal insulators, such as wood and glass wool. You may have noticed that some cooking pots have copper coating on the bottom. Being a good conductor of heat, copper promotes the distribution of heat over the bottom of a pot for uniform cooking. Plastic foams, on the other hand, are good insulators, mainly because they contain pockets of air. Recall that gases are poor conductors, and note the low thermal conductivity of air in the Table 10.5. Heat retention and transfer are important in many other applications. Houses made of concrete roofs get very hot during summer days because thermal conductivity of concrete (though much smaller than that of a metal) is still not small enough. Therefore, people, usually, prefer to give a layer of earth or foam insulation on the ceiling so that heat transfer is

prohibited and keeps the room cooler. In some situations, heat transfer is critical. In a nuclear reactor, for example, elaborate heat transfer systems need to be installed so that the enormous energy produced by nuclear fission in the core transits out sufficiently fast, thus preventing the core from overheating.

**Table 10.6** Thermal conductivities of some material

Material	Thermal conductivity ( $\text{J s}^{-1} \text{m}^{-1} \text{K}^{-1}$ )
<b>Metals</b>	
Silver	406
Copper	385
Aluminium	205
Brass	109
Steel	50.2
Lead	34.7
Mercury	8.3
<b>Non-metals</b>	
Insulating brick	0.15
Concrete	0.8
Body fat	0.20
Felt	0.04
Glass	0.8
Ice	1.6
Glass wool	0.04
Wood	0.12
Water	0.8
<b>Gases</b>	
Air	0.024
Argon	0.016
Hydrogen	0.14

► **Example 10.6** What is the temperature of the steel-copper junction in the steady state of the system shown in Fig. 10.15. Length of the steel rod = 15.0 cm, length of the copper rod = 10.0 cm, temperature of the furnace = 300 °C, temperature of the other end = 0 °C. The area of cross section of the steel rod is twice that of the copper rod. (Thermal conductivity of steel =  $50.2 \text{ J s}^{-1} \text{m}^{-1} \text{K}^{-1}$ ; and of copper =  $385 \text{ J s}^{-1} \text{m}^{-1} \text{K}^{-1}$ ).



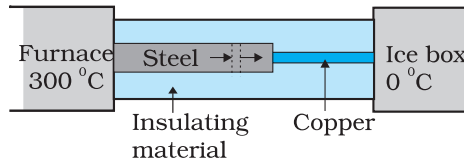

Fig. 10.15

**Answer** The insulating material around the rods reduces heat loss from the sides of the rods. Therefore, heat flows only along the length of the rods. Consider any cross section of the rod. In the steady state, heat flowing into the element must equal the heat flowing out of it; otherwise there would be a net gain or loss of heat by the element and its temperature would not be steady. Thus in the steady state, rate of heat flowing across a cross section of the rod is the same at every point along the length of the combined steel-copper rod. Let  $T$  be the temperature of the steel-copper junction in the steady state. Then,

$$\frac{K_1 A_1 (300 - T)}{L_1} = \frac{K_2 A_2 (T - 0)}{L_2}$$

where 1 and 2 refer to the steel and copper rod respectively. For  $A_1 = 2 A_2$ ,  $L_1 = 15.0$  cm,  $L_2 = 10.0$  cm,  $K_1 = 50.2$  J s<sup>-1</sup> m<sup>-1</sup> K<sup>-1</sup>,  $K_2 = 385$  J s<sup>-1</sup> m<sup>-1</sup> K<sup>-1</sup>, we have

$$\frac{50.2 \times 2 (300 - T)}{15} = \frac{385 T}{10}$$

which gives  $T = 44.4^\circ\text{C}$

**Example 10.7** An iron bar ( $L_1 = 0.1$  m,  $A_1 = 0.02$  m<sup>2</sup>,  $K_1 = 79$  W m<sup>-1</sup> K<sup>-1</sup>) and a brass bar ( $L_2 = 0.1$  m,  $A_2 = 0.02$  m<sup>2</sup>,  $K_2 = 109$  W m<sup>-1</sup> K<sup>-1</sup>) are soldered end to end as shown in Fig. 10.16. The free ends of the iron bar and brass bar are maintained at 373 K and 273 K respectively. Obtain expressions for and hence compute (i) the temperature of the junction of the two bars, (ii) the equivalent thermal conductivity of the compound bar, and (iii) the heat current through the compound bar.

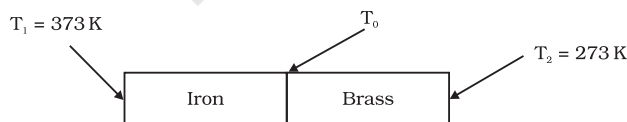

Fig 10.16

**Answer**

Given,  $L_1 = L_2 = L = 0.1$  m,  $A_1 = A_2 = A = 0.02$  m<sup>2</sup>,  $K_1 = 79$  W m<sup>-1</sup> K<sup>-1</sup>,  $K_2 = 109$  W m<sup>-1</sup> K<sup>-1</sup>,  $T_1 = 373$  K, and  $T_2 = 273$  K.

Under steady state condition, the heat current ( $H_1$ ) through iron bar is equal to the heat current ( $H_2$ ) through brass bar.

$$\text{So, } H = H_1 = H_2$$

$$= \frac{K_1 A_1 (T_1 - T_0)}{L_1} = \frac{K_2 A_2 (T_0 - T_2)}{L_2}$$

For  $A_1 = A_2 = A$  and  $L_1 = L_2 = L$ , this equation leads to

$$K_1 (T_1 - T_0) = K_2 (T_0 - T_2)$$

Thus, the junction temperature  $T_0$  of the two bars is

$$T_0 = \frac{(K_1 T_1 + K_2 T_2)}{(K_1 + K_2)}$$

Using this equation, the heat current  $H$  through either bar is

$$H = \frac{K_1 A (T_1 - T_0)}{L} = \frac{K_2 A (T_0 - T_2)}{L}$$

$$= \left( \frac{K_1 K_2}{K_1 + K_2} \right) \frac{A (T_1 - T_0)}{L} = \frac{A (T_1 - T_2)}{L \left( \frac{1}{K_1} + \frac{1}{K_2} \right)}$$

Using these equations, the heat current  $H'$  through the compound bar of length  $L_1 + L_2 = 2L$  and the equivalent thermal conductivity  $K'$ , of the compound bar are given by

$$H' = \frac{K' A (T_1 - T_2)}{2L} = H$$

$$K' = \frac{2 K_1 K_2}{K_1 + K_2}$$

$$(i) T_0 = \frac{(K_1 T_1 + K_2 T_2)}{(K_1 + K_2)}$$

$$= \frac{(79 \text{ W m}^{-1} \text{ K}^{-1})(373 \text{ K}) + (109 \text{ W m}^{-1} \text{ K}^{-1})(273 \text{ K})}{79 \text{ W m}^{-1} \text{ K}^{-1} + 109 \text{ W m}^{-1} \text{ K}^{-1}}$$

$$= 315 \text{ K}$$

$$(ii) K' = \frac{2 K_1 K_2}{K_1 + K_2}$$

$$= \frac{2 \times (79 \text{ W m}^{-1} \text{ K}^{-1}) \times (109 \text{ W m}^{-1} \text{ K}^{-1})}{79 \text{ W m}^{-1} \text{ K}^{-1} + 109 \text{ W m}^{-1} \text{ K}^{-1}}$$

$$= 91.6 \text{ W m}^{-1} \text{ K}^{-1}$$

$$\begin{aligned}
 \text{(iii) } H' = H &= \frac{K' A (T_1 - T_2)}{2 L} \\
 &= \frac{(91.6 \text{ W m}^{-1} \text{ K}^{-1}) \times (0.02 \text{ m}^2) \times (373 \text{ K} - 273 \text{ K})}{2 \times (0.1 \text{ m})} \\
 &= 916.1 \text{ W}
 \end{aligned}$$

### 10.9.2 Convection

Convection is a mode of heat transfer by actual motion of matter. It is possible only in fluids. Convection can be natural or forced. In natural convection, gravity plays an important part. When a fluid is heated from below, the hot part expands and, therefore, becomes less dense. Because of buoyancy, it rises and the upper colder part replaces it. This again gets heated, rises up and is replaced by the relatively colder part of the fluid. The process goes on. This mode of heat transfer is evidently different from conduction. Convection involves bulk transport of different parts of the fluid.

In forced convection, material is forced to move by a pump or by some other physical means. The common examples of forced convection systems are forced-air heating systems in home, the human circulatory system, and the cooling system of an automobile engine. In the human body, the heart acts as the pump that circulates blood through different parts of the body, transferring heat by forced convection and maintaining it at a uniform temperature.

Natural convection is responsible for many familiar phenomena. During the day, the ground heats up more quickly than large bodies

of water do. This occurs both because water has a greater specific heat capacity and because mixing currents disperse the absorbed heat throughout the great volume of water. The air in contact with the warm ground is heated by conduction. It expands, becoming less dense than the surrounding cooler air. As a result, the warm air rises (air currents) and the other air moves (winds) to fill the space-creating a sea breeze near a large body of water. Cooler air descends, and a thermal convection cycle is set up, which transfers heat away from the land. At night, the ground loses its heat more quickly, and the water surface is warmer than the land. As a result, the cycle is reversed (Fig. 10.17).

The other example of natural convection is the steady surface wind on the earth blowing in from north-east towards the equator, the so-called trade wind. A reasonable explanation is as follows: the equatorial and polar regions of the earth receive unequal solar heat. Air at the earth's surface near the equator is hot, while the air in the upper atmosphere of the poles is cool. In the absence of any other factor, a convection current would be set up, with the air at the equatorial surface rising and moving out towards the poles, descending and streaming in towards the equator. The rotation of the earth, however, modifies this convection current. Because of this, air close to the equator has an eastward speed of 1600 km/h, while it is zero close to the poles. As a result, the air descends not at the poles but at 30° N (North) latitude and returns to the equator. This is called **trade wind**.

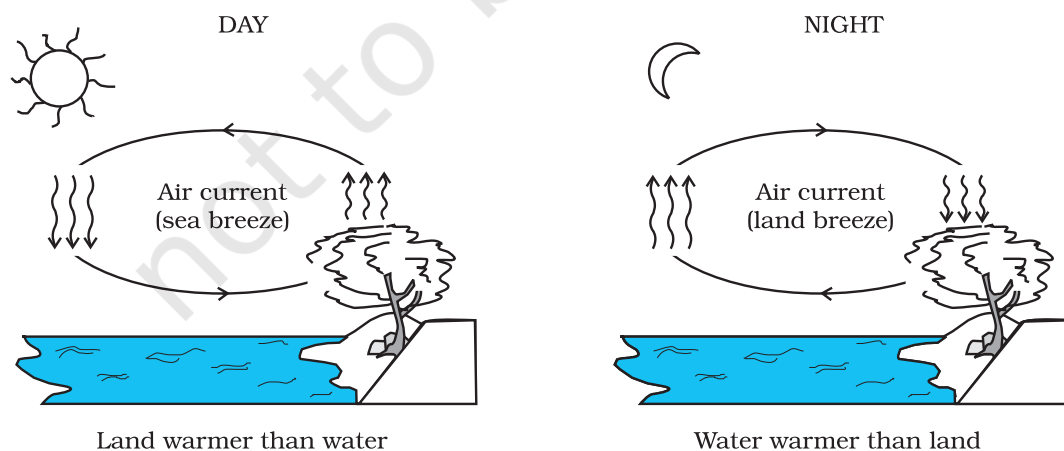

Fig. 10.17 Convection cycles.

### 10.9.3 Radiation

Conduction and convection require some material as a transport medium. These modes of heat transfer cannot operate between bodies separated by a distance in vacuum. But the earth does receive heat from the Sun across a huge distance. Similarly, we quickly feel the warmth of the fire nearby even though air conducts poorly and before convection takes some time to set in. The third mechanism for heat transfer needs no medium; it is called radiation and the energy so transferred by electromagnetic waves is called radiant energy. In an electromagnetic wave, electric and magnetic fields oscillate in space and time. Like any wave, electromagnetic waves can have different wavelengths and can travel in vacuum with the same speed, namely the speed of light i.e.,  $3 \times 10^8 \text{ m s}^{-1}$ . You will learn these matters in more detail later, but you now know why heat transfer by radiation does not need any medium and why it is so fast. This is how heat is transferred to the earth from the Sun through empty space. All bodies emit radiant energy, whether they are solid, liquid or gas. The electromagnetic radiation emitted by a body by virtue of its temperature, like radiation by a red hot iron or light from a filament lamp is called thermal radiation.

When this thermal radiation falls on other bodies, it is partly reflected and partly absorbed. The amount of heat that a body can absorb by radiation depends on the colour of the body.

We find that black bodies absorb and emit radiant energy better than bodies of lighter colours. This fact finds many applications in our daily life. We wear white or light coloured clothes in summer, so that they absorb the least heat from the Sun. However, during winter, we use dark coloured clothes, which absorb heat from the sun and keep our body warm. The bottoms of utensils for cooking food are blackened so that they absorb maximum heat from fire and transfer it to the vegetables to be cooked.

Similarly, a Dewar flask or thermos bottle is a device to minimise heat transfer between the contents of the bottle and outside. It consists of a double-walled glass vessel with the inner and outer walls coated with silver. Radiation from the inner wall is reflected back to the

contents of the bottle. The outer wall similarly reflects back any incoming radiation. The space between the walls is evacuated to reduce conduction and convection losses and the flask is supported on an insulator, like cork. The device is, therefore, useful for preventing hot contents (like, milk) from getting cold, or alternatively, to store cold contents (like, ice).

### 10.9.4 Blackbody Radiation

We have so far not mentioned the wavelength content of thermal radiation. The important thing about thermal radiation at any temperature is that it is not of one (or a few) wavelength(s) but has a continuous spectrum from the small to the long wavelengths. The energy content of radiation, however, varies for different wavelengths. Figure 10.18 gives the experimental curves for radiation energy per unit area per unit wavelength emitted by a blackbody versus wavelength for different temperatures.

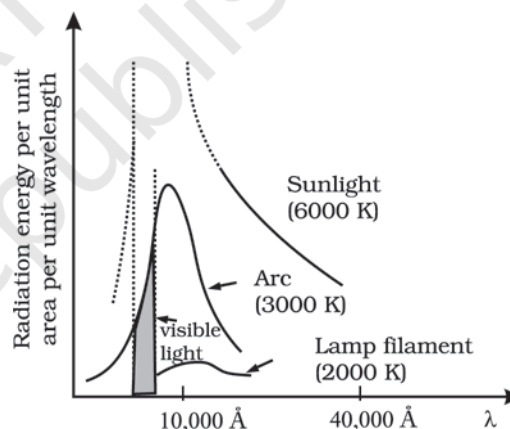

**Fig. 10.18:** Energy emitted versus wavelength for a blackbody at different temperatures

Notice that the wavelength  $\lambda_m$  for which energy is the maximum decreases with increasing temperature. The relation between  $\lambda_m$  and  $T$  is given by what is known as **Wien's Displacement Law**:

$$\lambda_m T = \text{constant} \quad (10.15)$$

The value of the constant (Wien's constant) is  $2.9 \times 10^{-3} \text{ m K}$ . This law explains why the colour of a piece of iron heated in a hot flame first becomes dull red, then reddish yellow, and finally white hot. Wien's law is useful for estimating the surface temperatures of celestial

bodies like, the moon, Sun and other stars. Light from the moon is found to have a maximum intensity near the wavelength  $14 \mu\text{m}$ . By Wien's law, the surface of the moon is estimated to have a temperature of 200 K. Solar radiation has a maximum at  $\lambda_m = 4753 \text{ \AA}$ . This corresponds to  $T = 6060 \text{ K}$ . Remember, this is the temperature of the surface of the sun, not its interior.

The most significant feature of the blackbody radiation curves in Fig. 10.18 is that they are *universal*. They depend only on the temperature and not on the size, shape or material of the blackbody. Attempts to explain blackbody radiation theoretically, at the beginning of the twentieth century, spurred the quantum revolution in physics, as you will learn in later courses.

Energy can be transferred by radiation over large distances, without a medium (i.e., in vacuum). The total electromagnetic energy radiated by a body at absolute temperature  $T$  is proportional to its size, its ability to radiate (called emissivity) and most importantly to its temperature. For a body, which is a perfect radiator, the energy emitted per unit time ( $H$ ) is given by

$$H = A\sigma T^4 \quad (10.16)$$

where  $A$  is the area and  $T$  is the absolute temperature of the body. This relation obtained experimentally by Stefan and later proved theoretically by Boltzmann is known as **Stefan-Boltzmann law** and the constant  $\sigma$  is called Stefan-Boltzmann constant. Its value in SI units is  $5.67 \times 10^{-8} \text{ W m}^{-2} \text{ K}^{-4}$ . Most bodies emit only a fraction of the rate given by Eq. 10.16. A substance like lamp black comes close to the limit. One, therefore, defines a dimensionless fraction  $e$  called *emissivity* and writes,

$$H = Ae\sigma T^4 \quad (10.17)$$

Here,  $e = 1$  for a perfect radiator. For a tungsten lamp, for example,  $e$  is about 0.4. Thus, a tungsten lamp at a temperature of 3000 K and a surface area of  $0.3 \text{ cm}^2$  radiates at the rate  $H = 0.3 \times 10^{-4} \times 0.4 \times 5.67 \times 10^{-8} \times (3000)^4 = 60 \text{ W}$ .

A body at temperature  $T$ , with surroundings at temperatures  $T_s$ , emits, as well as, receives energy. For a perfect radiator, the net rate of loss of radiant energy is

$$H = \sigma A (T^4 - T_s^4)$$

For a body with emissivity  $e$ , the relation modifies to

$$H = e\sigma A (T^4 - T_s^4) \quad (10.18)$$

As an example, let us estimate the heat radiated by our bodies. Suppose the surface area of a person's body is about  $1.9 \text{ m}^2$  and the room temperature is  $22 \text{ }^\circ\text{C}$ . The internal body temperature, as we know, is about  $37 \text{ }^\circ\text{C}$ . The skin temperature may be  $28 \text{ }^\circ\text{C}$  (say). The emissivity of the skin is about 0.97 for the relevant region of electromagnetic radiation. The rate of heat loss is:

$$\begin{aligned} H &= 5.67 \times 10^{-8} \times 1.9 \times 0.97 \times \{(301)^4 - (295)^4\} \\ &= 66.4 \text{ W} \end{aligned}$$

which is more than half the rate of energy production by the body at rest (120 W). To prevent this heat loss effectively (better than ordinary clothing), modern arctic clothing has an additional thin shiny metallic layer next to the skin, which reflects the body's radiation.

### 10.10 NEWTON'S LAW OF COOLING

We all know that hot water or milk when left on a table begins to cool, gradually. Ultimately it attains the temperature of the surroundings. To study how slow or fast a given body can cool on exchanging heat with its surroundings, let us perform the following activity.

Take some water, say 300 mL, in a calorimeter with a stirrer and cover it with a two-holed lid. Fix the stirrer through one hole and fix a thermometer through another hole in the lid and make sure that the bulb of thermometer is immersed in the water. Note the reading of the thermometer. This reading  $T_1$  is the temperature of the surroundings. Heat the water kept in the calorimeter till it attains a temperature, say  $40 \text{ }^\circ\text{C}$  above room temperature (i.e., temperature of the surroundings). Then, stop heating the water by removing the heat source. Start the stop-watch and note the reading of the thermometer after a fixed interval of time, say after every one minute of stirring gently with the stirrer. Continue to note the temperature ( $T_2$ ) of water till it attains a temperature about  $5 \text{ }^\circ\text{C}$  above that of the surroundings. Then, plot

a graph by taking each value of temperature  $\Delta T = T_2 - T_1$  along y-axis and the corresponding value of  $t$  along x-axis (Fig. 10.19).

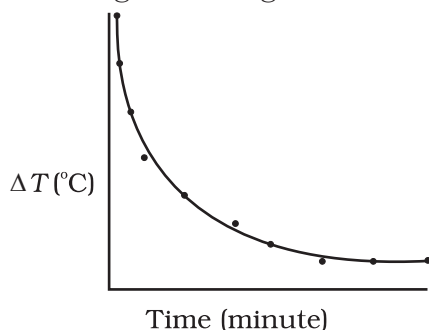

**Fig. 10.19** Curve showing cooling of hot water with time.

From the graph you can infer how the cooling of hot water depends on the difference of its temperature from that of the surroundings. You will also notice that initially the rate of cooling is higher and decreases as the temperature of the body falls.

The above activity shows that a hot body loses heat to its surroundings in the form of heat radiation. The rate of loss of heat depends on the difference in temperature between the body and its surroundings. Newton was the first to study, in a systematic manner, the relation between the heat lost by a body in a given enclosure and its temperature.

According to Newton's law of cooling, the rate of loss of heat,  $-dQ/dt$  of the body is directly proportional to the difference of temperature  $\Delta T = (T_2 - T_1)$  of the body and the surroundings. The law holds good only for small difference of temperature. Also, the loss of heat by radiation depends upon the nature of the surface of the body and the area of the exposed surface. We can write

$$-\frac{dQ}{dt} = k(T_2 - T_1) \quad (10.19)$$

where  $k$  is a positive constant depending upon the area and nature of the surface of the body. Suppose a body of mass  $m$  and specific heat capacity  $s$  is at temperature  $T_2$ . Let  $T_1$  be the temperature of the surroundings. If the temperature falls by a small amount  $dT_2$  in time  $dt$ , then the amount of heat lost is

$$dQ = ms dT_2$$

$\therefore$  Rate of loss of heat is given by

$$\frac{dQ}{dt} = ms \frac{dT_2}{dt} \quad (10.20)$$

From Eqs. (10.15) and (10.16) we have

$$-ms \frac{dT_2}{dt} = k(T_2 - T_1)$$

$$\frac{dT_2}{T_2 - T_1} = -\frac{k}{ms} dt = -K dt \quad (10.21)$$

where  $K = k/ms$

On integrating,

$$\log_e (T_2 - T_1) = -Kt + c \quad (10.22)$$

$$\text{or } T_2 = T_1 + C' e^{-Kt}, \text{ where } C' = e^c \quad (10.23)$$

Equation (10.23) enables you to calculate the time of cooling of a body through a particular range of temperature.

For small temperature differences, the rate of cooling, due to conduction, convection, and radiation combined, is proportional to the difference in temperature. It is a valid approximation in the transfer of heat from a radiator to a room, the loss of heat through the wall of a room, or the cooling of a cup of tea on the table.

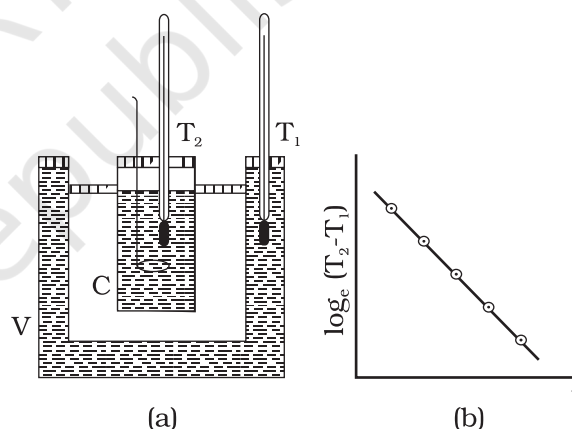

**Fig. 10.20** Verification of Newton's Law of cooling.

Newton's law of cooling can be verified with the help of the experimental set-up shown in Fig. 10.20(a). The set-up consists of a double-walled vessel (V) containing water between the two walls. A copper calorimeter (C) containing hot water is placed inside the double-walled vessel. Two thermometers through the corks are used to note the temperatures  $T_2$  of water in calorimeter and  $T_1$  of hot water in between the double walls, respectively. Temperature of hot water in the calorimeter is noted after equal intervals of time. A graph is plotted between  $\log_e (T_2 - T_1)$  [or  $\ln(T_2 - T_1)$ ] and time ( $t$ ). The nature of the

graph is observed to be a straight line having a negative slope as shown in Fig. 10.20(b). This is in support of Eq. 10.22.

► **Example 10.8** A pan filled with hot food cools from 94 °C to 86 °C in 2 minutes when the room temperature is at 20 °C. How long will it take to cool from 71 °C to 69 °C?

**Answer** The average temperature of 94 °C and 86 °C is 90 °C, which is 70 °C above the room temperature. Under these conditions the pan cools 8 °C in 2 minutes.

Using Eq. (10.21), we have

$$\frac{\text{Change in temperature}}{\text{Time}} = K\Delta T$$

$$\frac{8^\circ\text{C}}{2 \text{ min}} = K(70^\circ\text{C})$$

The average of 69 °C and 71 °C is 70 °C, which is 50 °C above room temperature.  $K$  is the same for this situation as for the original.

$$\frac{2^\circ\text{C}}{\text{Time}} = K(50^\circ\text{C})$$

When we divide above two equations, we have

$$\frac{8^\circ\text{C}/2 \text{ min}}{2^\circ\text{C}/\text{time}} = \frac{K(70^\circ\text{C})}{K(50^\circ\text{C})}$$

$$\begin{aligned} \text{Time} &= 0.7 \text{ min} \\ &= 42 \text{ s} \end{aligned}$$

### SUMMARY

- Heat is a form of energy that flows between a body and its surrounding medium by virtue of temperature difference between them. The degree of hotness of the body is quantitatively represented by temperature.
- A temperature-measuring device (thermometer) makes use of some measurable property (called thermometric property) that changes with temperature. Different thermometers lead to different temperature scales. To construct a temperature scale, two fixed points are chosen and assigned some arbitrary values of temperature. The two numbers fix the origin of the scale and the size of its unit.
- The Celsius temperature ( $t_c$ ) and the Fahrenheit temperature ( $t_f$ ) are related by

$$t_f = (9/5) t_c + 32$$

- The ideal gas equation connecting pressure ( $P$ ), volume ( $V$ ) and absolute temperature ( $T$ ) is :

$$PV = \mu RT$$

where  $\mu$  is the number of moles and  $R$  is the universal gas constant.

- In the absolute temperature scale, the zero of the scale corresponds to the temperature where every substance in nature has the least possible molecular activity. The Kelvin absolute temperature scale ( $T$ ) has the same unit size as the Celsius scale ( $T_c$ ), but differs in the origin :

$$T_c = T - 273.15$$

- The coefficient of linear expansion ( $\alpha_l$ ) and volume expansion ( $\alpha_v$ ) are defined by the relations :

$$\frac{\Delta l}{l} = \alpha_l \Delta T$$

$$\frac{\Delta V}{V} = \alpha_v \Delta T$$

where  $\Delta l$  and  $\Delta V$  denote the change in length  $l$  and volume  $V$  for a change of temperature  $\Delta T$ . The relation between them is :

$$\alpha_v = 3 \alpha_l$$

7. The specific heat capacity of a substance is defined by

$$s = \frac{1}{m} \frac{\Delta Q}{\Delta T}$$

where  $m$  is the mass of the substance and  $\Delta Q$  is the heat required to change its temperature by  $\Delta T$ . The molar specific heat capacity of a substance is defined by

$$C = \frac{1}{\mu} \frac{\Delta Q}{\Delta T}$$

where  $\mu$  is the number of moles of the substance.

8. The latent heat of fusion ( $L_f$ ) is the heat per unit mass required to change a substance from solid into liquid at the same temperature and pressure. The latent heat of vapourisation ( $L_v$ ) is the heat per unit mass required to change a substance from liquid to the vapour state without change in the temperature and pressure.
9. The three modes of heat transfer are conduction, convection and radiation.
10. In conduction, heat is transferred between neighbouring parts of a body through molecular collisions, without any flow of matter. For a bar of length  $L$  and uniform cross section  $A$  with its ends maintained at temperatures  $T_c$  and  $T_d$ , the rate of flow of heat  $H$  is :

$$H = K A \frac{T_c - T_d}{L}$$

where  $K$  is the thermal conductivity of the material of the bar.

11. Newton's Law of Cooling says that the rate of cooling of a body is proportional to the excess temperature of the body over the surroundings :

$$\frac{dQ}{dt} = -k(T_2 - T_1)$$

Where  $T_1$  is the temperature of the surrounding medium and  $T_2$  is the temperature of the body.

Quantity	Symbol	Dimensions	Unit	Remark
Amount of substance	$\mu$	[mol]	mol	
Celsius temperature	$t_c$	[K]	°C	
Kelvin absolute temperature	$T$	[K]	K	$t_c = T - 273.15$
Co-efficient of linear expansion	$\alpha_l$	[K <sup>-1</sup> ]	K <sup>-1</sup>	
Co-efficient of volume expansion	$\alpha_v$	[K <sup>-1</sup> ]	K <sup>-1</sup>	$\alpha_v = 3 \alpha_l$
Heat supplied to a system	$\Delta Q$	[ML <sup>2</sup> T <sup>-2</sup> ]	J	$Q$ is not a state variable
Specific heat capacity	$s$	[L <sup>2</sup> T <sup>-2</sup> K <sup>-1</sup> ]	J kg <sup>-1</sup> K <sup>-1</sup>	
Thermal Conductivity	$K$	[M LT <sup>-3</sup> K <sup>-1</sup> ]	J s <sup>-1</sup> K <sup>-1</sup>	$H = -KA \frac{dT}{dx}$

**POINTS TO PONDER**

1. The relation connecting Kelvin temperature ( $T$ ) and the Celsius temperature  $t_c$

$$T = t_c + 273.15$$

and the assignment  $T = 273.16$  K for the triple point of water are exact relations (by choice). With this choice, the Celsius temperature of the melting point of water and boiling point of water (both at 1 atm pressure) are very close to, but not exactly equal to  $0^\circ\text{C}$  and  $100^\circ\text{C}$  respectively. In the original Celsius scale, these latter fixed points were exactly at  $0^\circ\text{C}$  and  $100^\circ\text{C}$  (by choice), but now the triple point of water is the preferred choice for the fixed point, because it has a unique temperature.

2. A liquid in equilibrium with vapour has the same pressure and temperature throughout the system; the two phases in equilibrium differ in their molar volume (i.e. density). This is true for a system with any number of phases in equilibrium.
3. Heat transfer always involves temperature difference between two systems or two parts of the same system. Any energy transfer that does not involve temperature difference in some way is not heat.
4. Convection involves flow of matter *within a fluid* due to unequal temperatures of its parts. A hot bar placed under a running tap loses heat by conduction between the surface of the bar and water and not by convection within water.

**EXERCISES**

- 10.1** The triple points of neon and carbon dioxide are 24.57 K and 216.55 K respectively. Express these temperatures on the Celsius and Fahrenheit scales.

- 10.2** Two absolute scales  $A$  and  $B$  have triple points of water defined to be 200 A and 350 B. What is the relation between  $T_A$  and  $T_B$ ?

- 10.3** The electrical resistance in ohms of a certain thermometer varies with temperature according to the approximate law :

$$R = R_0 [1 + \alpha (T - T_0)]$$

The resistance is  $101.6 \Omega$  at the triple-point of water  $273.16$  K, and  $165.5 \Omega$  at the normal melting point of lead ( $600.5$  K). What is the temperature when the resistance is  $123.4 \Omega$ ?

- 10.4** Answer the following :

- (a) The triple-point of water is a standard fixed point in modern thermometry. Why? What is wrong in taking the melting point of ice and the boiling point of water as standard fixed points (as was originally done in the Celsius scale)?
- (b) There were two fixed points in the original Celsius scale as mentioned above which were assigned the number  $0^\circ\text{C}$  and  $100^\circ\text{C}$  respectively. On the absolute scale, one of the fixed points is the triple-point of water, which on the Kelvin absolute scale is assigned the number  $273.16$  K. What is the other fixed point on this (Kelvin) scale?
- (c) The absolute temperature (Kelvin scale)  $T$  is related to the temperature  $t_c$  on the Celsius scale by

$$t_c = T - 273.15$$

Why do we have 273.15 in this relation, and not 273.16?

- (d) What is the temperature of the triple-point of water on an absolute scale whose unit interval size is equal to that of the Fahrenheit scale?

- 10.5** Two ideal gas thermometers  $A$  and  $B$  use oxygen and hydrogen respectively. The following observations are made :



Temperature	Pressure thermometer A	Pressure thermometer B
Triple-point of water	$1.250 \times 10^5$ Pa	$0.200 \times 10^5$ Pa
Normal melting point of sulphur	$1.797 \times 10^5$ Pa	$0.287 \times 10^5$ Pa

- (a) What is the absolute temperature of normal melting point of sulphur as read by thermometers *A* and *B* ?
- (b) What do you think is the reason behind the slight difference in answers of thermometers *A* and *B* ? (The thermometers are not faulty). What further procedure is needed in the experiment to reduce the discrepancy between the two readings ?

- 10.6** A steel tape 1m long is correctly calibrated for a temperature of  $27.0^\circ\text{C}$ . The length of a steel rod measured by this tape is found to be 63.0 cm on a hot day when the temperature is  $45.0^\circ\text{C}$ . What is the actual length of the steel rod on that day ? What is the length of the same steel rod on a day when the temperature is  $27.0^\circ\text{C}$  ? Coefficient of linear expansion of steel =  $1.20 \times 10^{-5} \text{K}^{-1}$ .
- 10.7** A large steel wheel is to be fitted on to a shaft of the same material. At  $27^\circ\text{C}$ , the outer diameter of the shaft is 8.70 cm and the diameter of the central hole in the wheel is 8.69 cm. The shaft is cooled using 'dry ice'. At what temperature of the shaft does the wheel slip on the shaft? Assume coefficient of linear expansion of the steel to be constant over the required temperature range :  $\alpha_{\text{steel}} = 1.20 \times 10^{-5} \text{K}^{-1}$ .
- 10.8** A hole is drilled in a copper sheet. The diameter of the hole is 4.24 cm at  $27.0^\circ\text{C}$ . What is the change in the diameter of the hole when the sheet is heated to  $227^\circ\text{C}$ ? Coefficient of linear expansion of copper =  $1.70 \times 10^{-5} \text{K}^{-1}$ .
- 10.9** A brass wire 1.8 m long at  $27^\circ\text{C}$  is held taut with little tension between two rigid supports. If the wire is cooled to a temperature of  $-39^\circ\text{C}$ , what is the tension developed in the wire, if its diameter is 2.0 mm ? Co-efficient of linear expansion of brass =  $2.0 \times 10^{-5} \text{K}^{-1}$ ; Young's modulus of brass =  $0.91 \times 10^{11} \text{Pa}$ .
- 10.10** A brass rod of length 50 cm and diameter 3.0 mm is joined to a steel rod of the same length and diameter. What is the change in length of the combined rod at  $250^\circ\text{C}$ , if the original lengths are at  $40.0^\circ\text{C}$ ? Is there a 'thermal stress' developed at the junction ? The ends of the rod are free to expand (Co-efficient of linear expansion of brass =  $2.0 \times 10^{-5} \text{K}^{-1}$ , steel =  $1.2 \times 10^{-5} \text{K}^{-1}$ ).
- 10.11** The coefficient of volume expansion of glycerine is  $49 \times 10^{-5} \text{K}^{-1}$ . What is the fractional change in its density for a  $30^\circ\text{C}$  rise in temperature ?
- 10.12** A 10 kW drilling machine is used to drill a bore in a small aluminium block of mass 8.0 kg. How much is the rise in temperature of the block in 2.5 minutes, assuming 50% of power is used up in heating the machine itself or lost to the surroundings. Specific heat of aluminium =  $0.91 \text{J g}^{-1} \text{K}^{-1}$ .
- 10.13** A copper block of mass 2.5 kg is heated in a furnace to a temperature of  $500^\circ\text{C}$  and then placed on a large ice block. What is the maximum amount of ice that can melt? (Specific heat of copper =  $0.39 \text{J g}^{-1} \text{K}^{-1}$ ; heat of fusion of water =  $335 \text{J g}^{-1}$ ).
- 10.14** In an experiment on the specific heat of a metal, a 0.20 kg block of the metal at  $150^\circ\text{C}$  is dropped in a copper calorimeter (of water equivalent 0.025 kg) containing  $150 \text{cm}^3$  of water at  $27^\circ\text{C}$ . The final temperature is  $40^\circ\text{C}$ . Compute the specific heat of the metal. If heat losses to the surroundings are not negligible, is your answer greater or smaller than the actual value for specific heat of the metal ?
- 10.15** Given below are observations on molar specific heats at room temperature of some common gases.

Gas	Molar specific heat ( $C_v$ ) ( $\text{cal mol}^{-1} \text{K}^{-1}$ )
Hydrogen	4.87
Nitrogen	4.97
Oxygen	5.02
Nitric oxide	4.99
Carbon monoxide	5.01
Chlorine	6.17

The measured molar specific heats of these gases are markedly different from those for monatomic gases. Typically, molar specific heat of a monatomic gas is  $2.92 \text{ cal/mol K}$ . Explain this difference. What can you infer from the somewhat larger (than the rest) value for chlorine?

- 10.16** A child running a temperature of  $101^\circ\text{F}$  is given an antipyrin (i.e. a medicine that lowers fever) which causes an increase in the rate of evaporation of sweat from his body. If the fever is brought down to  $98^\circ\text{F}$  in 20 minutes, what is the average rate of extra evaporation caused, by the drug. Assume the evaporation mechanism to be the only way by which heat is lost. The mass of the child is 30 kg. The specific heat of human body is approximately the same as that of water, and latent heat of evaporation of water at that temperature is about  $580 \text{ cal g}^{-1}$ .
- 10.17** A 'thermacole' icebox is a cheap and an efficient method for storing small quantities of cooked food in summer in particular. A cubical icebox of side 30 cm has a thickness of 5.0 cm. If 4.0 kg of ice is put in the box, estimate the amount of ice remaining after 6 h. The outside temperature is  $45^\circ\text{C}$ , and co-efficient of thermal conductivity of thermacole is  $0.01 \text{ J s}^{-1} \text{ m}^{-1} \text{ K}^{-1}$ . [Heat of fusion of water =  $335 \times 10^3 \text{ J kg}^{-1}$ ]
- 10.18** A brass boiler has a base area of  $0.15 \text{ m}^2$  and thickness 1.0 cm. It boils water at the rate of 6.0 kg/min when placed on a gas stove. Estimate the temperature of the part of the flame in contact with the boiler. Thermal conductivity of brass =  $109 \text{ J s}^{-1} \text{ m}^{-1} \text{ K}^{-1}$ ; Heat of vaporisation of water =  $2256 \times 10^3 \text{ J kg}^{-1}$ .
- 10.19** Explain why :
- a body with large reflectivity is a poor emitter
  - a brass tumbler feels much colder than a wooden tray on a chilly day
  - an optical pyrometer (for measuring high temperatures) calibrated for an ideal black body radiation gives too low a value for the temperature of a red hot iron piece in the open, but gives a correct value for the temperature when the same piece is in the furnace
  - the earth without its atmosphere would be inhospitably cold
  - heating systems based on circulation of steam are more efficient in warming a building than those based on circulation of hot water
- 10.20** A body cools from  $80^\circ\text{C}$  to  $50^\circ\text{C}$  in 5 minutes. Calculate the time it takes to cool from  $60^\circ\text{C}$  to  $30^\circ\text{C}$ . The temperature of the surroundings is  $20^\circ\text{C}$ .



# THERMODYNAMICS

- 11.1 Introduction
  - 11.2 Thermal equilibrium
  - 11.3 Zeroth law of Thermodynamics
  - 11.4 Heat, internal energy and work
  - 11.5 First law of thermodynamics
  - 11.6 Specific heat capacity
  - 11.7 Thermodynamic state variables and equation of state
  - 11.8 Thermodynamic processes
  - 11.9 Second law of thermodynamics
  - 11.10 Reversible and irreversible processes
  - 11.11 Carnot engine
- Summary  
Points to ponder  
Exercises

## 11.1 INTRODUCTION

In previous chapter we have studied thermal properties of matter. In this chapter we shall study laws that govern thermal energy. We shall study the processes where work is converted into heat and vice versa. In winter, when we rub our palms together, we feel warmer; here work done in rubbing produces the 'heat'. Conversely, in a steam engine, the 'heat' of the steam is used to do useful work in moving the pistons, which in turn rotate the wheels of the train.

In physics, we need to define the notions of heat, temperature, work, etc. more carefully. Historically, it took a long time to arrive at the proper concept of 'heat'. Before the modern picture, heat was regarded as a fine invisible fluid filling in the pores of a substance. On contact between a hot body and a cold body, the fluid (called caloric) flowed from the colder to the hotter body ! This is similar to what happens when a horizontal pipe connects two tanks containing water up to different heights. The flow continues until the levels of water in the two tanks are the same. Likewise, in the 'caloric' picture of heat, heat flows until the 'caloric levels' (i.e., the temperatures) equalise.

In time, the picture of heat as a fluid was discarded in favour of the modern concept of heat as a form of energy. An important experiment in this connection was due to Benjamin Thomson (also known as Count Rumford) in 1798. He observed that boring of a brass cannon generated a lot of heat, indeed enough to boil water. More significantly, the amount of heat produced depended on the work done (by the horses employed for turning the drill) but not on the sharpness of the drill. In the caloric picture, a sharper drill would scoop out more heat fluid from the pores; but this was not observed. A most natural explanation of the observations was that heat was a form of energy and the experiment demonstrated conversion of energy from one form to another—from work to heat.

Thermodynamics is the branch of physics that deals with the concepts of heat and temperature and the inter-conversion of heat and other forms of energy. Thermodynamics is a macroscopic science. It deals with bulk systems and does not go into the molecular constitution of matter. In fact, its concepts and laws were formulated in the nineteenth century before the molecular picture of matter was firmly established. Thermodynamic description involves relatively few macroscopic variables of the system, which are suggested by common sense and can be usually measured directly. A microscopic description of a gas, for example, would involve specifying the co-ordinates and velocities of the huge number of molecules constituting the gas. The description in kinetic theory of gases is not so detailed but it does involve molecular distribution of velocities. Thermodynamic description of a gas, on the other hand, avoids the molecular description altogether. Instead, the state of a gas in thermodynamics is specified by macroscopic variables such as pressure, volume, temperature, mass and composition that are felt by our sense perceptions and are measurable\*.

The distinction between mechanics and thermodynamics is worth bearing in mind. In mechanics, our interest is in the motion of particles or bodies under the action of forces and torques. Thermodynamics is not concerned with the motion of the system as a whole. It is concerned with the internal macroscopic state of the body. When a bullet is fired from a gun, what changes is the mechanical state of the bullet (its kinetic energy, in particular), not its temperature. When the bullet pierces a wood and stops, the kinetic energy of the bullet gets converted into heat, changing the temperature of the bullet and the surrounding layers of wood. Temperature is related to the energy of the internal (disordered) motion of the bullet, not to the motion of the bullet as a whole.

## 11.2 THERMAL EQUILIBRIUM

Equilibrium in mechanics means that the net external force and torque on a system are zero. The term 'equilibrium' in thermodynamics appears

in a different context : we say the state of a system is an equilibrium state if the macroscopic variables that characterise the system do not change in time. For example, a gas inside a closed rigid container, completely insulated from its surroundings, with fixed values of pressure, volume, temperature, mass and composition that do not change with time, is in a state of thermodynamic equilibrium.

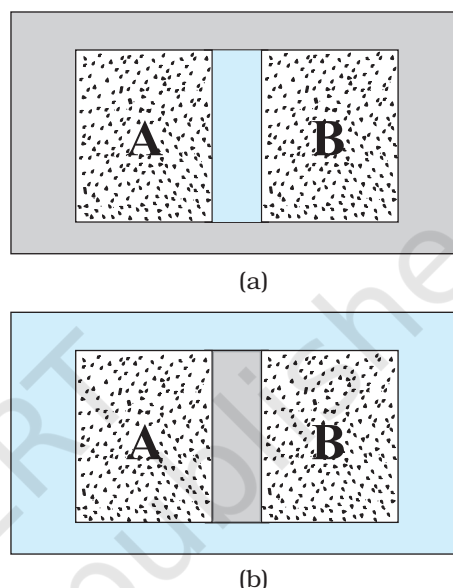

**Fig. 11.1** (a) Systems A and B (two gases) separated by an adiabatic wall – an insulating wall that does not allow flow of heat. (b) The same systems A and B separated by a diathermic wall – a conducting wall that allows heat to flow from one to another. In this case, thermal equilibrium is attained in due course.

In general, whether or not a system is in a state of equilibrium depends on the surroundings and the nature of the wall that separates the system from the surroundings. Consider two gases A and B occupying two different containers. We know experimentally that pressure and volume of a given mass of gas can be chosen to be its two independent variables. Let the pressure and volume of the gases be  $(P_A, V_A)$  and  $(P_B, V_B)$  respectively. Suppose first that the two systems are put in proximity but are separated by an

\* Thermodynamics may also involve other variables that are not so obvious to our senses e.g. entropy, enthalpy, etc., and they are all macroscopic variables. However, a thermodynamic state is specified by five state variables viz., pressure, volume, temperature, internal energy and entropy. Entropy is a measure of disorderliness in the system. Enthalpy is a measure of total heat content of the system.

**adiabatic wall** – an insulating wall (can be movable) that does not allow flow of energy (heat) from one to another. The systems are insulated from the rest of the surroundings also by similar adiabatic walls. The situation is shown schematically in Fig. 11.1 (a). In this case, it is found that any possible pair of values  $(P_A, V_A)$  will be in equilibrium with any possible pair of values  $(P_B, V_B)$ . Next, suppose that the adiabatic wall is replaced by a **diathermic wall** – a conducting wall that allows energy flow (heat) from one to another. It is then found that the macroscopic variables of the systems  $A$  and  $B$  change spontaneously until both the systems attain equilibrium states. After that there is no change in their states. The situation is shown in Fig. 11.1(b). The pressure and volume variables of the two gases change to  $(P_B', V_B')$  and  $(P_A', V_A')$  such that the new states of  $A$  and  $B$  are in equilibrium with each other\*. There is no more energy flow from one to another. We then say that the system  $A$  is in thermal equilibrium with the system  $B$ .

What characterises the situation of thermal equilibrium between two systems? You can guess the answer from your experience. In thermal equilibrium, the temperatures of the two systems are equal. We shall see how does one arrive at the concept of temperature in thermodynamics? The Zeroth law of thermodynamics provides the clue.

### 11.3 ZEROTH LAW OF THERMODYNAMICS

Imagine two systems  $A$  and  $B$ , separated by an adiabatic wall, while each is in contact with a third system  $C$ , via a conducting wall [Fig. 11.2(a)]. The states of the systems (i.e., their macroscopic variables) will change until both  $A$  and  $B$  come to thermal equilibrium with  $C$ . After this is achieved, suppose that the adiabatic wall between  $A$  and  $B$  is replaced by a conducting wall and  $C$  is insulated from  $A$  and  $B$  by an adiabatic wall [Fig. 11.2(b)]. It is found that the states of  $A$  and  $B$  change no further i.e. they are found **to be in thermal equilibrium with each other**. This observation forms the basis of the **Zeroth Law of Thermodynamics**, which states that **‘two systems in thermal equilibrium with a third system separately are in thermal equilibrium with each other’**. R.H. Fowler formulated this

law in 1931 long after the first and second Laws of thermodynamics were stated and so numbered.

The Zeroth Law clearly suggests that when two systems  $A$  and  $B$ , are in thermal equilibrium, there must be a physical quantity that has the same value for both. This thermodynamic variable whose value is equal for two systems in thermal equilibrium is called temperature ( $T$ ). Thus, if  $A$  and  $B$  are separately in equilibrium with  $C$ ,  $T_A = T_C$  and  $T_B = T_C$ . This implies that  $T_A = T_B$  i.e. the systems  $A$  and  $B$  are also in thermal equilibrium.

We have arrived at the concept of temperature formally via the Zeroth Law. The next question is : how to assign numerical values to temperatures of different bodies? In other words, how do we construct a scale of temperature? Thermometry deals with this basic question to which we turn in the next section.

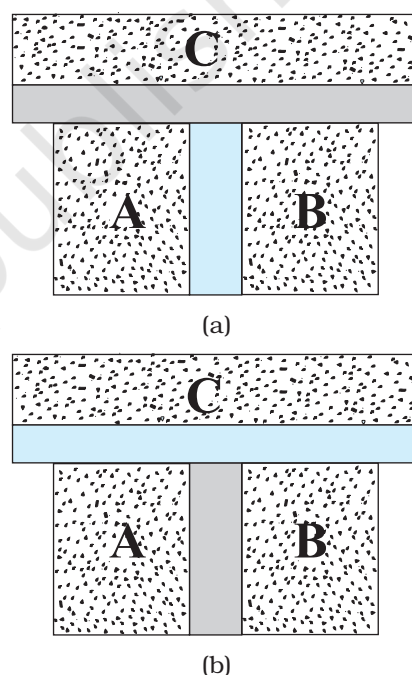

**Fig. 11.2** (a) Systems  $A$  and  $B$  are separated by an adiabatic wall, while each is in contact with a third system  $C$  via a conducting wall. (b) The adiabatic wall between  $A$  and  $B$  is replaced by a conducting wall, while  $C$  is insulated from  $A$  and  $B$  by an adiabatic wall.

\* Both the variables need not change. It depends on the constraints. For instance, if the gases are in containers of fixed volume, only the pressures of the gases would change to achieve thermal equilibrium.

### 11.4 HEAT, INTERNAL ENERGY AND WORK

The Zeroth Law of Thermodynamics led us to the concept of temperature that agrees with our commonsense notion. Temperature is a marker of the 'hotness' of a body. It determines the direction of flow of heat when two bodies are placed in thermal contact. Heat flows from the body at a higher temperature to the one at lower temperature. The flow stops when the temperatures equalise; the two bodies are then in thermal equilibrium. We saw in some detail how to construct temperature scales to assign temperatures to different bodies. We now describe the concepts of heat and other relevant quantities like internal energy and work.

The concept of internal energy of a system is not difficult to understand. We know that every bulk system consists of a large number of molecules. Internal energy is simply the sum of the kinetic energies and potential energies of these molecules. We remarked earlier that in thermodynamics, the kinetic energy of the system, as a whole, is not relevant. Internal energy is thus, the sum of molecular kinetic and potential energies in the frame of reference relative to which the centre of mass of the system is at rest. Thus, it includes only the (disordered) energy associated with the random motion of molecules of the system. We denote the internal energy of a system by  $U$ .

Though we have invoked the molecular picture to understand the meaning of internal energy, as far as thermodynamics is concerned,  $U$  is simply a macroscopic variable of the system. The important thing about internal energy is that it depends only on the state of the system, not on how that state was achieved. Internal energy  $U$  of a system is an example of a thermodynamic 'state variable' – its value depends only on the given state of the system, not on history i.e. not on the 'path' taken to arrive at that state. Thus, the internal energy of a given mass of gas depends on its state described by specific values of pressure, volume and temperature. It does not depend on how this state of the gas came about. Pressure, volume, temperature, and internal energy are thermodynamic state variables of the system (gas) (see section 11.7). If we neglect the small intermolecular forces in a gas, the internal energy of a gas is just the sum of kinetic energies

associated with various random motions of its molecules. We will see in the next chapter that in a gas this motion is not only translational (i.e. motion from one point to another in the volume of the container); it also includes rotational and vibrational motion of the molecules (Fig. 11.3).

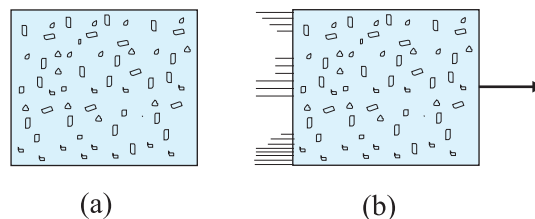

**Fig. 11.3** (a) Internal energy  $U$  of a gas is the sum of the kinetic and potential energies of its molecules when the box is at rest. Kinetic energy due to various types of motion (translational, rotational, vibrational) is to be included in  $U$ . (b) If the same box is moving as a whole with some velocity, the kinetic energy of the box is not to be included in  $U$ .

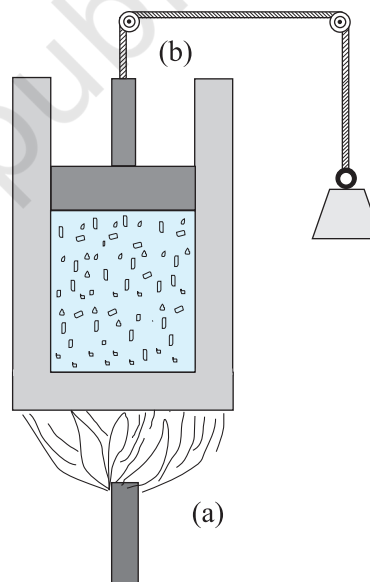

**Fig. 11.4** Heat and work are two distinct modes of energy transfer to a system that results in change in its internal energy. (a) Heat is energy transfer due to temperature difference between the system and the surroundings. (b) Work is energy transfer brought about by means (e.g. moving the piston by raising or lowering some weight connected to it) that do not involve such a temperature difference.

What are the ways of changing internal energy of a system ? Consider again, for simplicity, the system to be a certain mass of gas contained in a cylinder with a movable piston as shown in Fig. 11.4. Experience shows there are two ways of changing the state of the gas (and hence its internal energy). One way is to put the cylinder in contact with a body at a higher temperature than that of the gas. The temperature difference will cause a flow of energy (heat) from the hotter body to the gas, thus increasing the internal energy of the gas. The other way is to push the piston down i.e. to do work on the system, which again results in increasing the internal energy of the gas. Of course, both these things could happen in the reverse direction. With surroundings at a lower temperature, heat would flow from the gas to the surroundings. Likewise, the gas could push the piston up and do work on the surroundings. In short, heat and work are two different modes of altering the state of a thermodynamic system and changing its internal energy.

The notion of heat should be carefully distinguished from the notion of internal energy. Heat is certainly energy, but it is the energy in transit. This is not just a play of words. The distinction is of basic significance. The state of a thermodynamic system is characterised by its internal energy, not heat. A statement like **'a gas in a given state has a certain amount of heat'** is as meaningless as the statement that **'a gas in a given state has a certain amount of work'**. In contrast, **'a gas in a given state has a certain amount of internal energy'** is a perfectly meaningful statement. Similarly, the statements **'a certain amount of heat is supplied to the system'** or **'a certain amount of work was done by the system'** are perfectly meaningful.

To summarise, heat and work in thermodynamics are not state variables. They are modes of energy transfer to a system resulting in change in its internal energy, which, as already mentioned, is a state variable.

In ordinary language, we often confuse heat with internal energy. The distinction between them is sometimes ignored in elementary physics books. For proper understanding of thermodynamics, however, the distinction is crucial.

## 11.5 FIRST LAW OF THERMODYNAMICS

We have seen that the internal energy  $U$  of a system can change through two modes of energy transfer : heat and work. Let

$\Delta Q$  = Heat supplied *to* the system *by* the surroundings

$\Delta W$  = Work done *by* the system *on* the surroundings

$\Delta U$  = Change in internal energy of the system

The general principle of conservation of energy then implies that

$$\Delta Q = \Delta U + \Delta W \quad (11.1)$$

i.e. the energy ( $\Delta Q$ ) supplied to the system goes in partly to increase the internal energy of the system ( $\Delta U$ ) and the rest in work on the environment ( $\Delta W$ ). Equation (11.1) is known as the **First Law of Thermodynamics**. It is simply the general law of conservation of energy applied to any system in which the energy transfer from or to the surroundings is taken into account.

Let us put Eq. (11.1) in the alternative form

$$\Delta Q - \Delta W = \Delta U \quad (11.2)$$

Now, the system may go from an initial state to the final state in a number of ways. For example, to change the state of a gas from  $(P_1, V_1)$  to  $(P_2, V_2)$ , we can first change the volume of the gas from  $V_1$  to  $V_2$ , keeping its pressure constant i.e. we can first go to the state  $(P_1, V_2)$  and then change the pressure of the gas from  $P_1$  to  $P_2$ , keeping volume constant, to take the gas to  $(P_2, V_2)$ . Alternatively, we can first keep the volume constant and then keep the pressure constant. Since  $U$  is a state variable,  $\Delta U$  depends only on the initial and final states and not on the path taken by the gas to go from one to the other. However,  $\Delta Q$  and  $\Delta W$  will, in general, depend on the path taken to go from the initial to final states. From the First Law of Thermodynamics, Eq. (11.2), it is clear that the combination  $\Delta Q - \Delta W$ , is however, path independent. This shows that if a system is taken through a process in which  $\Delta U = 0$  (for example, isothermal expansion of an ideal gas, see section 11.8),

$$\Delta Q = \Delta W$$

i.e., heat supplied to the system is used up entirely by the system in doing work on the environment.

If the system is a gas in a cylinder with a movable piston, the gas in moving the piston does work. Since force is pressure times area, and area times displacement is volume, work done by the system against a constant pressure  $P$  is

$$\Delta W = P \Delta V$$

where  $\Delta V$  is the change in volume of the gas. Thus, for this case, Eq. (11.1) gives

$$\Delta Q = \Delta U + P \Delta V \quad (11.3)$$

As an application of Eq. (11.3), consider the change in internal energy for 1 g of water when we go from its liquid to vapour phase. The measured latent heat of water is 2256 J/g. i.e., for 1 g of water  $\Delta Q = 2256$  J. At atmospheric pressure, 1 g of water has a volume 1 cm<sup>3</sup> in liquid phase and 1671 cm<sup>3</sup> in vapour phase.

Therefore,

$$\Delta W = P(V_g - V_l) = 1.013 \times 10^5 \times (1671 \times 10^{-6}) = 169.2 \text{ J}$$

Equation (11.3) then gives

$$\Delta U = 2256 - 169.2 = 2086.8 \text{ J}$$

We see that most of the heat goes to increase the internal energy of water in transition from the liquid to the vapour phase.

### 11.6 SPECIFIC HEAT CAPACITY

Suppose an amount of heat  $\Delta Q$  supplied to a substance changes its temperature from  $T$  to  $T + \Delta T$ . We define heat capacity of a substance (see Chapter 10) to be

$$S = \frac{\Delta Q}{\Delta T} \quad (11.4)$$

We expect  $\Delta Q$  and, therefore, heat capacity  $S$  to be proportional to the mass of the substance. Further, it could also depend on the temperature, i.e., a different amount of heat may be needed for a unit rise in temperature at different temperatures. To define a constant characteristic of the substance and independent of its amount, we divide  $S$  by the mass of the substance  $m$  in kg:

$$s = \frac{S}{m} = \left( \frac{1}{m} \right) \frac{\Delta Q}{\Delta T} \quad (11.5)$$

$s$  is known as the specific heat capacity of the substance. It depends on the nature of the substance and its temperature. The unit of specific heat capacity is J kg<sup>-1</sup> K<sup>-1</sup>.

If the amount of substance is specified in terms of moles  $\mu$  (instead of mass  $m$  in kg), we can define heat capacity per mole of the substance by

$$C = \frac{S}{\mu} = \frac{1}{\mu} \frac{\Delta Q}{\Delta T} \quad (11.6)$$

$C$  is known as molar specific heat capacity of the substance. Like  $s$ ,  $C$  is independent of the amount of substance.  $C$  depends on the nature of the substance, its temperature and the conditions under which heat is supplied. The unit of  $C$  is J mol<sup>-1</sup> K<sup>-1</sup>. As we shall see later (in connection with specific heat capacity of gases), additional conditions may be needed to define  $C$  or  $s$ . The idea in defining  $C$  is that simple predictions can be made in regard to molar specific heat capacities.

Table 11.1 lists measured specific and molar heat capacities of solids at atmospheric pressure and ordinary room temperature.

We will see in Chapter 12 that predictions of specific heats of gases generally agree with experiment. We can use the same law of equipartition of energy that we use there to predict molar specific heat capacities of solids (See Section 12.5 and 12.6). Consider a solid of  $N$  atoms, each vibrating about its mean position. An oscillator in one dimension has average energy of  $2 \times \frac{1}{2} k_B T = k_B T$ . In three dimensions, the average energy is  $3 k_B T$ . For a mole of a solid, the total energy is

$$U = 3 k_B T \times N_A = 3 RT \quad (\because k_B T \times N_A = R)$$

Now, at constant pressure,  $\Delta Q = \Delta U + P \Delta V \cong \Delta U$ , since for a solid  $\Delta V$  is negligible. Therefore,

$$C = \frac{\Delta Q}{\Delta T} = \frac{\Delta U}{\Delta T} = 3R \quad (11.7)$$

**Table 11.1** Specific and molar heat capacities of some solids at room temperature and atmospheric pressure

Substance	Specific <sup>v</sup> heat (J kg <sup>-1</sup> K <sup>-1</sup> )	Molar specific heat (J mol <sup>-1</sup> K <sup>-1</sup> )
Aluminium	900.0	24.4
Carbon	506.5	6.1
Copper	386.4	24.5
Lead	127.7	26.5
Silver	236.1	25.5
Tungsten	134.4	24.9

As Table 11.1 shows, the experimentally measured values which generally agrees with



predicted value  $3R$  at ordinary temperatures. (Carbon is an exception.) The agreement is known to break down at low temperatures.

### Specific heat capacity of water

The old unit of heat was calorie. One calorie was earlier defined to be the amount of heat required to raise the temperature of 1g of water by 1 °C. With more precise measurements, it was found that the specific heat of water varies slightly with temperature. Figure 11.5 shows this variation in the temperature range 0 to 100 °C.

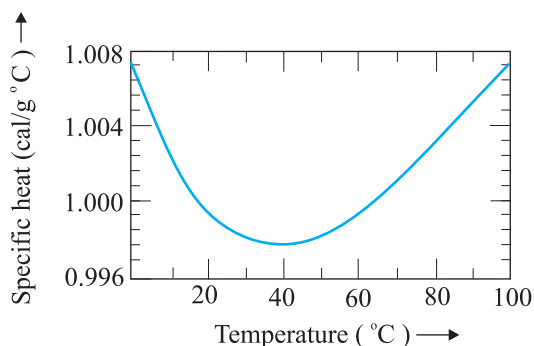

**Fig. 11.5** Variation of specific heat capacity of water with temperature.

For a precise definition of calorie, it was, therefore, necessary to specify the unit temperature interval. One calorie is defined to be the amount of heat required to raise the temperature of 1g of water from 14.5 °C to 15.5 °C. Since heat is just a form of energy, it is preferable to use the unit joule, J. In SI units, the specific heat capacity of water is  $4186 \text{ J kg}^{-1} \text{ K}^{-1}$  i.e.  $4.186 \text{ J g}^{-1} \text{ K}^{-1}$ . The so called mechanical equivalent of heat defined as the amount of work needed to produce 1 cal of heat is in fact just a conversion factor between two different units of energy : calorie to joule. Since in SI units, we use the unit joule for heat, work or any other form of energy, the term mechanical equivalent is now superfluous and need not be used.

As already remarked, the specific heat capacity depends on the process or the conditions under which heat capacity transfer takes place. For gases, for example, we can define two specific heats : **specific heat capacity at constant volume** and **specific heat capacity at constant pressure**. For an

ideal gas, we have a simple relation.

$$C_p - C_v = R \quad (11.8)$$

where  $C_p$  and  $C_v$  are molar specific heat capacities of an ideal gas at constant pressure and volume respectively and  $R$  is the universal gas constant. To prove the relation, we begin with Eq. (11.3) for 1 mole of the gas :

$$\Delta Q = \Delta U + P \Delta V$$

If  $\Delta Q$  is absorbed at constant volume,  $\Delta V = 0$

$$C_v = \left( \frac{\Delta Q}{\Delta T} \right)_v = \left( \frac{\Delta U}{\Delta T} \right)_v = \left( \frac{\Delta U}{\Delta T} \right) \quad (11.9)$$

where the subscript  $v$  is dropped in the last step, since  $U$  of an ideal gas depends only on temperature. (The subscript denotes the quantity kept fixed.) If, on the other hand,  $\Delta Q$  is absorbed at constant pressure,

$$C_p = \left( \frac{\Delta Q}{\Delta T} \right)_p = \left( \frac{\Delta U}{\Delta T} \right)_p + P \left( \frac{\Delta V}{\Delta T} \right)_p \quad (11.10)$$

The subscript  $p$  can be dropped from the first term since  $U$  of an ideal gas depends only on  $T$ . Now, for a mole of an ideal gas

$$PV = RT$$

which gives

$$P \left( \frac{\Delta V}{\Delta T} \right)_p = R \quad (11.11)$$

Equations (11.9) to (11.11) give the desired relation, Eq. (11.8).

## 11.7 THERMODYNAMIC STATE VARIABLES AND EQUATION OF STATE

Every **equilibrium state** of a thermodynamic system is completely described by specific values of some macroscopic variables, also called state variables. For example, an equilibrium state of a gas is completely specified by the values of pressure, volume, temperature, and mass (and composition if there is a mixture of gases). A thermodynamic system is not always in equilibrium. For example, a gas allowed to expand freely against vacuum is not an equilibrium state [Fig. 11.6(a)]. During the rapid expansion, pressure of the gas may

not be uniform throughout. Similarly, a mixture of gases undergoing an explosive chemical reaction (e.g. a mixture of petrol vapour and air when ignited by a spark) is not an equilibrium state; again its temperature and pressure are not uniform [Fig. 11.6(b)]. Eventually, the gas attains a uniform temperature and pressure and comes to thermal and mechanical equilibrium with its surroundings.

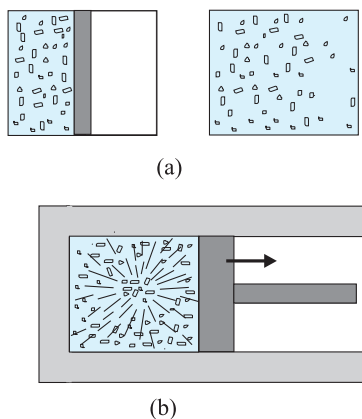

**Fig. 11.6** (a) The partition in the box is suddenly removed leading to free expansion of the gas. (b) A mixture of gases undergoing an explosive chemical reaction. In both situations, the gas is not in equilibrium and cannot be described by state variables.

In short, thermodynamic state variables describe equilibrium states of systems. The various state variables are not necessarily independent. The connection between the state variables is called the equation of state. For example, for an ideal gas, the equation of state is the ideal gas relation

$$PV = \mu RT$$

For a fixed amount of the gas i.e. given  $\mu$ , there are thus, only two independent variables, say  $P$  and  $V$  or  $T$  and  $V$ . The pressure-volume curve for a fixed temperature is called an **isotherm**. Real gases may have more complicated equations of state.

The thermodynamic state variables are of two kinds: **extensive** and **intensive**. Extensive variables indicate the 'size' of the system. Intensive variables such as pressure and

temperature do not. To decide which variable is extensive and which intensive, think of a relevant system in equilibrium, and imagine that it is divided into two equal parts. The variables that remain unchanged for each part are intensive. The variables whose values get halved in each part are extensive. It is easily seen, for example, that internal energy  $U$ , volume  $V$ , total mass  $M$  are extensive variables. Pressure  $P$ , temperature  $T$ , and density  $\rho$  are intensive variables. It is a good practice to check the consistency of thermodynamic equations using this classification of variables. For example, in the equation

$$\Delta Q = \Delta U + P \Delta V$$

quantities on both sides are extensive\*. (The product of an intensive variable like  $P$  and an extensive quantity  $\Delta V$  is extensive.)

## 11.8 THERMODYNAMIC PROCESSES

### 11.8.1 Quasi-static process

Consider a gas in thermal and mechanical equilibrium with its surroundings. The pressure of the gas in that case equals the external pressure and its temperature is the same as that of its surroundings. Suppose that the external pressure is suddenly reduced (say by lifting the weight on the movable piston in the container). The piston will accelerate outward. During the process, the gas passes through states that are not equilibrium states. The non-equilibrium states do not have well-defined pressure and temperature. In the same way, if a finite temperature difference exists between the gas and its surroundings, there will be a rapid exchange of heat during which the gas will pass through non-equilibrium states. In due course, the gas will settle to an equilibrium state with well-defined temperature and pressure equal to those of the surroundings. The free expansion of a gas in vacuum and a mixture of gases undergoing an explosive chemical reaction, mentioned in section 11.7 are also examples where the system goes through non-equilibrium states.

Non-equilibrium states of a system are difficult to deal with. It is, therefore, convenient to imagine an idealised process in which at every stage the system is an equilibrium state. Such a

\* As emphasised earlier,  $Q$  is not a state variable. However,  $\Delta Q$  is clearly proportional to the total mass of system and hence is extensive.

process is, in principle, infinitely slow, hence the name quasi-static (meaning nearly static). The system changes its variables ( $P$ ,  $T$ ,  $V$ ) so slowly that it remains in thermal and mechanical equilibrium with its surroundings throughout. In a quasi-static process, at every stage, the difference in the pressure of the system and the external pressure is infinitesimally small. The same is true of the temperature difference between the system and its surroundings (Fig. 11.7). To take a gas from the state ( $P$ ,  $T$ ) to another state ( $P'$ ,  $T'$ ) via a quasi-static process, we change the external pressure by a very small amount, allow the system to equalise its pressure with that of the surroundings and continue the process infinitely slowly until the system achieves the pressure  $P'$ . Similarly, to change the temperature, we introduce an infinitesimal temperature difference between the system and the surrounding reservoirs and by choosing reservoirs of progressively different temperatures  $T$  to  $T'$ , the system achieves the temperature  $T'$ .

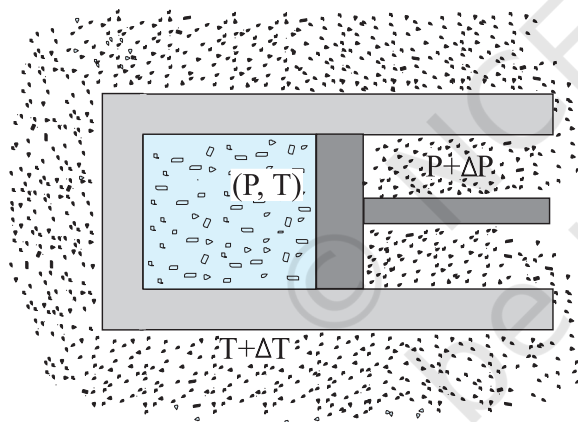

**Fig. 11.7** In a quasi-static process, the temperature of the surrounding reservoir and the external pressure differ only infinitesimally from the temperature and pressure of the system.

A quasi-static process is obviously a hypothetical construct. In practice, processes that are sufficiently slow and do not involve accelerated motion of the piston, large temperature gradient, etc., are reasonably approximation to an ideal quasi-static process. We shall from now on deal with quasi-static processes only, except when stated otherwise.

A process in which the temperature of the system is kept fixed throughout is called an **isothermal process**. The expansion of a gas in a metallic cylinder placed in a large reservoir of fixed temperature is an example of an isothermal process. (Heat transferred from the reservoir to the system does not materially affect the temperature of the reservoir, because of its very large heat capacity.) In **isobaric processes** the pressure is constant while in **isochoric processes** the volume is constant. Finally, if the system is insulated from the surroundings and no heat flows between the system and the surroundings, the process is **adiabatic**. The definitions of these special processes are summarised in Table. 11.2

**Table 11.2** Some special thermodynamic processes

Type of processes	Feature
Isothermal	Temperature constant
Isobaric	Pressure constant
Isochoric	Volume constant
Adiabatic	No heat flow between the system and the surroundings ( $\Delta Q = 0$ )

We now consider these processes in some detail :

### 11.8.2 Isothermal process

For an isothermal process ( $T$  fixed), the ideal gas equation gives

$$PV = \text{constant}$$

i.e., pressure of a given mass of gas varies inversely as its volume. This is nothing but Boyle's Law.

Suppose an ideal gas goes isothermally (at temperature  $T$ ) from its initial state ( $P_1$ ,  $V_1$ ) to the final state ( $P_2$ ,  $V_2$ ). At any intermediate stage with pressure  $P$  and volume change from  $V$  to  $V + \Delta V$  ( $\Delta V$  small)

$$\Delta W = P \Delta V$$

Taking ( $\Delta V \rightarrow 0$ ) and summing the quantity  $\Delta W$  over the entire process,

$$\begin{aligned} W &= \int_{V_1}^{V_2} P \, dV \\ &= \mu RT \int_{V_1}^{V_2} \frac{dV}{V} = \mu RT \ln \frac{V_2}{V_1} \end{aligned} \quad (11.12)$$

where in the second step we have made use of the ideal gas equation  $PV = \mu RT$  and taken the constants out of the integral. For an ideal gas, internal energy depends only on temperature. Thus, there is no change in the internal energy of an ideal gas in an isothermal process. The First Law of Thermodynamics then implies that heat supplied to the gas equals the work done by the gas:  $Q = W$ . Note from Eq. (11.12) that for  $V_2 > V_1$ ,  $W > 0$ ; and for  $V_2 < V_1$ ,  $W < 0$ . That is, in an isothermal expansion, the gas absorbs heat and does work while in an isothermal compression, work is done on the gas by the environment and heat is released.

### 11.8.3 Adiabatic process

In an adiabatic process, the system is insulated from the surroundings and heat absorbed or released is zero. From Eq. (11.1), we see that work done by the gas results in decrease in its internal energy (and hence its temperature for an ideal gas). We quote without proof (the result that you will learn in higher courses) that for an adiabatic process of an ideal gas.

$$P V^\gamma = \text{const} \quad (11.13)$$

where  $\gamma$  is the ratio of specific heats (ordinary or molar) at constant pressure and at constant volume.

$$\gamma = \frac{C_p}{C_v}$$

Thus if an ideal gas undergoes a change in its state adiabatically from  $(P_1, V_1)$  to  $(P_2, V_2)$ :

$$P_1 V_1^\gamma = P_2 V_2^\gamma \quad (11.14)$$

Figure 11.8 shows the  $P$ - $V$  curves of an ideal gas for two adiabatic processes connecting two isotherms.

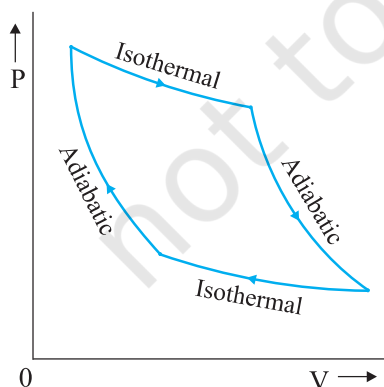

**Fig. 11.8**  $P$ - $V$  curves for isothermal and adiabatic processes of an ideal gas.

We can calculate, as before, the work done in an adiabatic change of an ideal gas from the state  $(P_1, V_1, T_1)$  to the state  $(P_2, V_2, T_2)$ .

$$\begin{aligned} W &= \int_{V_1}^{V_2} P \, dV \\ &= \text{constant} \times \int_{V_1}^{V_2} \frac{dV}{V^\gamma} = \text{constant} \times \frac{V^{-\gamma+1}}{1-\gamma} \Big|_{V_1}^{V_2} \\ &= \frac{\text{constant}}{(1-\gamma)} \times \left[ \frac{1}{V_2^{\gamma-1}} - \frac{1}{V_1^{\gamma-1}} \right] \end{aligned} \quad (11.15)$$

From Eq. (11.14), the constant is  $P_1 V_1^\gamma$  or  $P_2 V_2^\gamma$

$$\begin{aligned} W &= \frac{1}{1-\gamma} \left[ \frac{P_2 V_2^\gamma}{V_2^{\gamma-1}} - \frac{P_1 V_1^\gamma}{V_1^{\gamma-1}} \right] \\ &= \frac{1}{1-\gamma} [P_2 V_2 - P_1 V_1] = \frac{\mu R(T_1 - T_2)}{\gamma - 1} \end{aligned} \quad (11.16)$$

As expected, if work is done by the gas in an adiabatic process ( $W > 0$ ), from Eq. (11.16),  $T_2 < T_1$ . On the other hand, if work is done on the gas ( $W < 0$ ), we get  $T_2 > T_1$  i.e., the temperature of the gas rises.

### 11.8.4 Isochoric process

In an isochoric process,  $V$  is constant. No work is done on or by the gas. From Eq. (11.1), the heat absorbed by the gas goes entirely to change its internal energy and its temperature. The change in temperature for a given amount of heat is determined by the specific heat of the gas at constant volume.

### 11.8.5 Isobaric process

In an isobaric process,  $P$  is fixed. Work done by the gas is

$$W = P(V_2 - V_1) = \mu R(T_2 - T_1) \quad (11.17)$$

Since temperature changes, so does internal energy. The heat absorbed goes partly to increase internal energy and partly to do work. The change in temperature for a given amount of heat is determined by the specific heat of the gas at constant pressure.

### 11.8.6 Cyclic process

In a cyclic process, the system returns to its initial state. Since internal energy is a state variable,  $\Delta U = 0$  for a cyclic process. From

Eq. (11.1), the total heat absorbed equals the work done by the system.

### 11.9 SECOND LAW OF THERMODYNAMICS

The First Law of Thermodynamics is the principle of conservation of energy. Common experience shows that there are many conceivable processes that are perfectly allowed by the First Law and yet are never observed. For example, nobody has ever seen a book lying on a table jumping to a height by itself. But such a thing would be possible if the principle of conservation of energy were the only restriction. The table could cool spontaneously, converting some of its internal energy into an equal amount of mechanical energy of the book, which would then hop to a height with potential energy equal to the mechanical energy it acquired. But this never happens. Clearly, some additional basic principle of nature forbids the above, even though it satisfies the energy conservation principle. This principle, which disallows many phenomena consistent with the First Law of Thermodynamics is known as the Second Law of Thermodynamics.

The Second Law of Thermodynamics gives a fundamental limitation to the efficiency of a heat engine and the co-efficient of performance of a refrigerator. In simple terms, it says that efficiency of a heat engine can never be unity. For a refrigerator, the Second Law says that the co-efficient of performance can never be infinite. The following two statements, one due to Kelvin and Planck denying the possibility of a perfect heat engine, and another due to Clausius denying the possibility of a perfect refrigerator or heat pump, are a concise summary of these observations.

#### **Kelvin-Planck statement**

No process is possible whose sole result is the absorption of heat from a reservoir and the complete conversion of the heat into work.

#### **Clausius statement**

No process is possible whose sole result is the transfer of heat from a colder object to a hotter object.

It can be proved that the two statements above are completely equivalent.

### 11.10 REVERSIBLE AND IRREVERSIBLE PROCESSES

Imagine some process in which a thermodynamic system goes from an initial state  $i$  to a final state  $f$ . During the process the system absorbs heat  $Q$  from the surroundings and performs work  $W$  on it. Can we reverse this process and bring both the system and surroundings to their initial states with no other effect anywhere? Experience suggests that for most processes in nature this is not possible. The spontaneous processes of nature are irreversible. Several examples can be cited. The base of a vessel on an oven is hotter than its other parts. When the vessel is removed, heat is transferred from the base to the other parts, bringing the vessel to a uniform temperature (which in due course cools to the temperature of the surroundings). The process cannot be reversed; a part of the vessel will not get cooler spontaneously and warm up the base. It will violate the Second Law of Thermodynamics, if it did. The free expansion of a gas is irreversible. The combustion reaction of a mixture of petrol and air ignited by a spark cannot be reversed. Cooking gas leaking from a gas cylinder in the kitchen diffuses to the entire room. The diffusion process will not spontaneously reverse and bring the gas back to the cylinder. The stirring of a liquid in thermal contact with a reservoir will convert the work done into heat, increasing the internal energy of the reservoir. The process cannot be reversed exactly; otherwise it would amount to conversion of heat entirely into work, violating the Second Law of Thermodynamics. Irreversibility is a rule rather an exception in nature.

Irreversibility arises mainly from two causes: one, many processes (like a free expansion, or an explosive chemical reaction) take the system to non-equilibrium states; two, most processes involve friction, viscosity and other dissipative effects (e.g., a moving body coming to a stop and losing its mechanical energy as heat to the floor and the body; a rotating blade in a liquid coming to a stop due to viscosity and losing its mechanical energy with corresponding gain in the internal energy of the liquid). Since dissipative effects are present everywhere and can be minimised but not fully eliminated, most processes that we deal with are irreversible.

A thermodynamic process (state  $i \rightarrow$  state  $f$ ) is reversible if the process can be turned back such that both the system and the surroundings return to their original states, with no other change anywhere else in the universe. From the preceding discussion, a reversible process is an idealised notion. A process is reversible only if it is quasi-static (system in equilibrium with the surroundings at every stage) and there are no dissipative effects. For example, a quasi-static isothermal expansion of an ideal gas in a cylinder fitted with a frictionless movable piston is a reversible process.

Why is reversibility such a basic concept in thermodynamics? As we have seen, one of the concerns of thermodynamics is the efficiency with which heat can be converted into work. The Second Law of Thermodynamics rules out the possibility of a perfect heat engine with 100% efficiency. But what is the highest efficiency possible for a heat engine working between two reservoirs at temperatures  $T_1$  and  $T_2$ ? It turns out that a heat engine based on idealised reversible processes achieves the highest efficiency possible. All other engines involving irreversibility in any way (as would be the case for practical engines) have lower than this limiting efficiency.

### 11.11 CARNOT ENGINE

Suppose we have a hot reservoir at temperature  $T_1$  and a cold reservoir at temperature  $T_2$ . What is the maximum efficiency possible for a heat engine operating between the two reservoirs and what cycle of processes should be adopted to achieve the maximum efficiency? Sadi Carnot, a French engineer, first considered this question in 1824. Interestingly, Carnot arrived at the correct answer, even though the basic concepts of heat and thermodynamics had yet to be firmly established.

We expect the ideal engine operating between two temperatures to be a reversible engine. Irreversibility is associated with dissipative effects, as remarked in the preceding section, and lowers efficiency. A process is reversible if it is quasi-static and non-dissipative. We have seen that a process is not quasi-static if it involves finite temperature difference between the system and the reservoir. This implies that

in a reversible heat engine operating between two temperatures, heat should be absorbed (from the hot reservoir) isothermally and released (to the cold reservoir) isothermally. We thus have identified two steps of the reversible heat engine: isothermal process at temperature  $T_1$  absorbing heat  $Q_1$  from the hot reservoir, and another isothermal process at temperature  $T_2$  releasing heat  $Q_2$  to the cold reservoir. To complete a cycle, we need to take the system from temperature  $T_1$  to  $T_2$  and then back from temperature  $T_2$  to  $T_1$ . Which processes should we employ for this purpose that are reversible? A little reflection shows that we can only adopt reversible adiabatic processes for these purposes, which involve no heat flow from any reservoir. If we employ any other process that is not adiabatic, say an isochoric process, to take the system from one temperature to another, we shall need a series of reservoirs in the temperature range  $T_2$  to  $T_1$  to ensure that at each stage the process is quasi-static. (Remember again that for a process to be quasi-static and reversible, there should be no finite temperature difference between the system and the reservoir.) But we are considering a reversible engine that operates between only two temperatures. Thus adiabatic processes must bring about the temperature change in the system from  $T_1$  to  $T_2$  and  $T_2$  to  $T_1$  in this engine.

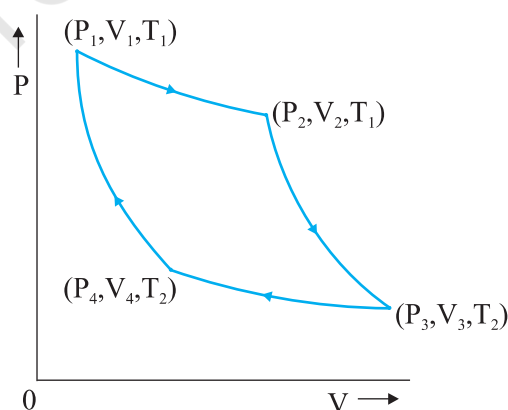

**Fig. 11.9** Carnot cycle for a heat engine with an ideal gas as the working substance.

A reversible heat engine operating between two temperatures is called a Carnot engine. We have just argued that such an engine must have the following sequence of steps constituting one

cycle, called the Carnot cycle, shown in Fig. 11.9. We have taken the working substance of the Carnot engine to be an ideal gas.

- (a) *Step 1*  $\rightarrow$  2 Isothermal expansion of the gas taking its state from  $(P_1, V_1, T_1)$  to  $(P_2, V_2, T_1)$ .

The heat absorbed by the gas ( $\mathcal{Q}_1$ ) from the reservoir at temperature  $T_1$  is given by Eq. (11.12). This is also the work done ( $W_{1 \rightarrow 2}$ ) by the gas on the environment.

$$W_{1 \rightarrow 2} = \mathcal{Q}_1 = \mu R T_1 \ln \left( \frac{V_2}{V_1} \right) \quad (11.18)$$

- (b) *Step 2*  $\rightarrow$  3 Adiabatic expansion of the gas from  $(P_2, V_2, T_1)$  to  $(P_3, V_3, T_2)$ . Work done by the gas, using Eq. (11.16), is

$$W_{2 \rightarrow 3} = \frac{\mu R (T_1 - T_2)}{\gamma - 1} \quad (11.19)$$

- (c) *Step 3*  $\rightarrow$  4 Isothermal compression of the gas from  $(P_3, V_3, T_2)$  to  $(P_4, V_4, T_2)$ .

Heat released ( $\mathcal{Q}_2$ ) by the gas to the reservoir at temperature  $T_2$  is given by Eq. (11.12). This is also the work done ( $W_{3 \rightarrow 4}$ ) on the gas by the environment.

$$W_{3 \rightarrow 4} = \mathcal{Q}_2 = \mu R T_2 \ln \left( \frac{V_3}{V_4} \right) \quad (11.20)$$

- (d) *Step 4*  $\rightarrow$  1 Adiabatic compression of the gas from  $(P_4, V_4, T_2)$  to  $(P_1, V_1, T_1)$ .

Work done on the gas, [using Eq.(11.16), is

$$W_{4 \rightarrow 1} = \mu R \left( \frac{T_1 - T_2}{\gamma - 1} \right) \quad (11.21)$$

From Eqs. (11.18) to (11.21) total work done by the gas in one complete cycle is

$$\begin{aligned} W &= W_{1 \rightarrow 2} + W_{2 \rightarrow 3} - W_{3 \rightarrow 4} - W_{4 \rightarrow 1} \\ &= \mu R T_1 \ln \left( \frac{V_2}{V_1} \right) - \mu R T_2 \ln \left( \frac{V_3}{V_4} \right) \end{aligned} \quad (11.22)$$

The efficiency  $\eta$  of the Carnot engine is

$$\eta = \frac{W}{\mathcal{Q}_1} = 1 - \frac{\mathcal{Q}_2}{\mathcal{Q}_1}$$

$$= 1 - \left( \frac{T_2}{T_1} \right) \frac{\ln \left( \frac{V_3}{V_4} \right)}{\ln \left( \frac{V_2}{V_1} \right)} \quad (11.23)$$

Now since step 2  $\rightarrow$  3 is an adiabatic process,

$$T_1 V_2^{\gamma-1} = T_2 V_3^{\gamma-1}$$

$$\text{i.e. } \frac{V_2}{V_3} = \left( \frac{T_2}{T_1} \right)^{1/(\gamma-1)} \quad (11.24)$$

Similarly, since step 4  $\rightarrow$  1 is an adiabatic process

$$T_2 V_4^{\gamma-1} = T_1 V_1^{\gamma-1}$$

$$\text{i.e. } \frac{V_1}{V_4} = \left( \frac{T_2}{T_1} \right)^{1/\gamma-1} \quad (11.25)$$

From Eqs. (11.24) and (11.25),

$$\frac{V_3}{V_4} = \frac{V_2}{V_1} \quad (11.26)$$

Using Eq. (11.26) in Eq. (11.23), we get

$$\eta = 1 - \frac{T_2}{T_1} \quad (\text{Carnot engine}) \quad (11.27)$$

We have already seen that a Carnot engine is a reversible engine. Indeed it is the only reversible engine possible that works between two reservoirs at different temperatures. Each step of the Carnot cycle given in Fig. 11.9 can be reversed. This will amount to taking heat  $\mathcal{Q}_2$  from the cold reservoir at  $T_2$ , doing work  $W$  on the system, and transferring heat  $\mathcal{Q}_1$  to the hot reservoir. This will be a reversible refrigerator.

We next establish the important result (sometimes called Carnot's theorem) that (a) working between two given temperatures  $T_1$  and  $T_2$  of the hot and cold reservoirs respectively, no engine can have efficiency more than that of the Carnot engine and (b) the efficiency of the Carnot engine is independent of the nature of the working substance.

To prove the result (a), imagine a reversible (Carnot) engine  $R$  and an irreversible engine  $I$  working between the same source (hot reservoir) and sink (cold reservoir). Let us couple the engines,  $I$  and  $R$ , in such a way so that  $I$  acts like a heat engine and  $R$  acts as a refrigerator. Let  $I$  absorb heat  $Q_1$  from the source, deliver work  $W'$  and release the heat  $Q_1 - W'$  to the sink. We arrange so that  $R$  returns the same heat  $Q_1$  to the source, taking heat  $Q_2$  from the sink and requiring work  $W = Q_1 - Q_2$  to be done on it. Now suppose  $\eta_R < \eta_I$  i.e. if  $R$  were to act as an engine it would give less work output

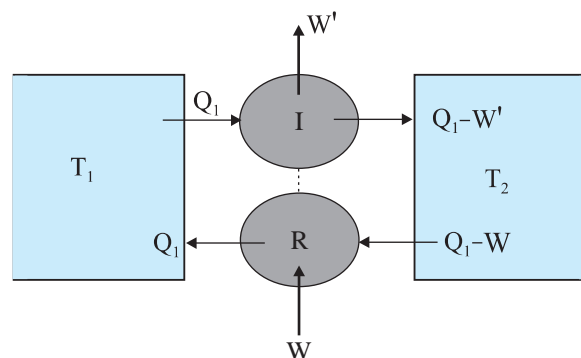

**Fig. 11.10** An irreversible engine ( $I$ ) coupled to a reversible refrigerator ( $R$ ). If  $W' > W$ , this would amount to extraction of heat  $W' - W$  from the sink and its full conversion to work, in contradiction with the Second Law of Thermodynamics.

than that of  $I$  i.e.  $W < W'$  for a given  $Q_1$ . With  $R$  acting like a refrigerator, this would mean  $Q_2 = Q_1 - W > Q_1 - W'$ . Thus, on the whole, the coupled  $I$ - $R$  system extracts heat  $(Q_1 - W) - (Q_1 - W') = (W' - W)$  from the cold

reservoir and delivers the same amount of work in one cycle, without any change in the source or anywhere else. This is clearly against the Kelvin-Planck statement of the Second Law of Thermodynamics. Hence the assertion  $\eta_I > \eta_R$  is wrong. No engine can have efficiency greater than that of the Carnot engine. A similar argument can be constructed to show that a reversible engine with one particular substance cannot be more efficient than the one using another substance. The maximum efficiency of a Carnot engine given by Eq. (11.27) is independent of the nature of the system performing the Carnot cycle of operations. Thus we are justified in using an ideal gas as a system in the calculation of efficiency  $\eta$  of a Carnot engine. The ideal gas has a simple equation of state, which allows us to readily calculate  $\eta$ , but the final result for  $\eta$ , [Eq. (11.27)], is true for any Carnot engine.

This final remark shows that in a Carnot cycle,

$$\frac{Q_1}{Q_2} = \frac{T_1}{T_2} \quad (11.28)$$

is a universal relation independent of the nature of the system. Here  $Q_1$  and  $Q_2$  are respectively, the heat absorbed and released isothermally (from the hot and to the cold reservoirs) in a Carnot engine. Equation (11.28), can, therefore, be used as a relation to define a truly universal thermodynamic temperature scale that is independent of any particular properties of the system used in the Carnot cycle. Of course, for an ideal gas as a working substance, this universal temperature is the same as the ideal gas temperature introduced in section 11.9.

### SUMMARY

1. The zeroth law of thermodynamics states that 'two systems in thermal equilibrium with a third system separately are in thermal equilibrium with each other'. The Zeroth Law leads to the concept of temperature.
2. Internal energy of a system is the sum of kinetic energies and potential energies of the molecular constituents of the system. It does not include the over-all kinetic energy of the system. Heat and work are two modes of energy transfer to the system. Heat is the energy transfer arising due to temperature difference between the system and the surroundings. Work is energy transfer brought about by other means, such as moving the piston of a cylinder containing the gas, by raising or lowering some weight connected to it.



3. The first law of thermodynamics is the general law of conservation of energy applied to any system in which energy transfer from or to the surroundings (through heat and work) is taken into account. It states that

$$\Delta Q = \Delta U + \Delta W$$

where  $\Delta Q$  is the heat supplied to the system,  $\Delta W$  is the work done by the system and  $\Delta U$  is the change in internal energy of the system.

4. The specific heat capacity of a substance is defined by

$$s = \frac{1}{m} \frac{\Delta Q}{\Delta T}$$

where  $m$  is the mass of the substance and  $\Delta Q$  is the heat required to change its temperature by  $\Delta T$ . The molar specific heat capacity of a substance is defined by

$$C = \frac{1}{\mu} \frac{\Delta Q}{\Delta T}$$

where  $\mu$  is the number of moles of the substance. For a solid, the law of equipartition of energy gives

$$C = 3R$$

which generally agrees with experiment at ordinary temperatures.

Calorie is the old unit of heat. 1 calorie is the amount of heat required to raise the temperature of 1 g of water from 14.5 °C to 15.5 °C. 1 cal = 4.186 J.

5. For an ideal gas, the molar specific heat capacities at constant pressure and volume satisfy the relation

$$C_p - C_v = R$$

where  $R$  is the universal gas constant.

6. Equilibrium states of a thermodynamic system are described by state variables. The value of a state variable depends only on the particular state, not on the path used to arrive at that state. Examples of state variables are pressure ( $P$ ), volume ( $V$ ), temperature ( $T$ ), and mass ( $m$ ). Heat and work are not state variables. An Equation of State (like the ideal gas equation  $PV = \mu RT$ ) is a relation connecting different state variables.
7. A quasi-static process is an infinitely slow process such that the system remains in thermal and mechanical equilibrium with the surroundings throughout. In a quasi-static process, the pressure and temperature of the environment can differ from those of the system only infinitesimally.
8. In an isothermal expansion of an ideal gas from volume  $V_1$  to  $V_2$  at temperature  $T$  the heat absorbed ( $Q$ ) equals the work done ( $W$ ) by the gas, each given by

$$Q = W = \mu R T \ln \left( \frac{V_2}{V_1} \right)$$

9. In an adiabatic process of an ideal gas

$$PV^\gamma = \text{constant}$$

where

$$\gamma = \frac{C_p}{C_v}$$

Work done by an ideal gas in an adiabatic change of state from  $(P_1, V_1, T_1)$  to  $(P_2, V_2, T_2)$  is

$$W = \frac{\mu R (T_1 - T_2)}{\gamma - 1}$$

10. The second law of thermodynamics disallows some processes consistent with the First Law of Thermodynamics. It states

*Kelvin-Planck statement*

No process is possible whose sole result is the absorption of heat from a reservoir and complete conversion of the heat into work.

*Clausius statement*

No process is possible whose sole result is the transfer of heat from a colder object to a hotter object.

Put simply, the Second Law implies that no heat engine can have efficiency  $\eta$  equal to 1 or no refrigerator can have co-efficient of performance  $\alpha$  equal to infinity.

11. A process is reversible if it can be reversed such that both the system and the surroundings return to their original states, with no other change anywhere else in the universe. Spontaneous processes of nature are irreversible. The idealised reversible process is a quasi-static process with no dissipative factors such as friction, viscosity, etc.
12. Carnot engine is a reversible engine operating between two temperatures  $T_1$  (source) and  $T_2$  (sink). The Carnot cycle consists of two isothermal processes connected by two adiabatic processes. The efficiency of a Carnot engine is given by

$$\eta = 1 - \frac{T_2}{T_1} \quad (\text{Carnot engine})$$

No engine operating between two temperatures can have efficiency greater than that of the Carnot engine.

13. If  $Q > 0$ , heat is added to the system  
 If  $Q < 0$ , heat is removed to the system  
 If  $W > 0$ , Work is done by the system  
 If  $W < 0$ , Work is done on the system

Quantity	Symbol	Dimensions	Unit	Remark
Co-efficiency of volume expansion	$\alpha_v$	$[K^{-1}]$	$K^{-1}$	$\alpha_v = 3 \alpha_1$
Heat supplied to a system	$\Delta Q$	$[ML^2 T^{-2}]$	J	$Q$ is not a state variable
Specific heat capacity	$s$	$[L^2 T^{-2} K^{-1}]$	$J \text{ kg}^{-1} K^{-1}$	
Thermal Conductivity	$K$	$[MLT^{-3} K^{-1}]$	$J \text{ s}^{-1} K^{-1}$	$H = -KA \frac{dt}{dx}$

#### POINTS TO PONDER

1. Temperature of a body is related to its average internal energy, not to the kinetic energy of motion of its centre of mass. A bullet fired from a gun is not at a higher temperature because of its high speed.
2. Equilibrium in thermodynamics refers to the situation when macroscopic variables describing the thermodynamic state of a system do not depend on time. Equilibrium of a system in mechanics means the net external force and torque on the system are zero.

3. In a state of thermodynamic equilibrium, the microscopic constituents of a system are not in equilibrium (in the sense of mechanics).
4. Heat capacity, in general, depends on the process the system goes through when heat is supplied.
5. In isothermal quasi-static processes, heat is absorbed or given out by the system even though at every stage the gas has the same temperature as that of the surrounding reservoir. This is possible because of the infinitesimal difference in temperature between the system and the reservoir.

### EXERCISES

- 11.1 A geyser heats water flowing at the rate of 3.0 litres per minute from 27 °C to 77 °C. If the geyser operates on a gas burner, what is the rate of consumption of the fuel if its heat of combustion is  $4.0 \times 10^4$  J/g ?
- 11.2 What amount of heat must be supplied to  $2.0 \times 10^{-2}$  kg of nitrogen (at room temperature) to raise its temperature by 45 °C at constant pressure ? (Molecular mass of  $N_2 = 28$ ;  $R = 8.3$  J mol<sup>-1</sup> K<sup>-1</sup>.)
- 11.3 Explain why
  - (a) Two bodies at different temperatures  $T_1$  and  $T_2$  if brought in thermal contact do not necessarily settle to the mean temperature  $(T_1 + T_2)/2$ .
  - (b) The coolant in a chemical or a nuclear plant (i.e., the liquid used to prevent the different parts of a plant from getting too hot) should have high specific heat.
  - (c) Air pressure in a car tyre increases during driving.
  - (d) The climate of a harbour town is more temperate than that of a town in a desert at the same latitude.
- 11.4 A cylinder with a movable piston contains 3 moles of hydrogen at standard temperature and pressure. The walls of the cylinder are made of a heat insulator, and the piston is insulated by having a pile of sand on it. By what factor does the pressure of the gas increase if the gas is compressed to half its original volume ?
- 11.5 In changing the state of a gas adiabatically from an equilibrium state  $A$  to another equilibrium state  $B$ , an amount of work equal to 22.3 J is done on the system. If the gas is taken from state  $A$  to  $B$  via a process in which the net heat absorbed by the system is 9.35 cal, how much is the net work done by the system in the latter case ? (Take 1 cal = 4.19 J)
- 11.6 Two cylinders  $A$  and  $B$  of equal capacity are connected to each other via a stopcock.  $A$  contains a gas at standard temperature and pressure.  $B$  is completely evacuated. The entire system is thermally insulated. The stopcock is suddenly opened. Answer the following :
  - (a) What is the final pressure of the gas in  $A$  and  $B$  ?
  - (b) What is the change in internal energy of the gas ?
  - (c) What is the change in the temperature of the gas ?
  - (d) Do the intermediate states of the system (before settling to the final equilibrium state) lie on its  $P$ - $V$ - $T$  surface ?
- 11.7 An electric heater supplies heat to a system at a rate of 100W. If system performs work at a rate of 75 joules per second. At what rate is the internal energy increasing?

- 11.8** A thermodynamic system is taken from an original state to an intermediate state by the linear process shown in Fig. (11.13)

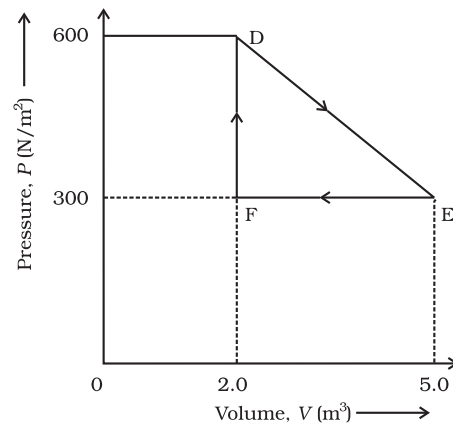

**Fig. 11.11**

Its volume is then reduced to the original value from E to F by an isobaric process. Calculate the total work done by the gas from D to E to F



## KINETIC THEORY

- 12.1 Introduction
  - 12.2 Molecular nature of matter
  - 12.3 Behaviour of gases
  - 12.4 Kinetic theory of an ideal gas
  - 12.5 Law of equipartition of energy
  - 12.6 Specific heat capacity
  - 12.7 Mean free path
- Summary  
Points to ponder  
Exercises

### 12.1 INTRODUCTION

Boyle discovered the law named after him in 1661. Boyle, Newton and several others tried to explain the behaviour of gases by considering that gases are made up of tiny atomic particles. The actual atomic theory got established more than 150 years later. Kinetic theory explains the behaviour of gases based on the idea that the gas consists of rapidly moving atoms or molecules. This is possible as the inter-atomic forces, which are short range forces that are important for solids and liquids, can be neglected for gases. The kinetic theory was developed in the nineteenth century by Maxwell, Boltzmann and others. It has been remarkably successful. It gives a molecular interpretation of pressure and temperature of a gas, and is consistent with gas laws and Avogadro's hypothesis. It correctly explains specific heat capacities of many gases. It also relates measurable properties of gases such as viscosity, conduction and diffusion with molecular parameters, yielding estimates of molecular sizes and masses. This chapter gives an introduction to kinetic theory.

### 12.2 MOLECULAR NATURE OF MATTER

Richard Feynman, one of the great physicists of 20th century considers the discovery that "Matter is made up of atoms" to be a very significant one. Humanity may suffer annihilation (due to nuclear catastrophe) or extinction (due to environmental disasters) if we do not act wisely. If that happens, and all of scientific knowledge were to be destroyed then Feynman would like the 'Atomic Hypothesis' to be communicated to the next generation of creatures in the universe. Atomic Hypothesis: All things are made of atoms - little particles that move around in perpetual motion, attracting each other when they are a little distance apart, but repelling upon being squeezed into one another.

Speculation that matter may not be continuous, existed in many places and cultures. Kanada in India and Democritus

### *Atomic Hypothesis in Ancient India and Greece*

Though John Dalton is credited with the introduction of atomic viewpoint in modern science, scholars in ancient India and Greece conjectured long before the existence of atoms and molecules. In the Vaiseshika school of thought in India founded by Kanada (Sixth century B.C.) the atomic picture was developed in considerable detail. Atoms were thought to be eternal, indivisible, infinitesimal and ultimate parts of matter. It was argued that if matter could be subdivided without an end, there would be no difference between a mustard seed and the Meru mountain. The four kinds of atoms (**Paramanu** — Sanskrit word for the smallest particle) postulated were Bhoomi (Earth), Ap (water), Tejas (fire) and Vayu (air) that have characteristic mass and other attributes, were propounded. Akasa (space) was thought to have no atomic structure and was continuous and inert. Atoms combine to form different molecules (e.g. two atoms combine to form a diatomic molecule *dyanuka*, three atoms form a *tryanuka* or a triatomic molecule), their properties depending upon the nature and ratio of the constituent atoms. The size of the atoms was also estimated, by conjecture or by methods that are not known to us. The estimates vary. In *Lalitavistara*, a famous biography of the Buddha written mainly in the second century B.C., the estimate is close to the modern estimate of atomic size, of the order of  $10^{-10}$  m.

In ancient Greece, Democritus (Fourth century B.C.) is best known for his atomic hypothesis. The word 'atom' means 'indivisible' in Greek. According to him, atoms differ from each other physically, in shape, size and other properties and this resulted in the different properties of the substances formed by their combination. The atoms of water were smooth and round and unable to 'hook' on to each other, which is why liquid /water flows easily. The atoms of earth were rough and jagged, so they held together to form hard substances. The atoms of fire were thorny which is why it caused painful burns. These fascinating ideas, despite their ingenuity, could not evolve much further, perhaps because they were intuitive conjectures and speculations not tested and modified by quantitative experiments - the hallmark of modern science.

in Greece had suggested that matter may consist of indivisible constituents. The scientific 'Atomic Theory' is usually credited to John Dalton. He proposed the atomic theory to explain the laws of definite and multiple proportions obeyed by elements when they combine into compounds. The first law says that any given compound has, a fixed proportion by mass of its constituents. The second law says that when two elements form more than one compound, for a fixed mass of one element, the masses of the other elements are in ratio of small integers.

To explain the laws Dalton suggested, about 200 years ago, that the smallest constituents of an element are atoms. Atoms of one element are identical but differ from those of other elements. A small number of atoms of each element combine to form a molecule of the compound. Gay Lussac's law, also given in early 19<sup>th</sup> century, states: When gases combine chemically to yield another gas, their volumes are in the ratios of small integers. Avogadro's law (or hypothesis) says: Equal volumes of all gases at equal temperature and pressure have the same number of molecules. Avogadro's law, when combined with Dalton's theory explains Gay Lussac's law. Since the elements are often in the form of molecules, Dalton's atomic theory can also be referred to as the molecular theory

of matter. The theory is now well accepted by scientists. However even at the end of the nineteenth century there were famous scientists who did not believe in atomic theory !

From many observations, in recent times we now know that molecules (made up of one or more atoms) constitute matter. Electron microscopes and scanning tunnelling microscopes enable us to even see them. The size of an atom is about an angstrom ( $10^{-10}$  m). In solids, which are tightly packed, atoms are spaced about a few angstroms (2 Å) apart. In liquids the separation between atoms is also about the same. In liquids the atoms are not as rigidly fixed as in solids, and can move around. This enables a liquid to flow. In gases the interatomic distances are in tens of angstroms. The average distance a molecule can travel without colliding is called the **mean free path**. The mean free path, in gases, is of the order of thousands of angstroms. The atoms are much freer in gases and can travel long distances without colliding. If they are not enclosed, gases disperse away. In solids and liquids the closeness makes the interatomic force important. The force has a long range attraction and a short range repulsion. The atoms attract when they are at a few angstroms but repel when they come closer. The static appearance of a gas

is misleading. The gas is full of activity and the equilibrium is a dynamic one. In dynamic equilibrium, molecules collide and change their speeds during the collision. Only the average properties are constant.

Atomic theory is not the end of our quest, but the beginning. We now know that atoms are not indivisible or elementary. They consist of a nucleus and electrons. The nucleus itself is made up of protons and neutrons. The protons and neutrons are again made up of quarks. Even quarks may not be the end of the story. There may be string like elementary entities. Nature always has surprises for us, but the search for truth is often enjoyable and the discoveries beautiful. In this chapter, we shall limit ourselves to understanding the behaviour of gases (and a little bit of solids), as a collection of moving molecules in incessant motion.

### 12.3 BEHAVIOUR OF GASES

Properties of gases are easier to understand than those of solids and liquids. This is mainly because in a gas, molecules are far from each other and their mutual interactions are negligible except when two molecules collide. Gases at low pressures and high temperatures much above that at which they liquefy (or solidify) approximately satisfy a simple relation between their pressure, temperature and volume given by (see Chapter 10)

$$PV = KT \quad (12.1)$$

for a given sample of the gas. Here  $T$  is the temperature in kelvin or (absolute) scale.  $K$  is a constant for the given sample but varies with the volume of the gas. If we now bring in the idea of atoms or molecules, then  $K$  is proportional to the number of molecules, (say)  $N$  in the sample. We can write  $K = Nk$ . Observation tells us that this  $k$  is same for all gases. It is called Boltzmann constant and is denoted by  $k_B$ .

$$\text{As } \frac{P_1 V_1}{N_1 T_1} = \frac{P_2 V_2}{N_2 T_2} = \text{constant} = k_B \quad (12.2)$$

if  $P$ ,  $V$  and  $T$  are same, then  $N$  is also same for all gases. This is Avogadro's hypothesis, that the number of molecules per unit volume is the same for all gases at a fixed temperature and pressure. The number in 22.4 litres of any gas

is  $6.02 \times 10^{23}$ . This is known as Avogadro number and is denoted by  $N_A$ . The mass of 22.4 litres of any gas is equal to its molecular weight in grams at S.T.P (standard temperature 273 K and pressure 1 atm). This amount of substance is called a mole (see Chapter 1 for a more precise definition). Avogadro had guessed the equality of numbers in equal volumes of gas at a fixed temperature and pressure from chemical reactions. Kinetic theory justifies this hypothesis.

The perfect gas equation can be written as

$$PV = \mu RT \quad (12.3)$$

where  $\mu$  is the number of moles and  $R = N_A k_B$  is a universal constant. The temperature  $T$  is absolute temperature. Choosing kelvin scale for absolute temperature,  $R = 8.314 \text{ J mol}^{-1} \text{K}^{-1}$ . Here

$$\mu = \frac{M}{M_0} = \frac{N}{N_A} \quad (12.4)$$

where  $M$  is the mass of the gas containing  $N$  molecules,  $M_0$  is the molar mass and  $N_A$  the Avogadro's number. Using Eqs. (12.4) and (12.3) can also be written as

$$PV = k_B NT \quad \text{or} \quad P = k_B nT$$

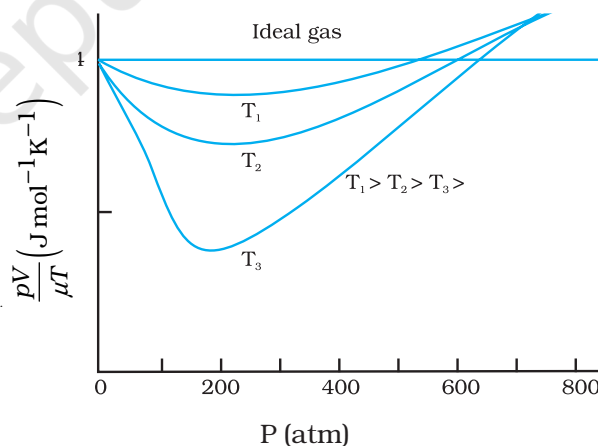

**Fig. 12.1** Real gases approach ideal gas behaviour at low pressures and high temperatures.

where  $n$  is the number density, i.e. number of molecules per unit volume.  $k_B$  is the Boltzmann constant introduced above. Its value in SI units is  $1.38 \times 10^{-23} \text{ J K}^{-1}$ .

Another useful form of Eq. (12.3) is

$$P = \frac{\rho RT}{M_0} \quad (12.5)$$

where  $\rho$  is the mass density of the gas.

A gas that satisfies Eq. (12.3) exactly at all pressures and temperatures is defined to be an **ideal gas**. An ideal gas is a simple theoretical model of a gas. No real gas is truly ideal. Fig. 12.1 shows departures from ideal gas behaviour for a real gas at three different temperatures. Notice that all curves approach the ideal gas behaviour for low pressures and high temperatures.

At low pressures or high temperatures the molecules are far apart and molecular interactions are negligible. Without interactions the gas behaves like an ideal one.

If we fix  $\mu$  and  $T$  in Eq. (12.3), we get

$$PV = \text{constant} \tag{12.6}$$

i.e., keeping temperature constant, pressure of a given mass of gas varies inversely with volume. This is the famous **Boyle's law**. Fig. 12.2 shows comparison between experimental  $P$ - $V$  curves and the theoretical curves predicted by Boyle's law. Once again you see that the agreement is good at high temperatures and low pressures. Next, if you fix  $P$ , Eq. (12.1) shows that  $V \propto T$  i.e., for a fixed pressure, the volume of a gas is proportional to its absolute temperature  $T$  (**Charles' law**). See Fig. 12.3.

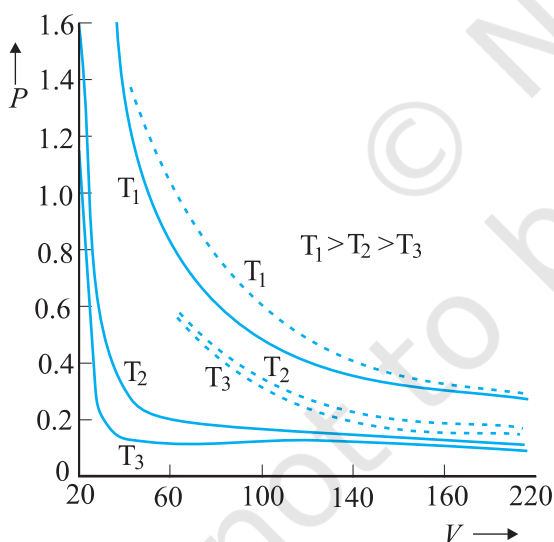

**Fig. 12.2** Experimental  $P$ - $V$  curves (solid lines) for steam at three temperatures compared with Boyle's law (dotted lines).  $P$  is in units of 22 atm and  $V$  in units of 0.09 litres.

Finally, consider a mixture of non-interacting ideal gases:  $\mu_1$  moles of gas 1,  $\mu_2$  moles of gas 2,

etc. in a vessel of volume  $V$  at temperature  $T$  and pressure  $P$ . It is then found that the equation of state of the mixture is :

$$PV = (\mu_1 + \mu_2 + \dots) RT \tag{12.7}$$

$$\text{i.e. } P = \mu_1 \frac{RT}{V} + \mu_2 \frac{RT}{V} + \dots \tag{12.8}$$

$$= P_1 + P_2 + \dots \tag{12.9}$$

Clearly  $P_1 = \mu_1 RT/V$  is the pressure that gas 1 would exert at the same conditions of volume and temperature if no other gases were present. This is called the partial pressure of the gas. Thus, the total pressure of a mixture of ideal gases is the sum of partial pressures. This is Dalton's law of partial pressures.

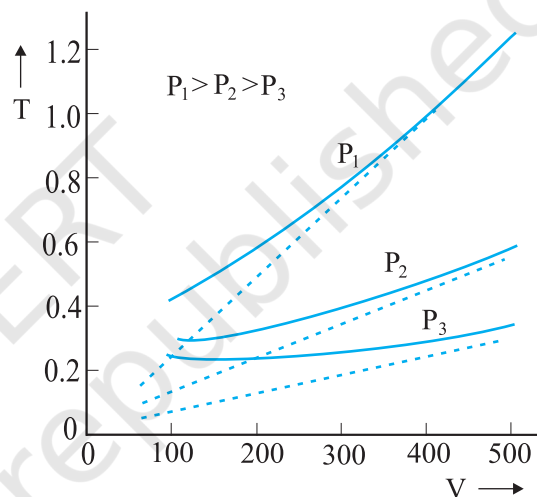

**Fig. 12.3** Experimental  $T$ - $V$  curves (solid lines) for  $\text{CO}_2$  at three pressures compared with Charles' law (dotted lines).  $T$  is in units of 300 K and  $V$  in units of 0.13 litres.

We next consider some examples which give us information about the volume occupied by the molecules and the volume of a single molecule.

**Example 12.1** The density of water is  $1000 \text{ kg m}^{-3}$ . The density of water vapour at  $100^\circ\text{C}$  and 1 atm pressure is  $0.6 \text{ kg m}^{-3}$ . The volume of a molecule multiplied by the total number gives what is called, molecular volume. Estimate the ratio (or fraction) of the molecular volume to the total volume occupied by the water vapour under the above conditions of temperature and pressure.



**Answer** For a given mass of water molecules, the density is less if volume is large. So the volume of the vapour is  $1000/0.6 = 1/(6 \times 10^{-4})$  times larger. If densities of bulk water and water molecules are same, then the fraction of molecular volume to the total volume in liquid state is 1. As volume in vapour state has increased, the fractional volume is less by the same amount, i.e.  $6 \times 10^{-4}$ .

► **Example 12.2** Estimate the volume of a water molecule using the data in Example 12.1.

**Answer** In the liquid (or solid) phase, the molecules of water are quite closely packed. The density of water molecule may therefore, be regarded as roughly equal to the density of bulk water =  $1000 \text{ kg m}^{-3}$ . To estimate the volume of a water molecule, we need to know the mass of a single water molecule. We know that 1 mole of water has a mass approximately equal to

$$(2 + 16)\text{g} = 18 \text{ g} = 0.018 \text{ kg.}$$

Since 1 mole contains about  $6 \times 10^{23}$  molecules (Avogadro's number), the mass of a molecule of water is  $(0.018)/(6 \times 10^{23}) \text{ kg} = 3 \times 10^{-26} \text{ kg}$ . Therefore, a rough estimate of the volume of a water molecule is as follows :

$$\begin{aligned} \text{Volume of a water molecule} &= (3 \times 10^{-26} \text{ kg}) / (1000 \text{ kg m}^{-3}) \\ &= 3 \times 10^{-29} \text{ m}^3 \\ &= (4/3) \pi (\text{Radius})^3 \\ \text{Hence, Radius} &\approx 2 \times 10^{-10} \text{ m} = 2 \text{ \AA} \end{aligned}$$

► **Example 12.3** What is the average distance between atoms (interatomic distance) in water? Use the data given in Examples 12.1 and 12.2.

**Answer:** A given mass of water in vapour state has  $1.67 \times 10^3$  times the volume of the same mass of water in liquid state (Ex. 12.1). This is also the increase in the amount of volume available for each molecule of water. When volume increases by  $10^3$  times the radius increases by  $V^{1/3}$  or 10 times, i.e.,  $10 \times 2 \text{ \AA} = 20 \text{ \AA}$ . So the average distance is  $2 \times 20 = 40 \text{ \AA}$ .

► **Example 12.4** A vessel contains two non-reactive gases : neon (monatomic) and oxygen (diatomic). The ratio of their partial pressures is 3:2. Estimate the ratio of (i)

number of molecules and (ii) mass density of neon and oxygen in the vessel. Atomic mass of Ne = 20.2 u, molecular mass of  $\text{O}_2 = 32.0 \text{ u}$ .

**Answer** Partial pressure of a gas in a mixture is the pressure it would have for the same volume and temperature if it alone occupied the vessel. (The total pressure of a mixture of non-reactive gases is the sum of partial pressures due to its constituent gases.) Each gas (assumed ideal) obeys the gas law. Since  $V$  and  $T$  are common to the two gases, we have  $P_1 V = \mu_1 RT$  and  $P_2 V = \mu_2 RT$ , i.e.  $(P_1/P_2) = (\mu_1/\mu_2)$ . Here 1 and 2 refer to neon and oxygen respectively. Since  $(P_1/P_2) = (3/2)$  (given),  $(\mu_1/\mu_2) = 3/2$ .

(i) By definition  $\mu_1 = (N_1/N_A)$  and  $\mu_2 = (N_2/N_A)$  where  $N_1$  and  $N_2$  are the number of molecules of 1 and 2, and  $N_A$  is the Avogadro's number.

Therefore,  $(N_1/N_2) = (\mu_1/\mu_2) = 3/2$ .

(ii) We can also write  $\mu_1 = (m_1/M_1)$  and  $\mu_2 = (m_2/M_2)$  where  $m_1$  and  $m_2$  are the masses of 1 and 2; and  $M_1$  and  $M_2$  are their molecular masses. (Both  $m_1$  and  $M_1$ ; as well as  $m_2$  and  $M_2$  should be expressed in the same units). If  $\rho_1$  and  $\rho_2$  are the mass densities of 1 and 2 respectively, we have

$$\begin{aligned} \frac{\rho_1}{\rho_2} &= \frac{m_1/V}{m_2/V} = \frac{m_1}{m_2} = \frac{\mu_1}{\mu_2} \times \left( \frac{M_1}{M_2} \right) \\ &= \frac{3}{2} \times \frac{20.2}{32.0} = 0.947 \end{aligned}$$

## 12.4 KINETIC THEORY OF AN IDEAL GAS

Kinetic theory of gases is based on the molecular picture of matter. A given amount of gas is a collection of a large number of molecules (typically of the order of Avogadro's number) that are in incessant random motion. At ordinary pressure and temperature, the average distance between molecules is a factor of 10 or more than the typical size of a molecule ( $2 \text{ \AA}$ ). Thus, interaction between molecules is negligible and we can assume that they move freely in straight lines according to Newton's first law. However, occasionally, they come close to each other, experience intermolecular forces and their velocities change. These interactions are called collisions. The molecules collide incessantly against each other or with the walls and change

their velocities. The collisions are considered to be elastic. We can derive an expression for the pressure of a gas based on the kinetic theory.

We begin with the idea that molecules of a gas are in incessant random motion, colliding against one another and with the walls of the container. All collisions between molecules among themselves or between molecules and the walls are elastic. This implies that total kinetic energy is conserved. The total momentum is conserved as usual.

### 12.4.1 Pressure of an Ideal Gas

Consider a gas enclosed in a cube of side  $l$ . Take the axes to be parallel to the sides of the cube, as shown in Fig. 12.4. A molecule with velocity  $(v_x, v_y, v_z)$  hits the planar wall parallel to  $yz$ -plane of area  $A (= l^2)$ . Since the collision is elastic, the molecule rebounds with the same velocity; its  $y$  and  $z$  components of velocity do not change in the collision but the  $x$ -component reverses sign. That is, the velocity after collision is  $(-v_x, v_y, v_z)$ . The change in momentum of the molecule is:  $-mv_x - (mv_x) = -2mv_x$ . By the principle of conservation of momentum, the momentum imparted to the wall in the collision  $= 2mv_x$ .

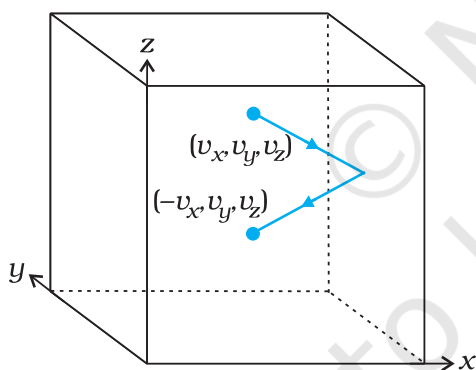

**Fig. 12.4** Elastic collision of a gas molecule with the wall of the container.

To calculate the force (and pressure) on the wall, we need to calculate momentum imparted to the wall per unit time. In a small time interval  $\Delta t$ , a molecule with  $x$ -component of velocity  $v_x$  will hit the wall if it is within the distance  $v_x \Delta t$  from the wall. That is, all molecules within the volume  $Av_x \Delta t$  only can hit the wall in time  $\Delta t$ . But, on the average, half of these are moving towards the wall and the other half away from

the wall. Thus, the number of molecules with velocity  $(v_x, v_y, v_z)$  hitting the wall in time  $\Delta t$  is  $\frac{1}{2}Av_x \Delta t n$ , where  $n$  is the number of molecules per unit volume. The total momentum transferred to the wall by these molecules in time  $\Delta t$  is:

$$Q = (2mv_x) (\frac{1}{2} n A v_x \Delta t) \quad (12.10)$$

The force on the wall is the rate of momentum transfer  $Q/\Delta t$  and pressure is force per unit area :

$$P = Q/(A \Delta t) = n m v_x^2 \quad (12.11)$$

Actually, all molecules in a gas do not have the same velocity; there is a distribution in velocities. The above equation, therefore, stands for pressure due to the group of molecules with speed  $v_x$  in the  $x$ -direction and  $n$  stands for the number density of that group of molecules. The total pressure is obtained by summing over the contribution due to all groups:

$$P = n m \overline{v_x^2} \quad (12.12)$$

where  $\overline{v_x^2}$  is the average of  $v_x^2$ . Now the gas is isotropic, i.e. there is no preferred direction of velocity of the molecules in the vessel. Therefore, by symmetry,

$$\begin{aligned} \overline{v_x^2} &= \overline{v_y^2} = \overline{v_z^2} \\ &= (1/3) [\overline{v_x^2} + \overline{v_y^2} + \overline{v_z^2}] = (1/3) \overline{v^2} \end{aligned} \quad (12.13)$$

where  $v$  is the speed and  $\overline{v^2}$  denotes the mean of the squared speed. Thus

$$P = (1/3) n m \overline{v^2} \quad (12.14)$$

Some remarks on this derivation. First, though we choose the container to be a cube, the shape of the vessel really is immaterial. For a vessel of arbitrary shape, we can always choose a small infinitesimal (planar) area and carry through the steps above. Notice that both  $A$  and  $\Delta t$  do not appear in the final result. By Pascal's law, given in Ch. 9, pressure in one portion of the gas in equilibrium is the same as anywhere else. Second, we have ignored any collisions in the derivation. Though this assumption is difficult to justify rigorously, we can qualitatively see that it will not lead to erroneous results. The number of molecules hitting the wall in time  $\Delta t$  was found to be  $\frac{1}{2} n A v_x \Delta t$ . Now the collisions are random and the gas is in a steady state. Thus, if a molecule with velocity  $(v_x, v_y, v_z)$  acquires a different velocity due to collision with some molecule, there will always be some other

molecule with a different initial velocity which after a collision acquires the velocity  $(v_x', v_y', v_z')$ . If this were not so, the distribution of velocities would not remain steady. In any case we are finding  $\overline{v_x^2}$ . Thus, on the whole, molecular collisions (if they are not too frequent and the time spent in a collision is negligible compared to time between collisions) will not affect the calculation above.

### 12.4.2 Kinetic Interpretation of Temperature

Equation (13.14) can be written as

$$PV = (1/3) nV m \overline{v^2} \quad (12.15a)$$

$$PV = (2/3) N \times \frac{1}{2} m \overline{v^2} \quad (12.15b)$$

where  $N (= nV)$  is the number of molecules in the sample.

The quantity in the bracket is the average translational kinetic energy of the molecules in the gas. Since the internal energy  $E$  of an ideal gas is purely kinetic\*,

$$E = N (1/2) m \overline{v^2} \quad (12.16)$$

Equation (12.15) then gives :

$$PV = (2/3) E \quad (12.17)$$

We are now ready for a kinetic interpretation of temperature. Combining Eq. (12.17) with the ideal gas Eq. (12.3), we get

$$E = (3/2) k_B NT \quad (12.18)$$

$$\text{or } E/N = \frac{1}{2} m \overline{v^2} = (3/2) k_B T \quad (12.19)$$

i.e., the average kinetic energy of a molecule is proportional to the absolute temperature of the gas; it is independent of pressure, volume or the nature of the ideal gas. This is a fundamental result relating temperature, a macroscopic measurable parameter of a gas (a thermodynamic variable as it is called) to a molecular quantity, namely the average kinetic energy of a molecule. The two domains are connected by the Boltzmann constant. We note in passing that Eq. (12.18) tells us that internal energy of an ideal gas depends only on temperature, not on pressure or volume. With this interpretation of temperature, kinetic theory of an ideal gas is completely consistent with the ideal gas equation and the various gas laws based on it.

For a mixture of non-reactive ideal gases, the total pressure gets contribution from each gas in the mixture. Equation (12.14) becomes

$$P = (1/3) [n_1 m_1 \overline{v_1^2} + n_2 m_2 \overline{v_2^2} + \dots] \quad (12.20)$$

In equilibrium, the average kinetic energy of the molecules of different gases will be equal. That is,

$$\frac{1}{2} m_1 \overline{v_1^2} = \frac{1}{2} m_2 \overline{v_2^2} = (3/2) k_B T$$

so that

$$P = (n_1 + n_2 + \dots) k_B T \quad (12.21)$$

which is Dalton's law of partial pressures.

From Eq. (12.19), we can get an idea of the typical speed of molecules in a gas. At a temperature  $T = 300$  K, the mean square speed of a molecule in nitrogen gas is :

$$m = \frac{M_{N_2}}{N_A} = \frac{28}{6.02 \times 10^{26}} = 4.65 \times 10^{-26} \text{ kg.}$$

$$\overline{v^2} = 3 k_B T / m = (516)^2 \text{ m}^2 \text{ s}^{-2}$$

The square root of  $\overline{v^2}$  is known as root mean square (rms) speed and is denoted by  $v_{\text{rms}}$ ,

(We can also write  $\overline{v^2}$  as  $\langle v^2 \rangle$ .)

$$v_{\text{rms}} = 516 \text{ m s}^{-1}$$

The speed is of the order of the speed of sound in air. It follows from Eq. (12.19) that at the same temperature, lighter molecules have greater rms speed.

**Example 12.5** A flask contains argon and chlorine in the ratio of 2:1 by mass. The temperature of the mixture is 27 °C. Obtain the ratio of (i) average kinetic energy per molecule, and (ii) root mean square speed  $v_{\text{rms}}$  of the molecules of the two gases. Atomic mass of argon = 39.9 u; Molecular mass of chlorine = 70.9 u.

**Answer** The important point to remember is that the average kinetic energy (per molecule) of any (ideal) gas (be it monatomic like argon, diatomic like chlorine or polyatomic) is always equal to  $(3/2) k_B T$ . It depends only on temperature, and is independent of the nature of the gas.

- (i) Since argon and chlorine both have the same temperature in the flask, the ratio of average kinetic energy (per molecule) of the two gases is 1:1.
- (ii) Now  $\frac{1}{2} m v_{\text{rms}}^2 = \text{average kinetic energy per molecule} = (3/2) k_B T$  where  $m$  is the mass

\*  $E$  denotes the translational part of the internal energy  $U$  that may include energies due to other degrees of freedom also. See section 12.5.

of a molecule of the gas. Therefore,

$$\frac{(\mathbf{v}_{rms})_{Ar}^2}{(\mathbf{v}_{rms})_{Cl}^2} = \frac{(m)_{Cl}}{(m)_{Ar}} = \frac{(M)_{Cl}}{(M)_{Ar}} = \frac{70.9}{39.9} = 1.77$$

where  $M$  denotes the molecular mass of the gas. (For argon, a molecule is just an atom of argon.) Taking square root of both sides,

$$\frac{(\mathbf{v}_{rms})_{Ar}}{(\mathbf{v}_{rms})_{Cl}} = 1.33$$

You should note that the composition of the mixture by mass is quite irrelevant to the above calculation. Any other proportion by mass of argon and chlorine would give the same answers to (i) and (ii), provided the temperature remains unaltered. ◀

**Example 12.6** Uranium has two isotopes of masses 235 and 238 units. If both are present in Uranium hexafluoride gas which would have the larger average speed? If atomic mass of fluorine is 19 units, estimate the percentage difference in speeds at any temperature.

**Answer** At a fixed temperature the average energy  $= \frac{1}{2} m \langle v^2 \rangle$  is constant. So smaller the mass of the molecule, faster will be the speed. The ratio of speeds is inversely proportional to the square root of the ratio of the masses. The masses are 349 and 352 units. So

$$v_{349} / v_{352} = (352 / 349)^{1/2} = 1.0044 .$$

$$\text{Hence difference } \frac{\Delta V}{V} = 0.44 \% .$$

[ $^{235}\text{U}$  is the isotope needed for nuclear fission. To separate it from the more abundant isotope  $^{238}\text{U}$ , the mixture is surrounded by a porous cylinder. The porous cylinder must be thick and narrow, so that the molecule wanders through individually, colliding with the walls of the long pore. The faster molecule will leak out more than the slower one and so there is more of the lighter molecule (enrichment) outside the porous cylinder (Fig. 12.5). The method is not very efficient and has to be repeated several times for sufficient enrichment.] ◀

When gases diffuse, their rate of diffusion is inversely proportional to square root of the masses (see Exercise 12.12). Can you guess the explanation from the above answer?

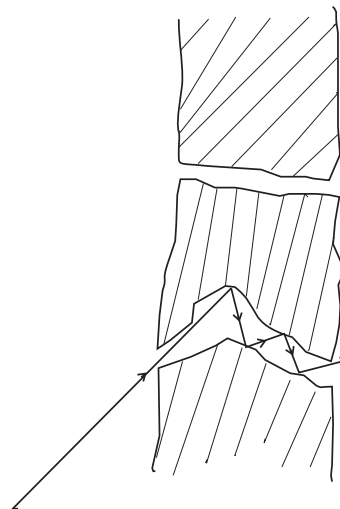

**Fig. 12.5** Molecules going through a porous wall.

**Example 12.7** (a) When a molecule (or an elastic ball) hits a (massive) wall, it rebounds with the same speed. When a ball hits a massive bat held firmly, the same thing happens. However, when the bat is moving towards the ball, the ball rebounds with a different speed. Does the ball move faster or slower? (Ch.5 will refresh your memory on elastic collisions.)

(b) When gas in a cylinder is compressed by pushing in a piston, its temperature rises. Guess at an explanation of this in terms of kinetic theory using (a) above.

(c) What happens when a compressed gas pushes a piston out and expands. What would you observe?

(d) Sachin Tendulkar used a heavy cricket bat while playing. Did it help him in anyway?

**Answer** (a) Let the speed of the ball be  $u$  relative to the wicket behind the bat. If the bat is moving towards the ball with a speed  $V$  relative to the wicket, then the relative speed of the ball to bat is  $V + u$  towards the bat. When the ball rebounds (after hitting the massive bat) its speed, relative to bat, is  $V + u$  moving away from the bat. So relative to the wicket the speed of the rebounding ball is  $V + (V + u) = 2V + u$ , moving away from the wicket. So the ball speeds up after the collision with the bat. The rebound speed will be less than  $u$  if the bat is not massive. For a molecule this would imply an increase in temperature.

You should be able to answer (b) (c) and (d) based on the answer to (a).

(Hint: Note the correspondence, piston  $\rightarrow$  bat, cylinder  $\rightarrow$  wicket, molecule  $\rightarrow$  ball.)  $\blacktriangleleft$

## 12.5 LAW OF EQUIPARTITION OF ENERGY

The kinetic energy of a single molecule is

$$\epsilon_t = \frac{1}{2}mv_x^2 + \frac{1}{2}mv_y^2 + \frac{1}{2}mv_z^2 \quad (12.22)$$

For a gas in thermal equilibrium at temperature  $T$  the average value of energy denoted by  $\langle \epsilon_t \rangle$  is

$$\langle \epsilon_t \rangle = \left\langle \frac{1}{2}mv_x^2 \right\rangle + \left\langle \frac{1}{2}mv_y^2 \right\rangle + \left\langle \frac{1}{2}mv_z^2 \right\rangle = \frac{3}{2}k_B T \quad (12.23)$$

Since there is no preferred direction, Eq. (12.23) implies

$$\left\langle \frac{1}{2}mv_x^2 \right\rangle = \frac{1}{2}k_B T, \quad \left\langle \frac{1}{2}mv_y^2 \right\rangle = \frac{1}{2}k_B T, \\ \left\langle \frac{1}{2}mv_z^2 \right\rangle = \frac{1}{2}k_B T \quad (12.24)$$

A molecule free to move in space needs three coordinates to specify its location. If it is constrained to move in a plane it needs two; and if constrained to move along a line, it needs just one coordinate to locate it. This can also be expressed in another way. We say that it has one degree of freedom for motion in a line, two for motion in a plane and three for motion in space. Motion of a body as a whole from one point to another is called translation. Thus, a molecule free to move in space has three translational degrees of freedom. Each translational degree of freedom contributes a term that contains square of some variable of motion, e.g.,  $\frac{1}{2}mv_x^2$  and similar terms in  $v_y$  and  $v_z$ . In, Eq. (12.24) we see that in thermal equilibrium, the average of each such term is  $\frac{1}{2}k_B T$ .

Molecules of a monatomic gas like argon have only translational degrees of freedom. But what about a diatomic gas such as  $O_2$  or  $N_2$ ? A molecule of  $O_2$  has three translational degrees of freedom. But in addition it can also rotate about its centre of mass. Figure 12.6 shows the two independent axes of rotation 1 and 2, normal

to the axis joining the two oxygen atoms about which the molecule can rotate\*. The molecule thus has two rotational degrees of freedom, each of which contributes a term to the total energy consisting of translational energy  $\epsilon_t$  and rotational energy  $\epsilon_r$ .

$$\epsilon_t + \epsilon_r = \frac{1}{2}mv_x^2 + \frac{1}{2}mv_y^2 + \frac{1}{2}mv_z^2 + \frac{1}{2}I_1\omega_1^2 + \frac{1}{2}I_2\omega_2^2 \quad (12.25)$$

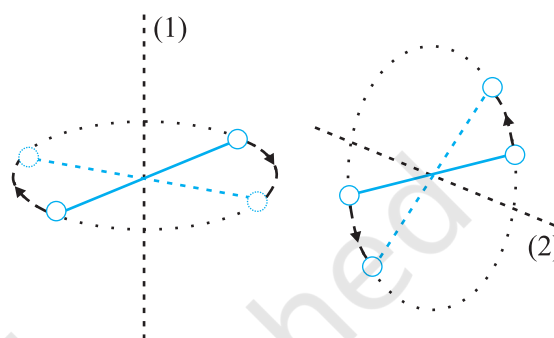

**Fig. 12.6** The two independent axes of rotation of a diatomic molecule

where  $\omega_1$  and  $\omega_2$  are the angular speeds about the axes 1 and 2 and  $I_1, I_2$  are the corresponding moments of inertia. Note that each rotational degree of freedom contributes a term to the energy that contains square of a rotational variable of motion.

We have assumed above that the  $O_2$  molecule is a 'rigid rotator', i.e., the molecule does not vibrate. This assumption, though found to be true (at moderate temperatures) for  $O_2$ , is not always valid. Molecules, like CO, even at moderate temperatures have a mode of vibration, i.e., its atoms oscillate along the interatomic axis like a one-dimensional oscillator, and contribute a vibrational energy term  $\epsilon_v$  to the total energy:

$$\epsilon_v = \frac{1}{2}m \left( \frac{dy}{dt} \right)^2 + \frac{1}{2}ky^2 \\ \epsilon = \epsilon_t + \epsilon_r + \epsilon_v \quad (12.26)$$

where  $k$  is the force constant of the oscillator and  $y$  the vibrational co-ordinate.

Once again the vibrational energy terms in Eq. (12.26) contain squared terms of vibrational variables of motion  $y$  and  $dy/dt$ .

\* Rotation along the line joining the atoms has very small moment of inertia and does not come into play for quantum mechanical reasons. See end of section 12.6.

At this point, notice an important feature in Eq.(12.26). While each translational and rotational degree of freedom has contributed only one 'squared term' in Eq.(12.26), one vibrational mode contributes two 'squared terms' : kinetic and potential energies.

Each quadratic term occurring in the expression for energy is a mode of absorption of energy by the molecule. We have seen that in thermal equilibrium at absolute temperature  $T$ , for each translational mode of motion, the average energy is  $\frac{1}{2} k_B T$ . The most elegant principle of classical statistical mechanics (first proved by Maxwell) states that this is so for each mode of energy: translational, rotational and vibrational. That is, in equilibrium, the total energy is equally distributed in all possible energy modes, with each mode having an average energy equal to  $\frac{1}{2} k_B T$ . This is known as the **law of equipartition of energy**. Accordingly, each translational and rotational degree of freedom of a molecule contributes  $\frac{1}{2} k_B T$  to the energy, while each vibrational frequency contributes  $2 \times \frac{1}{2} k_B T = k_B T$ , since a vibrational mode has both kinetic and potential energy modes.

The proof of the law of equipartition of energy is beyond the scope of this book. Here, we shall apply the law to predict the specific heats of gases theoretically. Later, we shall also discuss briefly, the application to specific heat of solids.

## 12.6 SPECIFIC HEAT CAPACITY

### 12.6.1 Monatomic Gases

The molecule of a monatomic gas has only three translational degrees of freedom. Thus, the average energy of a molecule at temperature  $T$  is  $(3/2)k_B T$ . The total internal energy of a mole of such a gas is

$$U = \frac{3}{2} k_B T \times N_A = \frac{3}{2} RT \quad (12.27)$$

The molar specific heat at constant volume,  $C_v$ , is

$$C_v \text{ (monatomic gas)} = \frac{dU}{dT} = \frac{3}{2} RT \quad (12.28)$$

For an ideal gas,

$$C_p - C_v = R \quad (12.29)$$

where  $C_p$  is the molar specific heat at constant pressure. Thus,

$$C_p = \frac{5}{2} R \quad (12.30)$$

The ratio of specific heats  $\gamma = \frac{C_p}{C_v} = \frac{5}{3}$  (12.31)

### 12.6.2 Diatomic Gases

As explained earlier, a diatomic molecule treated as a rigid rotator, like a dumbbell, has 5 degrees of freedom: 3 translational and 2 rotational. Using the law of equipartition of energy, the total internal energy of a mole of such a gas is

$$U = \frac{5}{2} k_B T \times N_A = \frac{5}{2} RT \quad (12.32)$$

The molar specific heats are then given by

$$C_v \text{ (rigid diatomic)} = \frac{5}{2} R, C_p = \frac{7}{2} R \quad (12.33)$$

$$\gamma \text{ (rigid diatomic)} = \frac{7}{5} \quad (12.34)$$

If the diatomic molecule is not rigid but has in addition a vibrational mode

$$U = \left( \frac{5}{2} k_B T + k_B T \right) N_A = \frac{7}{2} RT$$

$$C_v = \frac{7}{2} R, C_p = \frac{9}{2} R, \gamma = \frac{9}{7} R \quad (12.35)$$

### 12.6.3 Polyatomic Gases

In general a polyatomic molecule has 3 translational, 3 rotational degrees of freedom and a certain number ( $f$ ) of vibrational modes. According to the law of equipartition of energy, it is easily seen that one mole of such a gas has

$$U = \left( \frac{3}{2} k_B T + \frac{3}{2} k_B T + f k_B T \right) N_A$$

i.e.,  $C_v = (3 + f) R, C_p = (4 + f) R,$

$$\gamma = \frac{(4 + f)}{(3 + f)} \quad (12.36)$$

Note that  $C_p - C_v = R$  is true for any ideal gas, whether mono, di or polyatomic.

Table 12.1 summarises the theoretical predictions for specific heats of gases ignoring any vibrational modes of motion. The values are

in good agreement with experimental values of specific heats of several gases given in Table 12.2. Of course, there are discrepancies between predicted and actual values of specific heats of several other gases (not shown in the table), such as  $\text{Cl}_2$ ,  $\text{C}_2\text{H}_6$  and many other polyatomic gases. Usually, the experimental values for specific heats of these gases are greater than the predicted values as given in Table 12.1 suggesting that the agreement can be improved by including vibrational modes of motion in the calculation. The law of equipartition of energy is, thus, well verified experimentally at ordinary temperatures.

**Table 12.1 Predicted values of specific heat capacities of gases (ignoring vibrational modes)**

Nature of Gas	$C_v$ ( $\text{J mol}^{-1} \text{K}^{-1}$ )	$C_p$ ( $\text{J mol}^{-1} \text{K}^{-1}$ )	$C_p - C_v$ ( $\text{J mol}^{-1} \text{K}^{-1}$ )	$\gamma$
Monatomic	12.5	20.8	8.31	1.67
Diatomic	20.8	29.1	8.31	1.40
Triatomic	24.93	33.24	8.31	1.33

**Table 12.2 Measured values of specific heat capacities of some gases**

Nature of gas	Gas	$C_v$ ( $\text{J mol}^{-1} \text{K}^{-1}$ )	$C_p$ ( $\text{J mol}^{-1} \text{K}^{-1}$ )	$C_p - C_v$ ( $\text{J mol}^{-1} \text{K}^{-1}$ )	$\gamma$
Monatomic	He	12.5	20.8	8.30	1.66
Monatomic	Ne	12.7	20.8	8.12	1.64
Monatomic	Ar	12.5	20.8	8.30	1.67
Diatomic	$\text{H}_2$	20.4	28.8	8.45	1.41
Diatomic	$\text{O}_2$	21.0	29.3	8.32	1.40
Diatomic	$\text{N}_2$	20.8	29.1	8.32	1.40
Triatomic	$\text{H}_2\text{O}$	27.0	35.4	8.35	1.31
Polyatomic	$\text{CH}_4$	27.1	35.4	8.36	1.31

**Example 12.8** A cylinder of fixed capacity 44.8 litres contains helium gas at standard temperature and pressure. What is the amount of heat needed to raise the temperature of the gas in the cylinder by  $15.0^\circ\text{C}$ ? ( $R = 8.31 \text{ J mol}^{-1} \text{K}^{-1}$ ).

**Answer** Using the gas law  $PV = \mu RT$ , you can easily show that 1 mol of any (ideal) gas at standard temperature (273 K) and pressure ( $1 \text{ atm} = 1.01 \times 10^5 \text{ Pa}$ ) occupies a volume of 22.4 litres. This universal volume is called molar volume. Thus the cylinder in this example contains 2 mol of helium. Further, since helium is monatomic, its predicted (and observed) molar specific heat at constant volume,  $C_v = (3/2) R$ , and molar specific heat at constant pressure,  $C_p = (3/2) R + R = (5/2) R$ . Since the volume of the cylinder is fixed, the heat required is determined by  $C_v$ . Therefore,

$$\begin{aligned} \text{Heat required} &= \text{no. of moles} \times \text{molar specific heat rise in temperature} \\ &= 2 \times 1.5 R \times 15.0 = 45 R \\ &= 45 \times 8.31 = 374 \text{ J.} \end{aligned}$$

#### 12.6.4 Specific Heat Capacity of Solids

We can use the law of equipartition of energy to determine specific heats of solids. Consider a solid of  $N$  atoms, each vibrating about its mean position. An oscillation in one dimension has average energy of  $2 \times \frac{1}{2} k_B T = k_B T$ . In three dimensions, the average energy is  $3 k_B T$ . For a mole of solid,  $N = N_A$ , and the total energy is

$$U = 3 k_B T \times N_A = 3 RT$$

Now at constant pressure  $\Delta Q = \Delta U + P\Delta V = \Delta U$ , since for a solid  $\Delta V$  is negligible. Hence,

$$C = \frac{\Delta Q}{\Delta T} = \frac{\Delta U}{\Delta T} = 3R \quad (12.37)$$

**Table 12.3 Specific Heat Capacity of some solids at room temperature and atmospheric pressure**

Substance	Specific heat ( $\text{J kg}^{-1} \text{K}^{-1}$ )	Molar specific heat ( $\text{J mol}^{-1} \text{K}^{-1}$ )
Aluminium	900.0	24.4
Carbon	506.5	6.1
Copper	386.4	24.5
Lead	127.7	26.5
Silver	236.1	25.5
Tungsten	134.4	24.9

As Table 12.3 shows the prediction generally agrees with experimental values at ordinary temperature (Carbon is an exception).

#### 12.7 MEAN FREE PATH

Molecules in a gas have rather large speeds of the order of the speed of sound. Yet a gas leaking

from a cylinder in a kitchen takes considerable time to diffuse to the other corners of the room. The top of a cloud of smoke holds together for hours. This happens because molecules in a gas have a finite though small size, so they are bound to undergo collisions. As a result, they cannot move straight unhindered; their paths keep getting incessantly deflected.

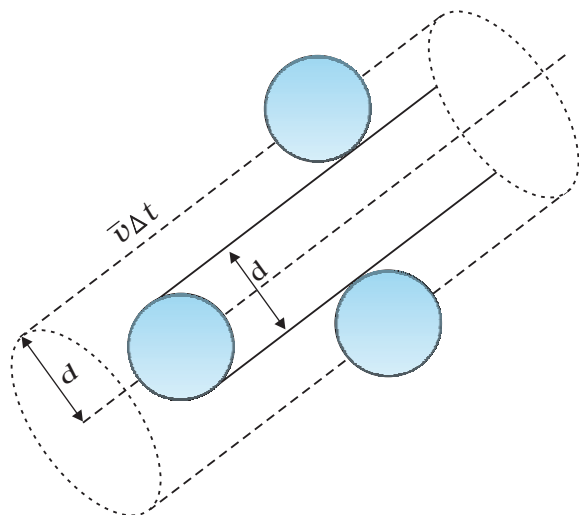

**Fig. 12.7** The volume swept by a molecule in time  $\Delta t$  in which any molecule will collide with it.

Suppose the molecules of a gas are spheres of diameter  $d$ . Focus on a single molecule with the average speed  $\langle v \rangle$ . It will suffer collision with any molecule that comes within a distance  $d$  between the centres. In time  $\Delta t$ , it sweeps a volume  $\pi d^2 \langle v \rangle \Delta t$  wherein any other molecule will collide with it (see Fig. 12.7). If  $n$  is the number of molecules per unit volume, the molecule suffers  $n\pi d^2 \langle v \rangle \Delta t$  collisions in time  $\Delta t$ . Thus the rate of collisions is  $n\pi d^2 \langle v \rangle$  or the time between two successive collisions is on the average,

$$\tau = 1/(n\pi \langle v \rangle d^2) \quad (12.38)$$

The average distance between two successive collisions, called the mean free path  $l$ , is :

$$l = \langle v \rangle \tau = 1/(n\pi d^2) \quad (12.39)$$

In this derivation, we imagined the other molecules to be at rest. But actually all molecules

are moving and the collision rate is determined by the average relative velocity of the molecules. Thus we need to replace  $\langle v \rangle$  by  $\langle v_r \rangle$  in Eq. (12.38). A more exact treatment gives

$$l = 1/(\sqrt{2} n\pi d^2) \quad (12.40)$$

Let us estimate  $l$  and  $\tau$  for air molecules with average speeds  $\langle v \rangle = (485 \text{ m/s})$ . At STP

$$n = \frac{(0.02 \times 10^{23})}{(22.4 \times 10^{-3})}$$

$$= 2.7 \times 10^{25} \text{ m}^{-3}$$

Taking,  $d = 2 \times 10^{-10} \text{ m}$ ,

$$\tau = 6.1 \times 10^{-10} \text{ s}$$

$$\text{and } l = 2.9 \times 10^{-7} \text{ m} \approx 1500 d \quad (12.41)$$

As expected, the mean free path given by Eq. (12.40) depends inversely on the number density and the size of the molecules. In a highly evacuated tube  $n$  is rather small and the mean free path can be as large as the length of the tube.

**Example 12.9** Estimate the mean free path for a water molecule in water vapour at 373 K. Use information from Exercises 12.1 and Eq. (12.41) above.

**Answer** The  $d$  for water vapour is same as that of air. The number density is inversely proportional to absolute temperature.

$$\text{So } n = 2.7 \times 10^{25} \times \frac{273}{373} = 2 \times 10^{25} \text{ m}^{-3}$$

$$\text{Hence, mean free path } l = 4 \times 10^{-7} \text{ m} \quad \blacktriangleleft$$

Note that the mean free path is 100 times the interatomic distance  $\sim 40 \text{ \AA} = 4 \times 10^{-9} \text{ m}$  calculated earlier. It is this large value of mean free path that leads to the typical gaseous behaviour. Gases can not be confined without a container.

Using, the kinetic theory of gases, the bulk measurable properties like viscosity, heat conductivity and diffusion can be related to the microscopic parameters like molecular size. It is through such relations that the molecular sizes were first estimated.



## SUMMARY

1. The ideal gas equation connecting pressure ( $P$ ), volume ( $V$ ) and absolute temperature ( $T$ ) is

$$PV = \mu RT = k_B NT$$

where  $\mu$  is the number of moles and  $N$  is the number of molecules.  $R$  and  $k_B$  are universal constants.

$$R = 8.314 \text{ J mol}^{-1} \text{ K}^{-1}, \quad k_B = \frac{R}{N_A} = 1.38 \times 10^{-23} \text{ J K}^{-1}$$

Real gases satisfy the ideal gas equation only approximately, more so at low pressures and high temperatures.

2. Kinetic theory of an ideal gas gives the relation

$$P = \frac{1}{3} n m \overline{v^2}$$

where  $n$  is number density of molecules,  $m$  the mass of the molecule and  $\overline{v^2}$  is the mean of squared speed. Combined with the ideal gas equation it yields a kinetic interpretation of temperature.

$$\frac{1}{2} m \overline{v^2} = \frac{3}{2} k_B T, \quad v_{rms} = (\overline{v^2})^{1/2} = \sqrt{\frac{3k_B T}{m}}$$

This tells us that the temperature of a gas is a measure of the average kinetic energy of a molecule, *independent of the nature of the gas or molecule*. In a mixture of gases at a fixed temperature the heavier molecule has the lower average speed.

3. The translational kinetic energy

$$E = \frac{3}{2} k_B NT.$$

This leads to a relation

$$PV = \frac{2}{3} E$$

4. The law of equipartition of energy states that if a system is in equilibrium at absolute temperature  $T$ , the total energy is distributed equally in different energy modes of absorption, the energy in each mode being equal to  $\frac{1}{2} k_B T$ . Each translational and rotational degree of freedom corresponds to one energy mode of absorption and has energy  $\frac{1}{2} k_B T$ . Each vibrational frequency has two modes of energy (kinetic and potential) with corresponding energy equal to

$$2 \times \frac{1}{2} k_B T = k_B T.$$

5. Using the law of equipartition of energy, the molar specific heats of gases can be determined and the values are in agreement with the experimental values of specific heats of several gases. The agreement can be improved by including vibrational modes of motion.
6. The mean free path  $l$  is the average distance covered by a molecule between two successive collisions :

$$l = \frac{1}{\sqrt{2} n \pi d^2}$$

where  $n$  is the number density and  $d$  the diameter of the molecule.

**POINTS TO PONDER**

1. Pressure of a fluid is not only exerted on the wall. Pressure exists everywhere in a fluid. Any layer of gas inside the volume of a container is in equilibrium because the pressure is the same on both sides of the layer.
2. We should not have an exaggerated idea of the intermolecular distance in a gas. At ordinary pressures and temperatures, this is only 10 times or so the interatomic distance in solids and liquids. What is different is the mean free path which in a gas is 100 times the interatomic distance and 1000 times the size of the molecule.
3. The law of equipartition of energy is stated thus: the energy for each degree of freedom in thermal equilibrium is  $\frac{1}{2} k_B T$ . Each quadratic term in the total energy expression of a molecule is to be counted as a degree of freedom. Thus, each vibrational mode gives 2 (not 1) degrees of freedom (kinetic and potential energy modes), corresponding to the energy  $2 \times \frac{1}{2} k_B T = k_B T$ .
4. Molecules of air in a room do not all fall and settle on the ground (due to gravity) because of their high speeds and incessant collisions. In equilibrium, there is a very slight increase in density at lower heights (like in the atmosphere). The effect is small since the potential energy ( $mgh$ ) for ordinary heights is much less than the average kinetic energy  $\frac{1}{2} mv^2$  of the molecules.
5.  $\langle v^2 \rangle$  is not always equal to  $(\langle v \rangle)^2$ . The average of a squared quantity is not necessarily the square of the average. Can you find examples for this statement.

**EXERCISES**

- 12.1** Estimate the fraction of molecular volume to the actual volume occupied by oxygen gas at STP. Take the diameter of an oxygen molecule to be 3 Å.
- 12.2** Molar volume is the volume occupied by 1 mol of any (ideal) gas at standard temperature and pressure (STP : 1 atmospheric pressure, 0 °C). Show that it is 22.4 litres.
- 12.3** Figure 12.8 shows plot of  $PV/T$  versus  $P$  for  $1.00 \times 10^{-3}$  kg of oxygen gas at two different temperatures.

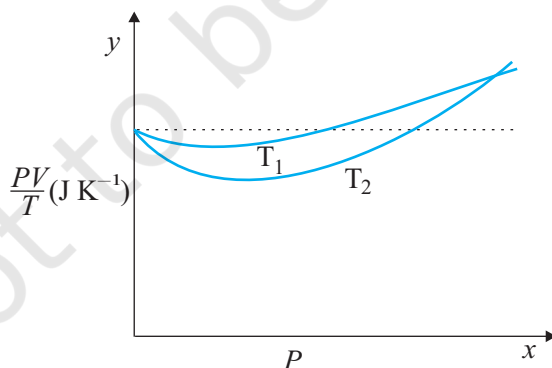
**Fig. 12.8**

- (a) What does the dotted plot signify?
- (b) Which is true:  $T_1 > T_2$  or  $T_1 < T_2$ ?
- (c) What is the value of  $PV/T$  where the curves meet on the  $y$ -axis?

(d) If we obtained similar plots for  $1.00 \times 10^{-3}$  kg of hydrogen, would we get the same value of  $PV/T$  at the point where the curves meet on the  $y$ -axis? If not, what mass of hydrogen yields the same value of  $PV/T$  (for low pressure high temperature region of the plot) ? (Molecular mass of  $H_2 = 2.02$  u, of  $O_2 = 32.0$  u,  $R = 8.31$  J mol $^{-1}$  K $^{-1}$ .)

- 12.4** An oxygen cylinder of volume 30 litre has an initial gauge pressure of 15 atm and a temperature of 27 °C. After some oxygen is withdrawn from the cylinder, the gauge pressure drops to 11 atm and its temperature drops to 17 °C. Estimate the mass of oxygen taken out of the cylinder ( $R = 8.31$  J mol $^{-1}$  K $^{-1}$ , molecular mass of  $O_2 = 32$  u).
- 12.5** An air bubble of volume 1.0 cm $^3$  rises from the bottom of a lake 40 m deep at a temperature of 12 °C. To what volume does it grow when it reaches the surface, which is at a temperature of 35 °C ?
- 12.6** Estimate the total number of air molecules (inclusive of oxygen, nitrogen, water vapour and other constituents) in a room of capacity 25.0 m $^3$  at a temperature of 27 °C and 1 atm pressure.
- 12.7** Estimate the average thermal energy of a helium atom at (i) room temperature (27 °C), (ii) the temperature on the surface of the Sun (6000 K), (iii) the temperature of 10 million kelvin (the typical core temperature in the case of a star).
- 12.8** Three vessels of equal capacity have gases at the same temperature and pressure. The first vessel contains neon (monatomic), the second contains chlorine (diatomic), and the third contains uranium hexafluoride (polyatomic). Do the vessels contain equal number of respective molecules ? Is the root mean square speed of molecules the same in the three cases? If not, in which case is  $v_{\text{rms}}$  the largest ?
- 12.9** At what temperature is the root mean square speed of an atom in an argon gas cylinder equal to the rms speed of a helium gas atom at  $-20$  °C ? (atomic mass of Ar = 39.9 u, of He = 4.0 u).
- 12.10** Estimate the mean free path and collision frequency of a nitrogen molecule in a cylinder containing nitrogen at 2.0 atm and temperature 17 °C. Take the radius of a nitrogen molecule to be roughly 1.0 Å. Compare the collision time with the time the molecule moves freely between two successive collisions (Molecular mass of  $N_2 = 28.0$  u).



## OSCILLATIONS

- 13.1** Introduction
- 13.2** Periodic and oscillatory motions
- 13.3** Simple harmonic motion
- 13.4** Simple harmonic motion and uniform circular motion
- 13.5** Velocity and acceleration in simple harmonic motion
- 13.6** Force law for simple harmonic motion
- 13.7** Energy in simple harmonic motion
- 13.8** The simple pendulum
- Summary
- Points to ponder
- Exercises

### 13.1 INTRODUCTION

In our daily life we come across various kinds of motions. You have already learnt about some of them, e.g., rectilinear motion and motion of a projectile. Both these motions are non-repetitive. We have also learnt about uniform circular motion and orbital motion of planets in the solar system. In these cases, the motion is repeated after a certain interval of time, that is, it is periodic. In your childhood, you must have enjoyed rocking in a cradle or swinging on a swing. Both these motions are repetitive in nature but different from the periodic motion of a planet. Here, the object moves to and fro about a mean position. The pendulum of a wall clock executes a similar motion. Examples of such periodic to and fro motion abound: a boat tossing up and down in a river, the piston in a steam engine going back and forth, etc. Such a motion is termed as oscillatory motion. In this chapter we study this motion.

The study of oscillatory motion is basic to physics; its concepts are required for the understanding of many physical phenomena. In musical instruments, like the sitar, the guitar or the violin, we come across vibrating strings that produce pleasing sounds. The membranes in drums and diaphragms in telephone and speaker systems vibrate to and fro about their mean positions. The vibrations of air molecules make the propagation of sound possible. In a solid, the atoms vibrate about their equilibrium positions, the average energy of vibrations being proportional to temperature. AC power supply give voltage that oscillates alternately going positive and negative about the mean value (zero).

The description of a periodic motion, in general, and oscillatory motion, in particular, requires some fundamental concepts, like period, frequency, displacement, amplitude and phase. These concepts are developed in the next section.

### 13.2 PERIODIC AND OSCILLATORY MOTIONS

Fig. 13.1 shows some periodic motions. Suppose an insect climbs up a ramp and falls down, it comes back to the initial point and repeats the process identically. If you draw a graph of its height above the ground versus time, it would look something like Fig. 13.1 (a). If a child climbs up a step, comes down, and repeats the process identically, its height above the ground would look like that in Fig. 13.1 (b). When you play the game of bouncing a ball off the ground, between your palm and the ground, its height versus time graph would look like the one in Fig. 13.1 (c). Note that both the curved parts in Fig. 13.1 (c) are sections of a parabola given by the Newton's equation of motion (see section 2.6),

$$h = ut + \frac{1}{2}gt^2 \text{ for downward motion, and}$$

$$h = ut - \frac{1}{2}gt^2 \text{ for upward motion,}$$

with different values of  $u$  in each case. These are examples of periodic motion. Thus, a motion that repeats itself at regular intervals of time is called **periodic motion**.

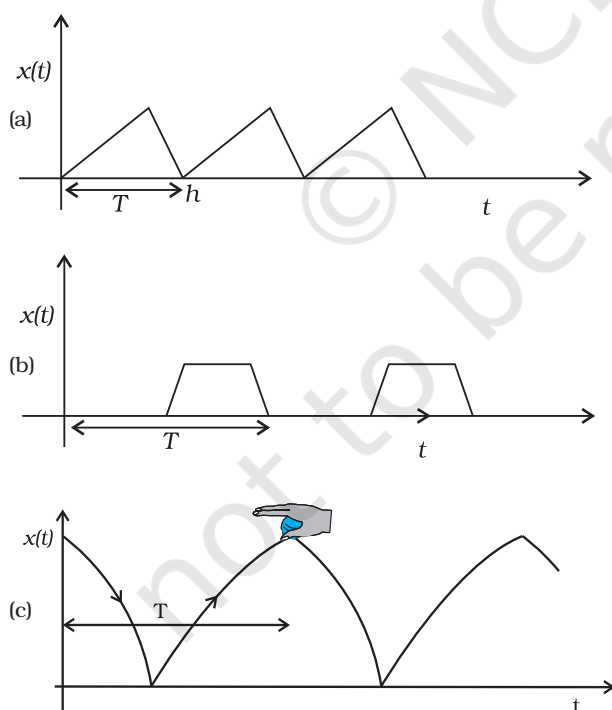

**Fig. 13.1** Examples of periodic motion. The period  $T$  is shown in each case.

Very often, the body undergoing periodic motion has an equilibrium position somewhere inside its path. When the body is at this position no net external force acts on it. Therefore, if it is left there at rest, it remains there forever. If the body is given a small displacement from the position, a force comes into play which tries to bring the body back to the equilibrium point, giving rise to **oscillations** or **vibrations**. For example, a ball placed in a bowl will be in equilibrium at the bottom. If displaced a little from the point, it will perform oscillations in the bowl. Every oscillatory motion is periodic, but every periodic motion need not be oscillatory. Circular motion is a periodic motion, but it is not oscillatory.

There is no significant difference between oscillations and vibrations. It seems that when the frequency is small, we call it oscillation (like, the oscillation of a branch of a tree), while when the frequency is high, we call it vibration (like, the vibration of a string of a musical instrument).

Simple harmonic motion is the simplest form of oscillatory motion. This motion arises when the force on the oscillating body is directly proportional to its displacement from the mean position, which is also the equilibrium position. Further, at any point in its oscillation, this force is directed towards the mean position.

In practice, oscillating bodies eventually come to rest at their equilibrium positions because of the damping due to friction and other dissipative causes. However, they can be forced to remain oscillating by means of some external periodic agency. We discuss the phenomena of damped and forced oscillations later in the chapter.

Any material medium can be pictured as a collection of a large number of coupled oscillators. The collective oscillations of the constituents of a medium manifest themselves as waves. Examples of waves include water waves, seismic waves, electromagnetic waves. We shall study the wave phenomenon in the next chapter.

#### 13.2.1 Period and frequency

We have seen that any motion that repeats itself at regular intervals of time is called **periodic motion**. The smallest interval of time after which the motion is repeated is called its **period**. Let us denote the period by the symbol  $T$ . Its SI unit is second. For periodic motions,

which are either too fast or too slow on the scale of seconds, other convenient units of time are used. The period of vibrations of a quartz crystal is expressed in units of microseconds ( $10^{-6}$  s) abbreviated as  $\mu\text{s}$ . On the other hand, the orbital period of the planet Mercury is 88 earth days. The Halley's comet appears after every 76 years.

The reciprocal of  $T$  gives the number of repetitions that occur per unit time. This quantity is called the **frequency of the periodic motion**. It is represented by the symbol  $\nu$ . The relation between  $\nu$  and  $T$  is

$$\nu = 1/T \tag{13.1}$$

The unit of  $\nu$  is thus  $\text{s}^{-1}$ . After the discoverer of radio waves, Heinrich Rudolph Hertz (1857–1894), a special name has been given to the unit of frequency. It is called hertz (abbreviated as Hz). Thus,

$$1 \text{ hertz} = 1 \text{ Hz} = 1 \text{ oscillation per second} = 1 \text{ s}^{-1} \tag{13.2}$$

Note, that the frequency,  $\nu$ , is not necessarily an integer.

► **Example 13.1** On an average, a human heart is found to beat 75 times in a minute. Calculate its frequency and period.

**Answer** The beat frequency of heart =  $75/(1 \text{ min})$   
 $= 75/(60 \text{ s})$   
 $= 1.25 \text{ s}^{-1}$   
 $= 1.25 \text{ Hz}$   
 The time period  $T = 1/(1.25 \text{ s}^{-1})$   
 $= 0.8 \text{ s}$

### 13.2.2 Displacement

In section 3.2, we defined displacement of a particle as the change in its position vector. In this chapter, we use the term displacement in a more general sense. It refers to change with time of any physical property under consideration. For example, in case of rectilinear motion of a steel ball on a surface, the distance from the starting point as a function of time is its position displacement. The choice of origin is a matter of convenience. Consider a block attached to a spring, the other end of the spring is fixed to a rigid wall [see Fig. 13.2(a)]. Generally, it is convenient to measure displacement of the body from its equilibrium position. For an oscillating simple pendulum, the angle from the vertical as a function of time may be regarded

as a displacement variable [see Fig. 13.2(b)]. The term displacement is not always to be referred

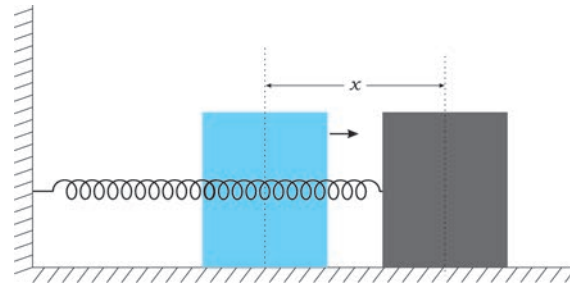

**Fig. 13.2(a)** A block attached to a spring, the other end of which is fixed to a rigid wall. The block moves on a frictionless surface. The motion of the block can be described in terms of its distance or displacement  $x$  from the equilibrium position.

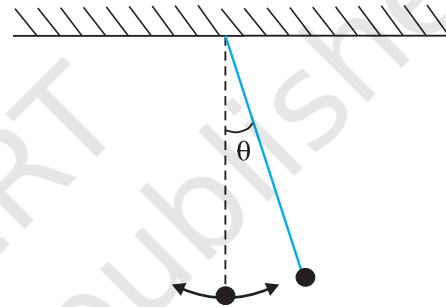

**Fig. 13.2(b)** An oscillating simple pendulum; its motion can be described in terms of angular displacement  $\theta$  from the vertical.

in the context of position only. There can be many other kinds of displacement variables. The voltage across a capacitor, changing with time in an AC circuit, is also a displacement variable. In the same way, pressure variations in time in the propagation of sound wave, the changing electric and magnetic fields in a light wave are examples of displacement in different contexts. The displacement variable may take both positive and negative values. In experiments on oscillations, the displacement is measured for different times.

The displacement can be represented by a mathematical function of time. In case of periodic motion, this function is periodic in time. One of the simplest periodic functions is given by

$$f(t) = A \cos \omega t \tag{13.3a}$$

If the argument of this function,  $\omega t$ , is increased by an integral multiple of  $2\pi$  radians, the value of the function remains the same. The

function  $f(t)$  is then periodic and its period,  $T$ , is given by

$$T = \frac{2\pi}{\omega} \quad (13.3b)$$

Thus, the function  $f(t)$  is periodic with period  $T$ ,

$$f(t) = f(t+T)$$

The same result is obviously correct if we consider a sine function,  $f(t) = A \sin \omega t$ . Further, a linear combination of sine and cosine functions like,

$$f(t) = A \sin \omega t + B \cos \omega t \quad (13.3c)$$

is also a periodic function with the same period  $T$ . Taking,

$$A = D \cos \phi \text{ and } B = D \sin \phi$$

Eq. (13.3c) can be written as,

$$f(t) = D \sin (\omega t + \phi), \quad (13.3d)$$

Here  $D$  and  $\phi$  are constant given by

$$D = \sqrt{A^2 + B^2} \text{ and } \phi = \tan^{-1} \left( \frac{B}{A} \right)$$

The great importance of periodic sine and cosine functions is due to a remarkable result proved by the French mathematician, Jean Baptiste Joseph Fourier (1768–1830): **Any periodic function can be expressed as a superposition of sine and cosine functions of different time periods with suitable coefficients.**

► **Example 13.2** Which of the following functions of time represent (a) periodic and (b) non-periodic motion? Give the period for each case of periodic motion [ $\omega$  is any positive constant].

- (i)  $\sin \omega t + \cos \omega t$
- (ii)  $\sin \omega t + \cos 2 \omega t + \sin 4 \omega t$
- (iii)  $e^{-\omega t}$
- (iv)  $\log (\omega t)$

### Answer

- (i)  $\sin \omega t + \cos \omega t$  is a periodic function, it can also be written as  $\sqrt{2} \sin (\omega t + \pi/4)$ .

$$\begin{aligned} \text{Now } \sqrt{2} \sin (\omega t + \pi/4) &= \sqrt{2} \sin (\omega t + \pi/4 + 2\pi) \\ &= \sqrt{2} \sin [\omega (t + 2\pi/\omega) + \pi/4] \end{aligned}$$

The periodic time of the function is  $2\pi/\omega$ .

- (ii) This is an example of a periodic motion. It can be noted that each term represents a periodic function with a different angular frequency. Since period is the least interval of time after which a function repeats its value,  $\sin \omega t$  has a period  $T_0 = 2\pi/\omega$ ;  $\cos 2 \omega t$  has a period  $\pi/\omega = T_0/2$ ; and  $\sin 4 \omega t$  has a period  $2\pi/4\omega = T_0/4$ . The period of the first term is a multiple of the periods of the last two terms. Therefore, the smallest interval of time after which the sum of the three terms repeats is  $T_0$ , and thus, the sum is a periodic function with a period  $2\pi/\omega$ .
- (iii) The function  $e^{-\omega t}$  is not periodic, it decreases monotonically with increasing time and tends to zero as  $t \rightarrow \infty$  and thus, never repeats its value.
- (iv) The function  $\log(\omega t)$  increases monotonically with time  $t$ . It, therefore, never repeats its value and is a non-periodic function. It may be noted that as  $t \rightarrow \infty$ ,  $\log(\omega t)$  diverges to  $\infty$ . It, therefore, cannot represent any kind of physical displacement. ◀

### 13.3 SIMPLE HARMONIC MOTION

Consider a particle oscillating back and forth about the origin of an  $x$ -axis between the limits  $+A$  and  $-A$  as shown in Fig. 13.3. This oscillatory motion is said to be simple harmonic if the displacement  $x$  of the particle from the origin varies with time as :

$$x(t) = A \cos (\omega t + \phi) \quad (13.4)$$

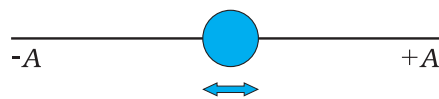

**Fig. 13.3** A particle vibrating back and forth about the origin of  $x$ -axis, between the limits  $+A$  and  $-A$ .

where  $A$ ,  $\omega$  and  $\phi$  are constants.

Thus, simple harmonic motion (SHM) is not any periodic motion but one in which displacement is a sinusoidal function of time. Fig. 13.4 shows the positions of a particle executing SHM at discrete value of time, each interval of time being  $T/4$ , where  $T$  is the period of motion. Fig. 13.5 plots the graph of  $x$  versus  $t$ , which gives the values of displacement as a continuous function of time. The quantities  $A$ ,

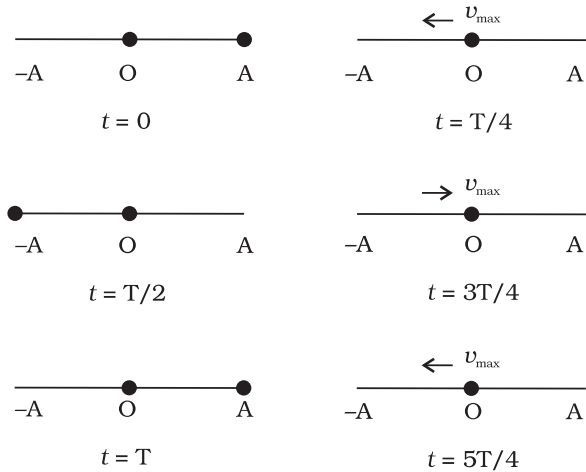

**Fig. 13.4** The location of the particle in SHM at the discrete values  $t = 0, T/4, T/2, 3T/4, T, 5T/4$ . The time after which motion repeats itself is  $T$ .  $T$  will remain fixed, no matter what location you choose as the initial ( $t = 0$ ) location. The speed is maximum for zero displacement (at  $x = 0$ ) and zero at the extremes of motion.

$\omega$  and  $\phi$  which characterize a given SHM have standard names, as summarised in Fig. 13.6. Let us understand these quantities.

The amplitude  $A$  of SHM is the magnitude of maximum displacement of the particle. [Note,  $A$  can be taken to be positive without

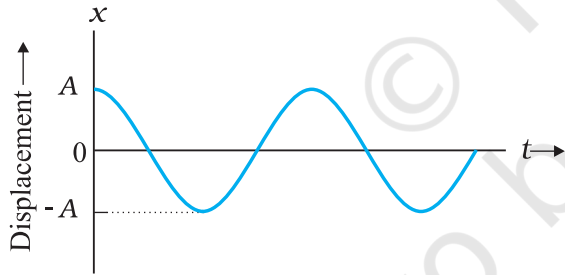

**Fig. 13.5** Displacement as a continuous function of time for simple harmonic motion.

$x(t)$	: displacement $x$ as a function of time $t$
$A$	: amplitude
$\omega$	: angular frequency
$\omega t + \phi$	: phase (time-dependent)
$\phi$	: phase constant

**Fig. 13.6** The meaning of standard symbols in Eq. (13.4)

any loss of generality]. As the cosine function of time varies from  $+1$  to  $-1$ , the displacement varies between the extremes  $A$  and  $-A$ . Two simple harmonic motions may have same  $\omega$  and  $\phi$  but different amplitudes  $A$  and  $B$ , as shown in Fig. 13.7 (a).

While the amplitude  $A$  is fixed for a given SHM, the state of motion (position and velocity) of the particle at any time  $t$  is determined by the

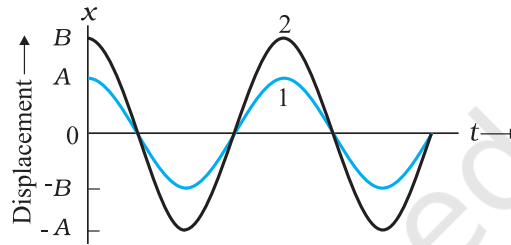

**Fig. 13.7 (a)** A plot of displacement as a function of time as obtained from Eq. (14.4) with  $\phi = 0$ . The curves 1 and 2 are for two different amplitudes  $A$  and  $B$ .

argument  $(\omega t + \phi)$  in the cosine function. This time-dependent quantity,  $(\omega t + \phi)$  is called the *phase* of the motion. The value of phase at  $t = 0$  is  $\phi$  and is called the *phase constant* (or *phase angle*). If the amplitude is known,  $\phi$  can be determined from the displacement at  $t = 0$ . Two simple harmonic motions may have the same  $A$  and  $\omega$  but different phase angle  $\phi$ , as shown in Fig. 13.7 (b).

Finally, the quantity  $\omega$  can be seen to be related to the period of motion  $T$ . Taking, for simplicity,  $\phi = 0$  in Eq. (13.4), we have

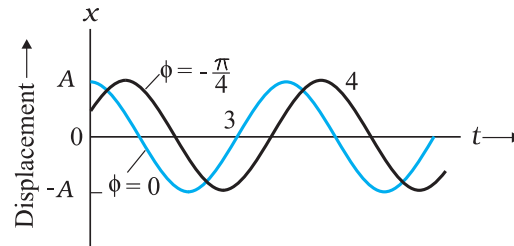

**Fig. 13.7 (b)** A plot obtained from Eq. (13.4). The curves 3 and 4 are for  $\phi = 0$  and  $-\pi/4$  respectively. The amplitude  $A$  is same for both the plots.



$$x(t) = A \cos \omega t \quad (13.5)$$

Since the motion has a period  $T$ ,  $x(t)$  is equal to  $x(t + T)$ . That is,

$$A \cos \omega t = A \cos \omega(t + T) \quad (13.6)$$

Now the cosine function is periodic with period  $2\pi$ , i.e., it first repeats itself when the argument changes by  $2\pi$ . Therefore,

$$\omega(t + T) = \omega t + 2\pi$$

$$\text{that is } \omega = 2\pi / T \quad (13.7)$$

$\omega$  is called the angular frequency of SHM. Its S.I. unit is radians per second. Since the frequency of oscillations is simply  $1/T$ ,  $\omega$  is  $2\pi$  times the frequency of oscillation. Two simple harmonic motions may have the same  $A$  and  $\phi$ , but different  $\omega$ , as seen in Fig. 13.8. In this plot the curve (b) has half the period and twice the frequency of the curve (a).

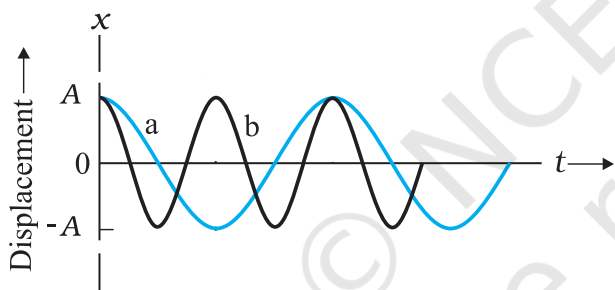

**Fig. 13.8** Plots of Eq. (13.4) for  $\phi = 0$  for two different periods.

**Example 13.3** Which of the following functions of time represent (a) simple harmonic motion and (b) periodic but not simple harmonic? Give the period for each case.

- (1)  $\sin \omega t - \cos \omega t$
- (2)  $\sin^2 \omega t$

**Answer**

$$\begin{aligned} \text{(a) } \sin \omega t - \cos \omega t &= \sin \omega t - \sin(\pi/2 - \omega t) \\ &= 2 \cos(\pi/4) \sin(\omega t - \pi/4) \\ &= \sqrt{2} \sin(\omega t - \pi/4) \end{aligned}$$

This function represents a simple harmonic motion having a period  $T = 2\pi/\omega$  and a phase angle  $(-\pi/4)$  or  $(7\pi/4)$

$$\begin{aligned} \text{(b) } \sin^2 \omega t &= \frac{1}{2} - \frac{1}{2} \cos 2\omega t \end{aligned}$$

The function is periodic having a period  $T = \pi/\omega$ . It also represents a harmonic motion with the point of equilibrium occurring at  $1/2$  instead of zero. ◀

### 13.4 SIMPLE HARMONIC MOTION AND UNIFORM CIRCULAR MOTION

In this section, we show that the projection of uniform circular motion on a diameter of the circle follows simple harmonic motion. A simple experiment (Fig. 13.9) helps us visualise this connection. Tie a ball to the end of a string and make it move in a horizontal plane about a fixed point with a constant angular speed. The ball would then perform a uniform circular motion in the horizontal plane. Observe the ball sideways or from the front, fixing your attention in the plane of motion. The ball will appear to execute to and fro motion along a horizontal line with the point of rotation as the midpoint. You could alternatively observe the shadow of the ball on a wall which is perpendicular to the plane of the circle. In this process what we are observing is the motion of the ball on a diameter of the circle normal to the direction of viewing.

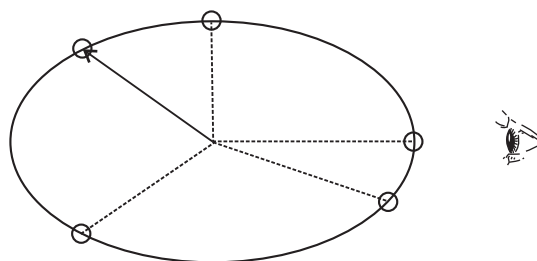

**Fig. 13.9** Circular motion of a ball in a plane viewed edge-on is SHM.

Fig. 13.10 describes the same situation mathematically. Suppose a particle  $P$  is moving uniformly on a circle of radius  $A$  with angular speed  $\omega$ . The sense of rotation is anticlockwise. The initial position vector of the particle, i.e., the vector  $\overline{OP}$  at  $t = 0$  makes an angle of  $\phi$  with the positive direction of  $x$ -axis. In time  $t$ , it will cover a further angle  $\omega t$  and its position vector

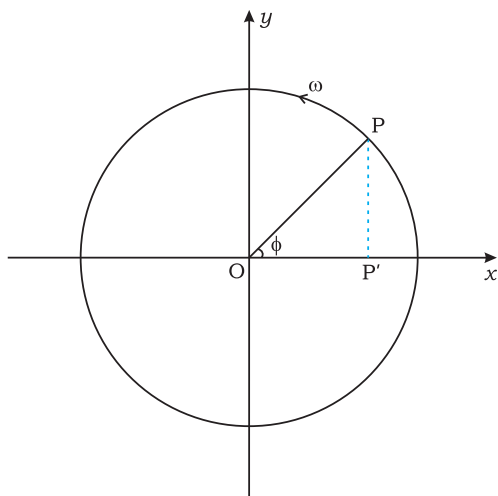

Fig. 13.10

will make an angle of  $\omega t + \phi$  with the +ve x-axis. Next, consider the projection of the position vector OP on the x-axis. This will be OP'. The position of P' on the x-axis, as the particle P moves on the circle, is given by

$$x(t) = A \cos (\omega t + \phi)$$

which is the defining equation of SHM. This shows that if P moves uniformly on a circle, its projection P' on a diameter of the circle executes SHM. The particle P and the circle on which it moves are sometimes referred to as the *reference particle* and the *reference circle*, respectively.

We can take projection of the motion of P on any diameter, say the y-axis. In that case, the displacement  $y(t)$  of P' on the y-axis is given by

$$y = A \sin (\omega t + \phi)$$

which is also an SHM of the same amplitude as that of the projection on x-axis, but differing by a phase of  $\pi/2$ .

In spite of this connection between circular motion and SHM, the force acting on a particle in linear simple harmonic motion is very different from the centripetal force needed to keep a particle in uniform circular motion.

**Example 13.4** The figure given below depicts two circular motions. The radius of the circle, the period of revolution, the initial position and the sense of revolution are indicated in the figures. Obtain the simple harmonic motions of the x-projection of the radius vector of the rotating particle P in each case.

**Answer**

- (a) At  $t = 0$ , OP makes an angle of  $45^\circ = \pi/4$  rad with the (positive direction of) x-axis. After time  $t$ , it covers an angle  $\frac{2\pi}{T}t$  in the anticlockwise sense, and makes an angle of  $\frac{2\pi}{T}t + \frac{\pi}{4}$  with the x-axis.

The projection of OP on the x-axis at time  $t$  is given by,

$$x(t) = A \cos \left( \frac{2\pi}{T}t + \frac{\pi}{4} \right)$$

For  $T = 4$  s,

$$x(t) = A \cos \left( \frac{2\pi}{4}t + \frac{\pi}{4} \right)$$

which is a SHM of amplitude  $A$ , period 4 s,

and an initial phase\* =  $\frac{\pi}{4}$ .

\* The natural unit of angle is radian, defined through the ratio of arc to radius. Angle is a dimensionless quantity. Therefore it is not always necessary to mention the unit 'radian' when we use  $\pi$ , its multiples or submultiples. The conversion between radian and degree is not similar to that between metre and centimetre or mile. If the argument of a trigonometric function is stated without units, it is understood that the unit is radian. On the other hand, if degree is to be used as the unit of angle, then it must be shown explicitly. For example,  $\sin(15^\circ)$  means sine of 15 degree, but  $\sin(15)$  means sine of 15 radians. Hereafter, we will often drop 'rad' as the unit, and it should be understood that whenever angle is mentioned as a numerical value, without units, it is to be taken as radians.

- (b) In this case at  $t = 0$ , OP makes an angle of  $90^\circ = \frac{\pi}{2}$  with the  $x$ -axis. After a time  $t$ , it covers an angle of  $\frac{2\pi}{T}t$  in the clockwise sense and makes an angle of  $\left(\frac{\pi}{2} - \frac{2\pi}{T}t\right)$  with the  $x$ -axis. The projection of OP on the  $x$ -axis at time  $t$  is given by

$$\begin{aligned} x(t) &= B \cos\left(\frac{\pi}{2} - \frac{2\pi}{T}t\right) \\ &= B \sin\left(\frac{2\pi}{T}t\right) \end{aligned}$$

For  $T = 30$  s,

$$x(t) = B \sin\left(\frac{\pi}{15}t\right)$$

Writing this as  $x(t) = B \cos\left(\frac{\pi}{15}t - \frac{\pi}{2}\right)$ , and comparing with Eq. (13.4). We find that this represents a SHM of amplitude  $B$ , period 30 s, and an initial phase of  $-\frac{\pi}{2}$ .

### 13.5 VELOCITY AND ACCELERATION IN SIMPLE HARMONIC MOTION

The speed of a particle  $v$  in uniform circular motion is its angular speed  $\omega$  times the radius of the circle  $A$ .

$$v = \omega A \quad (13.8)$$

The direction of velocity  $\vec{v}$  at a time  $t$  is along the tangent to the circle at the point where the particle is located at that instant. From the geometry of Fig. 13.11, it is clear that the velocity of the projection particle  $P'$  at time  $t$  is

$$v(t) = -\omega A \sin(\omega t + \phi) \quad (13.9)$$

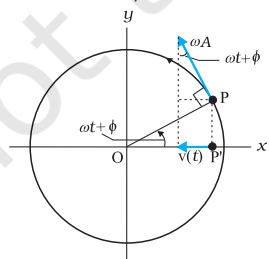

**Fig. 13.11** The velocity,  $v(t)$ , of the particle  $P'$  is the projection of the velocity  $\vec{v}$  of the reference particle,  $P$ .

where the negative sign shows that  $v(t)$  has a direction opposite to the positive direction of  $x$ -axis. Eq. (13.9) gives the instantaneous velocity of a particle executing SHM, where displacement is given by Eq. (13.4). We can, of course, obtain this equation without using geometrical argument, directly by differentiating (Eq. 13.4) with respect of  $t$ :

$$v(t) = \frac{d}{dt} x(t) \quad (13.10)$$

The method of reference circle can be similarly used for obtaining instantaneous acceleration of a particle undergoing SHM. We know that the centripetal acceleration of a particle  $P$  in uniform circular motion has a magnitude  $v^2/A$  or  $\omega^2 A$ , and it is directed towards the centre i.e., the direction is along  $PO$ . The instantaneous acceleration of the projection particle  $P'$  is then (See Fig. 13.12)

$$\begin{aligned} a(t) &= -\omega^2 A \cos(\omega t + \phi) \\ &= -\omega^2 x(t) \end{aligned} \quad (13.11)$$

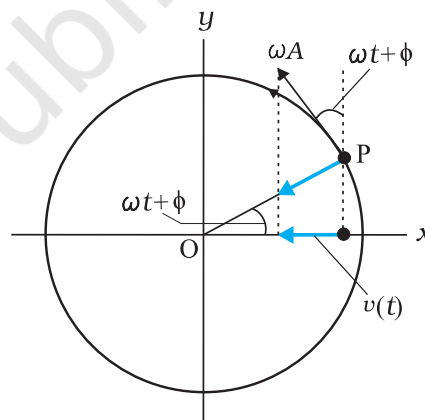

**Fig. 13.12** The acceleration,  $a(t)$ , of the particle  $P'$  is the projection of the acceleration  $\mathbf{a}$  of the reference particle  $P$ .

Eq. (13.11) gives the acceleration of a particle in SHM. The same equation can again be obtained directly by differentiating velocity  $v(t)$  given by Eq. (13.9) with respect to time:

$$a(t) = \frac{d}{dt} v(t) \quad (13.12)$$

We note from Eq. (13.11) the important property that acceleration of a particle in SHM is proportional to displacement. For  $x(t) > 0$ ,  $a(t) < 0$  and for  $x(t) < 0$ ,  $a(t) > 0$ . Thus, whatever

the value of  $x$  between  $-A$  and  $A$ , the acceleration  $a(t)$  is always directed towards the centre. For simplicity, let us put  $\phi = 0$  and write the expression for  $x(t)$ ,  $v(t)$  and  $a(t)$   
 $x(t) = A \cos \omega t$ ,  $v(t) = -\omega A \sin \omega t$ ,  $a(t) = -\omega^2 A \cos \omega t$   
 The corresponding plots are shown in Fig. 13.13. All quantities vary sinusoidally with time; only their maxima differ and the different plots differ in phase.  $x$  varies between  $-A$  to  $A$ ;  $v(t)$  varies from  $-\omega A$  to  $\omega A$  and  $a(t)$  from  $-\omega^2 A$  to  $\omega^2 A$ . With respect to displacement plot, velocity plot has a phase difference of  $\pi/2$  and acceleration plot has a phase difference of  $\pi$ .

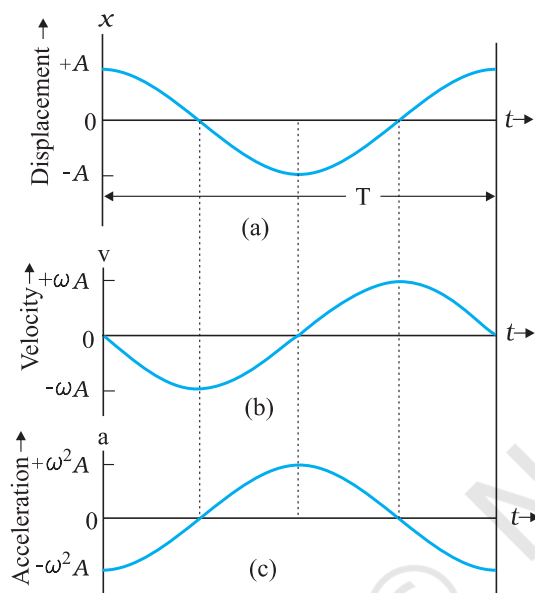

**Fig. 13.13** Displacement, velocity and acceleration of a particle in simple harmonic motion have the same period  $T$ , but they differ in phase

► **Example 13.5** A body oscillates with SHM according to the equation (in SI units),  
 $x = 5 \cos [2\pi t + \pi/4]$ .  
 At  $t = 1.5$  s, calculate the (a) displacement, (b) speed and (c) acceleration of the body.

**Answer** The angular frequency  $\omega$  of the body =  $2\pi \text{ s}^{-1}$  and its time period  $T = 1 \text{ s}$ .

At  $t = 1.5$  s

- (a) displacement =  $(5.0 \text{ m}) \cos [(2\pi \text{ s}^{-1}) \times 1.5 \text{ s} + \pi/4]$   
 $= (5.0 \text{ m}) \cos [(3\pi + \pi/4)]$   
 $= -5.0 \times 0.707 \text{ m}$   
 $= -3.535 \text{ m}$

- (b) Using Eq. (13.9), the speed of the body  
 $= -(5.0 \text{ m})(2\pi \text{ s}^{-1}) \sin [(2\pi \text{ s}^{-1}) \times 1.5 \text{ s} + \pi/4]$   
 $= -(5.0 \text{ m})(2\pi \text{ s}^{-1}) \sin [(3\pi + \pi/4)]$   
 $= 10\pi \times 0.707 \text{ m s}^{-1}$   
 $= 22 \text{ m s}^{-1}$
- (c) Using Eq.(13.10), the acceleration of the body  
 $= -(2\pi \text{ s}^{-1})^2 \times \text{displacement}$   
 $= -(2\pi \text{ s}^{-1})^2 \times (-3.535 \text{ m})$   
 $= 140 \text{ m s}^{-2}$

**13.6 FORCE LAW FOR SIMPLE HARMONIC MOTION**

Using Newton's second law of motion, and the expression for acceleration of a particle undergoing SHM (Eq. 13.11), the force acting on a particle of mass  $m$  in SHM is

$$F(t) = ma$$

$$= -m\omega^2 x(t)$$

i.e.,  $F(t) = -k x(t)$  (13.13)

where  $k = m\omega^2$  (13.14a)

or  $\omega = \sqrt{\frac{k}{m}}$  (13.14b)

Like acceleration, force is always directed towards the mean position—hence it is sometimes called the restoring force in SHM. To summarise the discussion so far, simple harmonic motion can be defined in two equivalent ways, either by Eq. (13.4) for displacement or by Eq. (13.13) that gives its force law. Going from Eq. (13.4) to Eq. (13.13) required us to differentiate two times. Likewise, by integrating the force law Eq. (13.13) two times, we can get back Eq. (13.4).

Note that the force in Eq. (13.13) is linearly proportional to  $x(t)$ . A particle oscillating under such a force is, therefore, calling a linear harmonic oscillator. In the real world, the force may contain small additional terms proportional to  $x^2$ ,  $x^3$ , etc. These then are called non-linear oscillators.

► **Example 13.6** Two identical springs of spring constant  $k$  are attached to a block of mass  $m$  and to fixed supports as shown in Fig. 13.14. Show that when the mass is displaced from its equilibrium position on either side, it executes a simple harmonic motion. Find the period of oscillations.

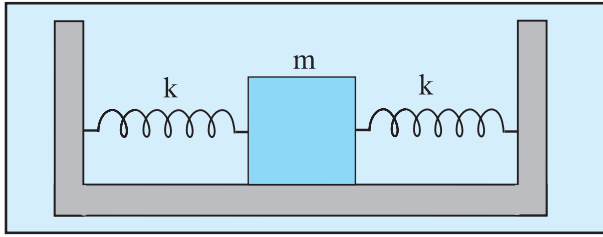

Fig. 13.14

**Answer** Let the mass be displaced by a small distance  $x$  to the right side of the equilibrium position, as shown in Fig. 13.15. Under this situation the spring on the left side gets

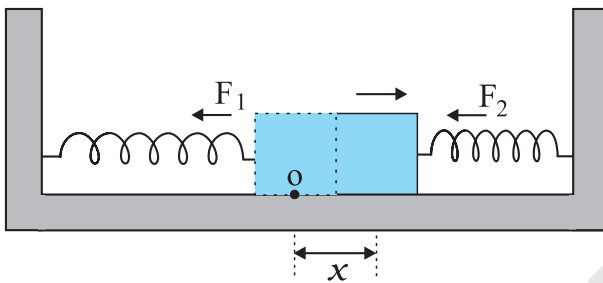

Fig. 13.15

elongated by a length equal to  $x$  and that on the right side gets compressed by the same length. The forces acting on the mass are then,

$$F_1 = -kx \text{ (force exerted by the spring on the left side, trying to pull the mass towards the mean position)}$$

$$F_2 = -kx \text{ (force exerted by the spring on the right side, trying to push the mass towards the mean position)}$$

The net force,  $F$ , acting on the mass is then given by,

$$F = -2kx$$

Hence the force acting on the mass is proportional to the displacement and is directed towards the mean position; therefore, the motion executed by the mass is simple harmonic. The time period of oscillations is,

$$T = 2\pi \sqrt{\frac{m}{2k}}$$

### 13.7 ENERGY IN SIMPLE HARMONIC MOTION

Both kinetic and potential energies of a particle in SHM vary between zero and their maximum values.

In section 13.5 we have seen that the velocity of a particle executing SHM, is a periodic function of time. It is zero at the extreme positions of displacement. Therefore, the kinetic energy ( $K$ ) of such a particle, which is defined as

$$\begin{aligned} K &= \frac{1}{2}mv^2 \\ &= \frac{1}{2}m\omega^2 A^2 \sin^2(\omega t + \phi) \\ &= \frac{1}{2}k A^2 \sin^2(\omega t + \phi) \end{aligned} \quad (13.15)$$

is also a periodic function of time, being zero when the displacement is maximum and maximum when the particle is at the mean position. Note, since the sign of  $v$  is immaterial in  $K$ , the period of  $K$  is  $T/2$ .

What is the potential energy ( $U$ ) of a particle executing simple harmonic motion? In Chapter 6, we have seen that the concept of potential energy is possible only for conservative forces. The spring force  $F = -kx$  is a conservative force, with associated potential energy

$$U = \frac{1}{2}kx^2 \quad (13.16)$$

Hence the potential energy of a particle executing simple harmonic motion is,

$$\begin{aligned} U(x) &= \frac{1}{2}kx^2 \\ &= \frac{1}{2}k A^2 \cos^2(\omega t + \phi) \end{aligned} \quad (13.17)$$

Thus, the potential energy of a particle executing simple harmonic motion is also periodic, with period  $T/2$ , being zero at the mean position and maximum at the extreme displacements.

It follows from Eqs. (13.15) and (13.17) that the total energy,  $E$ , of the system is,

$$\begin{aligned}
 E &= U + K \\
 &= \frac{1}{2} k A^2 \cos^2(\omega t + \phi) + \frac{1}{2} k A^2 \sin^2(\omega t + \phi) \\
 &= \frac{1}{2} k A^2 [\cos^2(\omega t + \phi) + \sin^2(\omega t + \phi)]
 \end{aligned}$$

Using the familiar trigonometric identity, the value of the expression in the brackets is unity. Thus,

$$E = \frac{1}{2} k A^2 \tag{13.18}$$

The total mechanical energy of a harmonic oscillator is thus independent of time as expected for motion under any conservative force. The time and displacement dependence of the potential and kinetic energies of a linear simple harmonic oscillator are shown in Fig. 13.16.

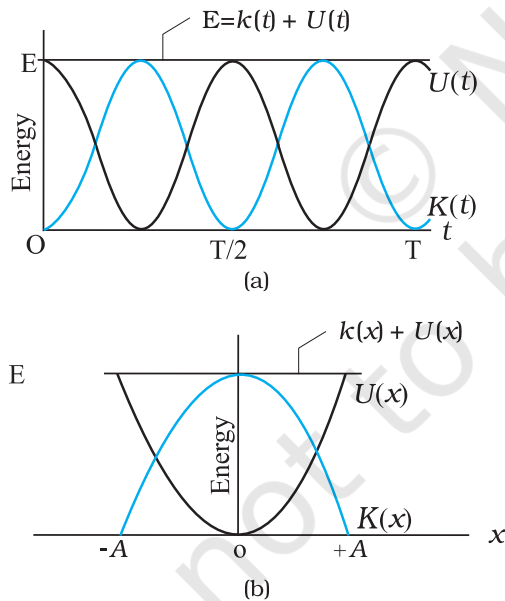

**Fig. 13.16** Kinetic energy, potential energy and total energy as a function of time [shown in (a)] and displacement [shown in (b)] of a particle in SHM. The kinetic energy and potential energy both repeat after a period  $T/2$ . The total energy remains constant at all  $t$  or  $x$ .

Observe that both kinetic energy and potential energy in SHM are seen to be always positive in Fig. 13.16. Kinetic energy can, of course, be never negative, since it is proportional to the square of speed. Potential energy is positive by choice of the undermined constant in potential energy. Both kinetic energy and potential energy peak twice during each period of SHM. For  $x = 0$ , the energy is kinetic; at the extremes  $x = \pm A$ , it is all potential energy. In the course of motion between these limits, kinetic energy increases at the expense of potential energy or vice-versa.

► **Example 13.7** A block whose mass is 1 kg is fastened to a spring. The spring has a spring constant of  $50 \text{ N m}^{-1}$ . The block is pulled to a distance  $x = 10 \text{ cm}$  from its equilibrium position at  $x = 0$  on a frictionless surface from rest at  $t = 0$ . Calculate the kinetic, potential and total energies of the block when it is 5 cm away from the mean position.

**Answer** The block executes SHM, its angular frequency, as given by Eq. (13.14b), is

$$\begin{aligned}
 \omega &= \sqrt{\frac{k}{m}} \\
 &= \sqrt{\frac{50 \text{ N m}^{-1}}{1 \text{ kg}}} \\
 &= 7.07 \text{ rad s}^{-1}
 \end{aligned}$$

Its displacement at any time  $t$  is then given by,

$$x(t) = 0.1 \cos(7.07 t)$$

Therefore, when the particle is 5 cm away from the mean position, we have

$$0.05 = 0.1 \cos(7.07 t)$$

Or  $\cos(7.07t) = 0.5$  and hence

$$\sin(7.07t) = \frac{\sqrt{3}}{2} = 0.866$$

Then, the velocity of the block at  $x = 5$  cm is

$$= 0.1 \times 7.07 \times 0.866 \text{ m s}^{-1}$$

$$= 0.61 \text{ m s}^{-1}$$

Hence the K.E. of the block,

$$\begin{aligned} &= \frac{1}{2} m v^2 \\ &= \frac{1}{2} [1 \text{ kg} \times (0.6123 \text{ m s}^{-1})^2] \\ &= 0.19 \text{ J} \end{aligned}$$

The P.E. of the block,

$$\begin{aligned} &= \frac{1}{2} k x^2 \\ &= \frac{1}{2} (50 \text{ N m}^{-1} \times 0.05 \text{ m} \times 0.05 \text{ m}) \\ &= 0.0625 \text{ J} \end{aligned}$$

The total energy of the block at  $x = 5$  cm,

$$\begin{aligned} &= \text{K.E.} + \text{P.E.} \\ &= 0.25 \text{ J} \end{aligned}$$

we also know that at maximum displacement, K.E. is zero and hence the total energy of the system is equal to the P.E. Therefore, the total energy of the system,

$$\begin{aligned} &= \frac{1}{2} (50 \text{ N m}^{-1} \times 0.1 \text{ m} \times 0.1 \text{ m}) \\ &= 0.25 \text{ J} \end{aligned}$$

which is same as the sum of the two energies at a displacement of 5 cm. This is in conformity with the principle of conservation of energy. ◀

### 13.8 The Simple Pendulum

It is said that Galileo measured the periods of a swinging chandelier in a church by his pulse beats. He observed that the motion of the chandelier was periodic. The system is a kind of pendulum. You can also make your own pendulum by tying a piece of stone to a long unstretchable thread, approximately 100 cm long. Suspend your pendulum from a suitable support so that it is free to oscillate. Displace the stone to one side by a small distance and

let it go. The stone executes a to and fro motion, it is periodic with a period of about two seconds.

We shall show that this periodic motion is simple harmonic for small displacements from

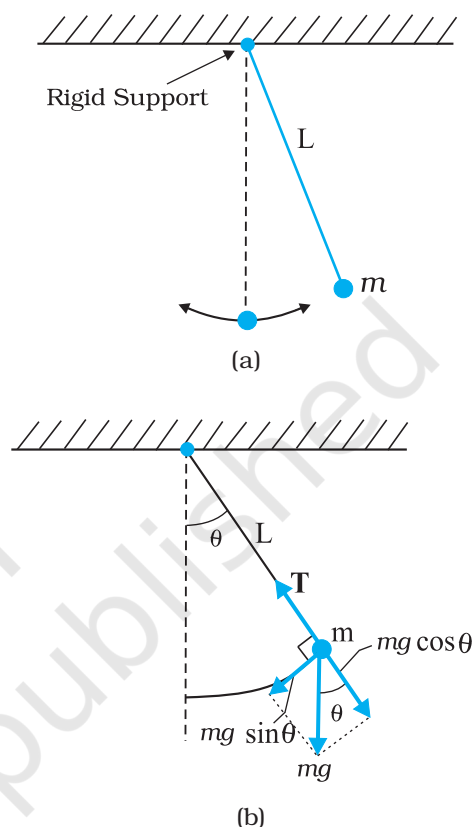

**Fig. 13.17** (a) A bob oscillating about its mean position. (b) The radial force  $T - mg \cos \theta$  provides centripetal force but no torque about the support. The tangential force  $mg \sin \theta$  provides the restoring torque.

the mean position. Consider simple pendulum — a small bob of mass  $m$  tied to an inextensible massless string of length  $L$ . The other end of the string is fixed to a rigid support. The bob oscillates in a plane about the vertical line through the support. Fig. 13.17(a) shows this system. Fig. 13.17(b) is a kind of ‘free-body’ diagram of the simple pendulum showing the forces acting on the bob.

Let  $\theta$  be the angle made by the string with the vertical. When the bob is at the mean position,  $\theta = 0$

There are only two forces acting on the bob; the tension  $T$  along the string and the vertical

force due to gravity ( $=mg$ ). The force  $mg$  can be resolved into the component  $mg \cos\theta$  along the string and  $mg \sin\theta$  perpendicular to it. Since the motion of the bob is along a circle of length  $L$  and centre at the support point, the bob has a radial acceleration ( $\omega^2 L$ ) and also a tangential acceleration; the latter arises since motion along the arc of the circle is not uniform. The radial acceleration is provided by the net radial force  $T - mg \cos\theta$ , while the tangential acceleration is provided by  $mg \sin\theta$ . It is more convenient to work with torque about the support since the radial force gives zero torque. Torque  $\tau$  about the support is entirely provided by the tangential component of force

$$\tau = -L(mg \sin\theta) \tag{13.19}$$

This is the restoring torque that tends to reduce angular displacement — hence the negative sign. By Newton’s law of rotational motion,

$$\tau = I\alpha \tag{13.20}$$

where  $I$  is the moment of inertia of the system about the support and  $\alpha$  is the angular acceleration. Thus,

$$I\alpha = -mg \sin\theta L \tag{13.21}$$

Or,

$$\alpha = -\frac{mgL}{I} \sin\theta \tag{13.22}$$

We can simplify Eq. (13.22) if we assume that the displacement  $\theta$  is small. We know that  $\sin\theta$  can be expressed as,

$$\sin\theta = \theta - \frac{\theta^3}{3!} + \frac{\theta^5}{5!} \pm \dots \tag{13.23}$$

where  $\theta$  is in radians.

Now if  $\theta$  is small,  $\sin\theta$  can be approximated by  $\theta$  and Eq. (13.22) can then be written as,

$$\alpha = -\frac{mgL}{I} \theta \tag{13.24}$$

In Table 13.1, we have listed the angle  $\theta$  in degrees, its equivalent in radians, and the value of the function  $\sin\theta$ . From this table it can be seen that for  $\theta$  as large as 20 degrees,  $\sin\theta$  is nearly the same as  $\theta$  **expressed in radians**.

**Table 13.1**  $\sin\theta$  as a function of angle  $\theta$

$\theta$ (degrees)	$\theta$ (radians)	$\sin\theta$
0	0	0
5	0.087	0.087
10	0.174	0.174
15	0.262	0.259
20	0.349	0.342

Equation (13.24) is mathematically, identical to Eq. (13.11) except that the variable is angular displacement. Hence we have proved that for small  $\theta$ , the motion of the bob is simple harmonic. From Eqs. (13.24) and (13.11),

$$\omega = \sqrt{\frac{mgL}{I}}$$

and

$$T = 2\pi \sqrt{\frac{I}{mgL}} \tag{13.25}$$

Now since the string of the simple pendulum is massless, the moment of inertia  $I$  is simply  $mL^2$ . Eq. (13.25) then gives the well-known formula for time period of a simple pendulum.

$$T = 2\pi \sqrt{\frac{L}{g}} \tag{13.26}$$

**Example 13.8** What is the length of a simple pendulum, which ticks seconds?

**Answer** From Eq. (13.26), the time period of a simple pendulum is given by,

$$T = 2\pi \sqrt{\frac{L}{g}}$$

From this relation one gets,

$$L = \frac{gT^2}{4\pi^2}$$

The time period of a simple pendulum, which ticks seconds, is 2 s. Therefore, for  $g = 9.8 \text{ m s}^{-2}$

$$\begin{aligned} \text{and } T = 2 \text{ s, } L \text{ is} \\ &= \frac{9.8(\text{m s}^{-2}) \times 4(\text{s}^2)}{4\pi^2} \\ &= 1 \text{ m} \end{aligned}$$



## SUMMARY

1. The motion that repeats itself is called *periodic motion*.
2. The *period*  $T$  is the time required for one complete oscillation, or cycle. It is related to the frequency  $\nu$  by,

$$T = \frac{1}{\nu}$$

The *frequency*  $\nu$  of periodic or oscillatory motion is the number of oscillations per unit time. In the SI, it is measured in hertz :

$$1 \text{ hertz} = 1 \text{ Hz} = 1 \text{ oscillation per second} = 1 \text{ s}^{-1}$$

3. In *simple harmonic motion* (SHM), the displacement  $x(t)$  of a particle from its equilibrium position is given by,

$$x(t) = A \cos(\omega t + \phi) \quad (\text{displacement}),$$

in which  $A$  is the *amplitude* of the displacement, the quantity  $(\omega t + \phi)$  is the phase of the motion, and  $\phi$  is the *phase constant*. The *angular frequency*  $\omega$  is related to the period and frequency of the motion by,

$$\omega = \frac{2\pi}{T} = 2\pi\nu \quad (\text{angular frequency}).$$

4. Simple harmonic motion can also be viewed as the projection of uniform circular motion on the diameter of the circle in which the latter motion occurs.
5. The particle velocity and acceleration during SHM as functions of time are given by,

$$v(t) = -\omega A \sin(\omega t + \phi) \quad (\text{velocity}),$$

$$\begin{aligned} a(t) &= -\omega^2 A \cos(\omega t + \phi) \\ &= -\omega^2 x(t) \quad (\text{acceleration}), \end{aligned}$$

Thus we see that both velocity and acceleration of a body executing simple harmonic motion are periodic functions, having the velocity *amplitude*  $v_m = \omega A$  and *acceleration amplitude*  $a_m = \omega^2 A$ , respectively.

6. The force acting in a simple harmonic motion is proportional to the displacement and is always directed towards the centre of motion.
7. A particle executing simple harmonic motion has, at any time, kinetic energy  $K = \frac{1}{2} mv^2$  and potential energy  $U = \frac{1}{2} kx^2$ . If no friction is present the mechanical energy of the system,  $E = K + U$  always remains constant even though  $K$  and  $U$  change with time.
8. A particle of mass  $m$  oscillating under the influence of Hooke's law restoring force given by  $F = -kx$  exhibits simple harmonic motion with

$$\omega = \sqrt{\frac{k}{m}} \quad (\text{angular frequency})$$

$$T = 2\pi\sqrt{\frac{m}{k}} \quad (\text{period})$$

Such a system is also called a linear oscillator.

9. The motion of a simple pendulum swinging through small angles is approximately simple harmonic. The period of oscillation is given by,

$$T = 2\pi\sqrt{\frac{L}{g}}$$

Physical quantity	Symbol	Dimensions	Unit	Remarks
Period	$T$	[T]	s	The least time for motion to repeat itself
Frequency	$\nu$ (or $f$ )	[T <sup>-1</sup> ]	s <sup>-1</sup>	$\nu = \frac{1}{T}$
Angular frequency	$\omega$	[T <sup>-1</sup> ]	s <sup>-1</sup>	$\omega = 2\pi\nu$
Phase constant	$\phi$	Dimensionless	rad	Initial value of phase of displacement in SHM
Force constant	$k$	[MT <sup>-2</sup> ]	N m <sup>-1</sup>	Simple harmonic motion $F = -kx$

### POINTS TO PONDER

- The period  $T$  is the *least time* after which motion repeats itself. Thus, motion repeats itself after  $nT$  where  $n$  is an integer.
- Every periodic motion is not simple harmonic motion. Only that periodic motion governed by the force law  $F = -kx$  is simple harmonic.
- Circular motion can arise due to an inverse-square law force (as in planetary motion) as well as due to simple harmonic force in two dimensions equal to:  $-m\omega^2r$ . In the latter case, the phases of motion, in two perpendicular directions ( $x$  and  $y$ ) must differ by  $\pi/2$ . Thus, for example, a particle subject to a force  $-m\omega^2r$  with initial position  $(0, A)$  and velocity  $(\omega A, 0)$  will move uniformly in a circle of radius  $A$ .
- For linear simple harmonic motion with a given  $\omega$ , two initial conditions are necessary and sufficient to determine the motion completely. The initial conditions may be (i) initial position and initial velocity or (ii) amplitude and phase or (iii) energy and phase.
- From point 4 above, given amplitude or energy, phase of motion is determined by the initial position or initial velocity.
- A combination of two simple harmonic motions with arbitrary amplitudes and phases is not necessarily periodic. It is periodic only if frequency of one motion is an integral multiple of the other's frequency. However, a periodic motion can always be expressed as a sum of infinite number of harmonic motions with appropriate amplitudes.
- The period of SHM does not depend on amplitude or energy or the phase constant. Contrast this with the periods of planetary orbits under gravitation (Kepler's third law).
- The motion of a simple pendulum is simple harmonic for small angular displacement.
- For motion of a particle to be simple harmonic, its displacement  $x$  must be expressible in either of the following forms :

$$x = A \cos \omega t + B \sin \omega t$$

$$x = A \cos (\omega t + \alpha), \quad x = B \sin (\omega t + \beta)$$

The three forms are completely equivalent (any one can be expressed in terms of any other two forms).

Thus, damped simple harmonic motion is not strictly simple harmonic. It is approximately so only for time intervals much less than  $2m/b$  where  $b$  is the damping constant.

## Exercises

- 13.1** Which of the following examples represent periodic motion?
- A swimmer completing one (return) trip from one bank of a river to the other and back.
  - A freely suspended bar magnet displaced from its N-S direction and released.
  - A hydrogen molecule rotating about its centre of mass.
  - An arrow released from a bow.
- 13.2** Which of the following examples represent (nearly) simple harmonic motion and which represent periodic but not simple harmonic motion?
- the rotation of earth about its axis.
  - motion of an oscillating mercury column in a U-tube.
  - motion of a ball bearing inside a smooth curved bowl, when released from a point slightly above the lower most point.
  - general vibrations of a polyatomic molecule about its equilibrium position.
- 13.3** Fig. 13.18 depicts four  $x-t$  plots for linear motion of a particle. Which of the plots represent periodic motion? What is the period of motion (in case of periodic motion) ?

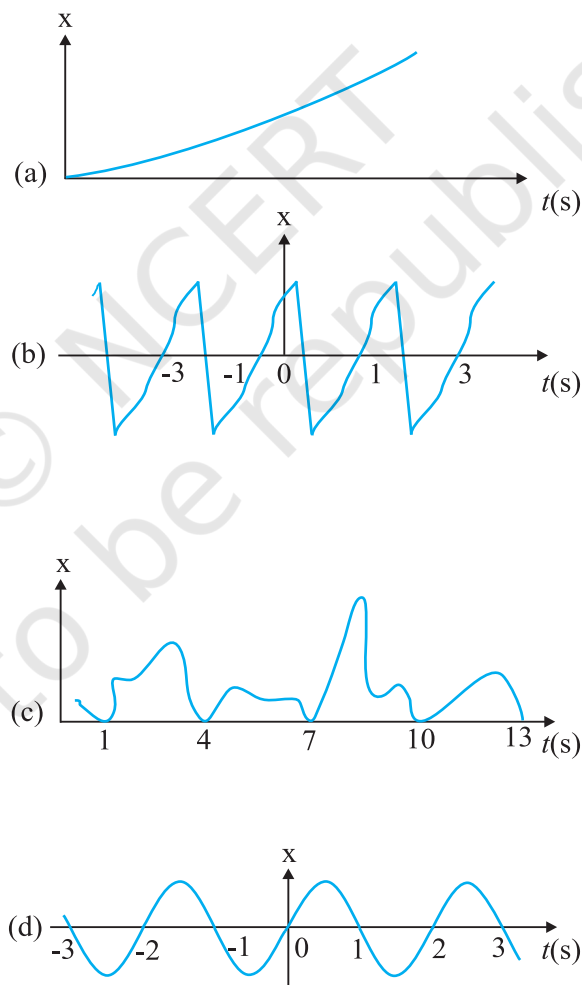
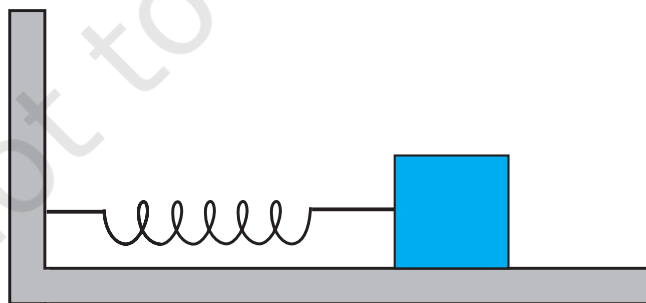

Fig. 18.18

- 13.4** Which of the following functions of time represent (a) simple harmonic, (b) periodic but not simple harmonic, and (c) non-periodic motion? Give period for each case of periodic motion ( $\omega$  is any positive constant):
- $\sin \omega t - \cos \omega t$
  - $\sin^3 \omega t$
  - $3 \cos (\pi/4 - 2\omega t)$
  - $\cos \omega t + \cos 3\omega t + \cos 5\omega t$
  - $\exp (-\omega^2 t^2)$
  - $1 + \omega t + \omega^2 t^2$
- 13.5** A particle is in linear simple harmonic motion between two points, A and B, 10 cm apart. Take the direction from A to B as the positive direction and give the signs of velocity, acceleration and force on the particle when it is
- at the end A,
  - at the end B,
  - at the mid-point of AB going towards A,
  - at 2 cm away from B going towards A,
  - at 3 cm away from A going towards B, and
  - at 4 cm away from B going towards A.
- 13.6** Which of the following relationships between the acceleration  $a$  and the displacement  $x$  of a particle involve simple harmonic motion?
- $a = 0.7x$
  - $a = -200x^2$
  - $a = -10x$
  - $a = 100x^3$
- 13.7** The motion of a particle executing simple harmonic motion is described by the displacement function,
- $$x(t) = A \cos (\omega t + \phi).$$
- If the initial ( $t = 0$ ) position of the particle is 1 cm and its initial velocity is  $\omega$  cm/s, what are its amplitude and initial phase angle? The angular frequency of the particle is  $\pi \text{ s}^{-1}$ . If instead of the cosine function, we choose the sine function to describe the SHM :  $x = B \sin (\omega t + \alpha)$ , what are the amplitude and initial phase of the particle with the above initial conditions.
- 13.8** A spring balance has a scale that reads from 0 to 50 kg. The length of the scale is 20 cm. A body suspended from this balance, when displaced and released, oscillates with a period of 0.6 s. What is the weight of the body?
- 13.9** A spring having with a spring constant  $1200 \text{ N m}^{-1}$  is mounted on a horizontal table as shown in Fig. 13.19. A mass of 3 kg is attached to the free end of the spring. The mass is then pulled sideways to a distance of 2.0 cm and released.



**Fig. 13.19**

Determine (i) the frequency of oscillations, (ii) maximum acceleration of the mass, and (iii) the maximum speed of the mass.

- 13.10** In Exercise 13.9, let us take the position of mass when the spring is unstretched as  $x = 0$ , and the direction from left to right as the positive direction of  $x$ -axis. Give  $x$  as a function of time  $t$  for the oscillating mass if at the moment we start the stopwatch ( $t = 0$ ), the mass is
- at the mean position,
  - at the maximum stretched position, and
  - at the maximum compressed position.
- In what way do these functions for SHM differ from each other, in frequency, in amplitude or the initial phase?
- 13.11** Figures 13.20 correspond to two circular motions. The radius of the circle, the period of revolution, the initial position, and the sense of revolution (i.e. clockwise or anti-clockwise) are indicated on each figure.

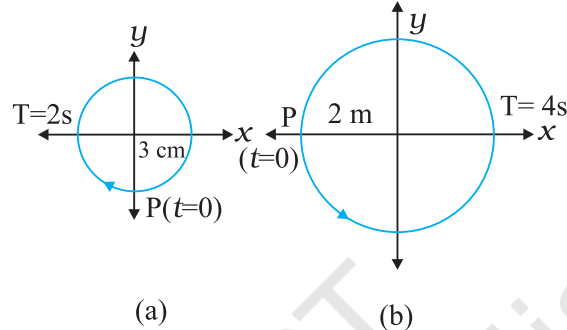
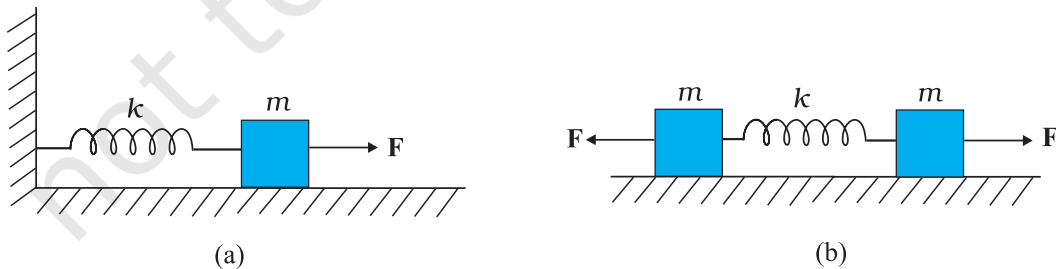

**Fig. 13.20**

Obtain the corresponding simple harmonic motions of the  $x$ -projection of the radius vector of the revolving particle  $P$ , in each case.

- 13.12** Plot the corresponding reference circle for each of the following simple harmonic motions. Indicate the initial ( $t = 0$ ) position of the particle, the radius of the circle, and the angular speed of the rotating particle. For simplicity, the sense of rotation may be fixed to be anticlockwise in every case: ( $x$  is in cm and  $t$  is in s).
- $x = -2 \sin(3t + \pi/3)$
  - $x = \cos(\pi/6 - t)$
  - $x = 3 \sin(2\pi t + \pi/4)$
  - $x = 2 \cos \pi t$

- 13.13** Figure 13.21(a) shows a spring of force constant  $k$  clamped rigidly at one end and a mass  $m$  attached to its free end. A force  $\mathbf{F}$  applied at the free end stretches the spring. Figure 13.21 (b) shows the same spring with both ends free and attached to a mass  $m$  at either end. Each end of the spring in Fig. 13.21(b) is stretched by the same force  $\mathbf{F}$ .



**Fig. 13.21**

- What is the maximum extension of the spring in the two cases ?
- If the mass in Fig. (a) and the two masses in Fig. (b) are released, what is the period of oscillation in each case ?

- 13.14** The piston in the cylinder head of a locomotive has a stroke (twice the amplitude) of 1.0 m. If the piston moves with simple harmonic motion with an angular frequency of 200 rad/min, what is its maximum speed ?
- 13.15** The acceleration due to gravity on the surface of moon is  $1.7 \text{ m s}^{-2}$ . What is the time period of a simple pendulum on the surface of moon if its time period on the surface of earth is 3.5 s ? ( $g$  on the surface of earth is  $9.8 \text{ m s}^{-2}$ )
- 13.16** A simple pendulum of length  $l$  and having a bob of mass  $M$  is suspended in a car. The car is moving on a circular track of radius  $R$  with a uniform speed  $v$ . If the pendulum makes small oscillations in a radial direction about its equilibrium position, what will be its time period ?
- 13.17** A cylindrical piece of cork of density of base area  $A$  and height  $h$  floats in a liquid of density  $\rho_l$ . The cork is depressed slightly and then released. Show that the cork oscillates up and down simple harmonically with a period

$$T = 2\pi \sqrt{\frac{h\rho}{\rho_l g}}$$

where  $\rho$  is the density of cork. (Ignore damping due to viscosity of the liquid).

- 13.18** One end of a U-tube containing mercury is connected to a suction pump and the other end to atmosphere. A small pressure difference is maintained between the two columns. Show that, when the suction pump is removed, the column of mercury in the U-tube executes simple harmonic motion.



## WAVES

- 14.1 Introduction
- 14.2 Transverse and longitudinal waves
- 14.3 Displacement relation in a progressive wave
- 14.4 The speed of a travelling wave
- 14.5 The principle of superposition of waves
- 14.6 Reflection of waves
- 14.7 Beats
- Summary
- Points to ponder
- Exercises

### 14.1 INTRODUCTION

In the previous Chapter, we studied the motion of objects oscillating in isolation. What happens in a system, which is a collection of such objects? A material medium provides such an example. Here, elastic forces bind the constituents to each other and, therefore, the motion of one affects that of the other. If you drop a little pebble in a pond of still water, the water surface gets disturbed. The disturbance does not remain confined to one place, but propagates outward along a circle. If you continue dropping pebbles in the pond, you see circles rapidly moving outward from the point where the water surface is disturbed. It gives a feeling as if the water is moving outward from the point of disturbance. If you put some cork pieces on the disturbed surface, it is seen that the cork pieces move up and down but do not move away from the centre of disturbance. This shows that the water mass does not flow outward with the circles, but rather a moving disturbance is created. Similarly, when we speak, the sound moves outward from us, without any flow of air from one part of the medium to another. The disturbances produced in air are much less obvious and only our ears or a microphone can detect them. These patterns, which move without the actual physical transfer or flow of matter as a whole, are called **waves**. In this Chapter, we will study such waves.

Waves transport energy and the pattern of disturbance has information that propagate from one point to another. All our communications essentially depend on transmission of signals through waves. Speech means production of sound waves in air and hearing amounts to their detection. Often, communication involves different kinds of waves. For example, sound waves may be first converted into an electric current signal which in turn may generate an electromagnetic wave that may be transmitted by an optical cable or via a

satellite. Detection of the original signal will usually involve these steps in reverse order.

Not all waves require a medium for their propagation. We know that light waves can travel through vacuum. The light emitted by stars, which are hundreds of light years away, reaches us through inter-stellar space, which is practically a vacuum.

The most familiar type of waves such as waves on a string, water waves, sound waves, seismic waves, etc. is the so-called mechanical waves. These waves require a medium for propagation, they cannot propagate through vacuum. They involve oscillations of constituent particles and depend on the elastic properties of the medium. The electromagnetic waves that you will learn in Class XII are a different type of wave. Electromagnetic waves do not necessarily require a medium - they can travel through vacuum. Light, radiowaves, X-rays, are all electromagnetic waves. In vacuum, all electromagnetic waves have the same speed  $c$ , whose value is :

$$c = 299, 792, 458 \text{ ms}^{-1}. \quad (14.1)$$

A third kind of wave is the so-called Matter waves. They are associated with constituents of matter : electrons, protons, neutrons, atoms and molecules. They arise in quantum mechanical description of nature that you will learn in your later studies. Though conceptually more abstract than mechanical or electro-magnetic waves, they have already found applications in several devices basic to modern technology; matter waves associated with electrons are employed in electron microscopes.

In this chapter we will study mechanical waves, which require a material medium for their propagation.

The aesthetic influence of waves on art and literature is seen from very early times; yet the first scientific analysis of wave motion dates back to the seventeenth century. Some of the famous scientists associated with the physics of wave motion are Christiaan Huygens (1629-1695), Robert Hooke and Isaac Newton. The understanding of physics of waves followed the physics of oscillations of masses tied to springs and physics of the simple pendulum. Waves in elastic media are intimately connected with harmonic oscillations. (Stretched strings, coiled springs, air, etc., are examples of elastic media).

We shall illustrate this connection through simple examples.

Consider a collection of springs connected to one another as shown in Fig. 14.1. If the spring at one end is pulled suddenly and released, the disturbance travels to the other end. What has



**Fig. 14.1** A collection of springs connected to each other. The end A is pulled suddenly generating a disturbance, which then propagates to the other end.

happened? The first spring is disturbed from its equilibrium length. Since the second spring is connected to the first, it is also stretched or compressed, and so on. The disturbance moves from one end to the other; but each spring only executes small oscillations about its equilibrium position. As a practical example of this situation, consider a stationary train at a railway station. Different bogies of the train are coupled to each other through a spring coupling. When an engine is attached at one end, it gives a push to the bogie next to it; this push is transmitted from one bogie to another without the entire train being bodily displaced.

Now let us consider the propagation of sound waves in air. As the wave passes through air, it compresses or expands a small region of air. This causes a change in the density of that region, say  $\delta\rho$ , this change induces a change in pressure,  $\delta p$ , in that region. Pressure is force per unit area, so there is a **restoring force proportional** to the disturbance, just like in a spring. In this case, the quantity similar to extension or compression of the spring is the change in density. If a region is compressed, the molecules in that region are packed together, and they tend to move out to the adjoining region, thereby increasing the density or creating compression in the adjoining region. Consequently, the air in the first region undergoes rarefaction. If a region is comparatively rarefied the surrounding air will rush in making the rarefaction move to the adjoining region. Thus, the compression or rarefaction moves from one region to another, making the propagation of a disturbance possible in air.



In solids, similar arguments can be made. In a crystalline solid, atoms or group of atoms are arranged in a periodic lattice. In these, each atom or group of atoms is in equilibrium, due to forces from the surrounding atoms. Displacing one atom, keeping the others fixed, leads to restoring forces, exactly as in a spring. So we can think of atoms in a lattice as end points, with springs between pairs of them.

In the subsequent sections of this chapter we are going to discuss various characteristic properties of waves.

## 14.2 TRANSVERSE AND LONGITUDINAL WAVES

We have seen that motion of mechanical waves involves oscillations of constituents of the medium. If the constituents of the medium oscillate perpendicular to the direction of wave propagation, we call the wave a transverse wave. If they oscillate along the direction of wave propagation, we call the wave a longitudinal wave.

Fig. 14.2 shows the propagation of a single pulse along a string, resulting from a single up and down jerk. If the string is very long compared

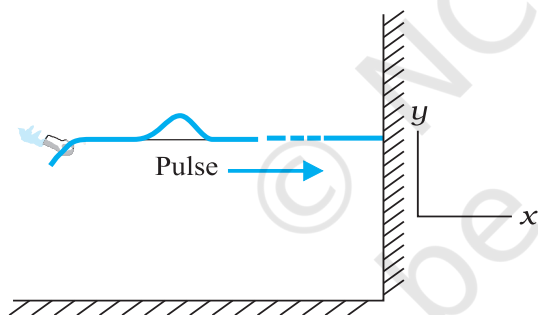

**Fig. 14.2** When a pulse travels along the length of a stretched string ( $x$ -direction), the elements of the string oscillate up and down ( $y$ -direction)

to the size of the pulse, the pulse will damp out before it reaches the other end and reflection from that end may be ignored. Fig. 14.3 shows a similar situation, but this time the external agent gives a continuous periodic sinusoidal up and down jerk to one end of the string. The resulting disturbance on the string is then a sinusoidal wave. In either case the elements of the string oscillate about their equilibrium mean

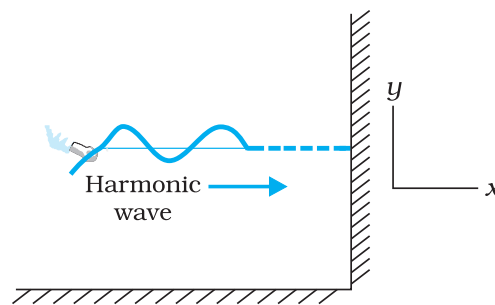

**Fig. 14.3** A harmonic (sinusoidal) wave travelling along a stretched string is an example of a transverse wave. An element of the string in the region of the wave oscillates about its equilibrium position perpendicular to the direction of wave propagation.

position as the pulse or wave passes through them. The oscillations are normal to the direction of wave motion along the string, so this is an example of transverse wave.

We can look at a wave in two ways. We can fix an instant of time and picture the wave in space. This will give us the shape of the wave as a whole in space at a given instant. Another way is to fix a location i.e. fix our attention on a particular element of string and see its oscillatory motion in time.

Fig. 14.4 describes the situation for longitudinal waves in the most familiar example of the propagation of sound waves. A long pipe filled with air has a piston at one end. A single sudden push forward and pull back of the piston will generate a pulse of condensations (higher density) and rarefactions (lower density) in the medium (air). If the push-pull of the piston is continuous and periodic (sinusoidal), a



**Fig. 14.4** Longitudinal waves (sound) generated in a pipe filled with air by moving the piston up and down. A volume element of air oscillates in the direction parallel to the direction of wave propagation.

sinusoidal wave will be generated propagating in air along the length of the pipe. This is clearly an example of longitudinal waves.

The waves considered above, transverse or longitudinal, are travelling or progressive waves since they travel from one part of the medium to another. The material medium as a whole does not move, as already noted. A stream, for example, constitutes motion of water as a whole. In a water wave, it is the disturbance that moves, not water as a whole. Likewise a wind (motion of air as a whole) should not be confused with a sound wave which is a propagation of disturbance (in pressure density) in air, without the motion of air medium as a whole.

In transverse waves, the particle motion is normal to the direction of propagation of the wave. Therefore, as the wave propagates, each element of the medium undergoes a shearing strain. Transverse waves can, therefore, be propagated only in those media, which can sustain shearing stress, such as solids and not in fluids. Fluids, as well as, solids can sustain compressive strain; therefore, longitudinal waves can be propagated in all elastic media. For example, in medium like steel, both transverse and longitudinal waves can propagate, while air can sustain only longitudinal waves. The waves on the surface of water are of two kinds: **capillary waves** and **gravity waves**. The former are ripples of fairly short wavelength—not more than a few centimetre—and the restoring force that produces them is the surface tension of water. Gravity waves have wavelengths typically ranging from several metres to several hundred meters. The restoring force that produces these waves is the pull of gravity, which tends to keep the water surface at its lowest level. The oscillations of the particles in these waves are not confined to the surface only, but extend with diminishing amplitude to the very bottom. The particle motion in water waves involves a complicated motion—they not only move up and down but also back and forth. The waves in an ocean are the combination of both longitudinal and transverse waves.

It is found that, generally, transverse and longitudinal waves travel with different speed in the same medium.

► **Example 14.1** Given below are some examples of wave motion. State in each case if the wave motion is transverse, longitudinal or a combination of both:

- Motion of a kink in a longitudinal spring produced by displacing one end of the spring sideways.
- Waves produced in a cylinder containing a liquid by moving its piston back and forth.
- Waves produced by a motorboat sailing in water.
- Ultrasonic waves in air produced by a vibrating quartz crystal.

**Answer**

- Transverse and longitudinal
- Longitudinal
- Transverse and longitudinal
- Longitudinal

### 14.3 DISPLACEMENT RELATION IN A PROGRESSIVE WAVE

For mathematical description of a travelling wave, we need a function of both position  $x$  and time  $t$ . Such a function at every instant should give the shape of the wave at that instant. Also, at every given location, it should describe the motion of the constituent of the medium at that location. If we wish to describe a sinusoidal travelling wave (such as the one shown in Fig. 14.3) the corresponding function must also be sinusoidal. For convenience, we shall take the wave to be transverse so that if the position of the constituents of the medium is denoted by  $x$ , the displacement from the equilibrium position may be denoted by  $y$ . A sinusoidal travelling wave is then described by:

$$y(x, t) = a \sin(kx - \omega t + \phi) \quad (14.2)$$

The term  $\phi$  in the argument of sine function means equivalently that we are considering a linear combination of sine and cosine functions:

$$y(x, t) = A \sin(kx - \omega t) + B \cos(kx - \omega t) \quad (14.3)$$

From Equations (14.2) and (14.3),

$$a = \sqrt{A^2 + B^2} \quad \text{and} \quad \phi = \tan^{-1} \left( \frac{B}{A} \right)$$

To understand why Equation (14.2) represents a sinusoidal travelling wave, take a fixed instant, say  $t = t_0$ . Then, the argument of the sine function in Equation (14.2) is simply

$kx + \text{constant}$ . Thus, the shape of the wave (at any fixed instant) as a function of  $x$  is a sine wave. Similarly, take a fixed location, say  $x = x_0$ . Then, the argument of the sine function in Equation (14.2) is constant  $-\omega t$ . The displacement  $y$ , at a fixed location, thus, varies sinusoidally with time. That is, the constituents of the medium at different positions execute simple harmonic motion. Finally, as  $t$  increases,  $x$  must increase in the positive direction to keep  $kx - \omega t + \phi$  constant. Thus, Eq. (14.2) represents a sinusoidal (harmonic) wave travelling along the positive direction of the  $x$ -axis. On the other hand, a function

$$y(x, t) = a \sin(kx + \omega t + \phi) \quad (14.4)$$

represents a wave travelling in the negative direction of  $x$ -axis. Fig. (14.5) gives the names of the various physical quantities appearing in Eq. (14.2) that we now interpret.

$y(x, t)$	: displacement as a function of position $x$ and time $t$
$a$	: amplitude of a wave
$\omega$	: angular frequency of the wave
$k$	: angular wave number
$kx - \omega t + \phi$	: initial phase angle ( $a + x = 0, t = 0$ )

**Fig. 14.5** The meaning of standard symbols in Eq. (14.2)

Fig. 14.6 shows the plots of Eq. (14.2) for different values of time differing by equal intervals of time. In a wave, the crest is the point of maximum positive displacement, the trough is the point of maximum negative displacement. To see how a wave travels, we can fix attention on a crest and see how it progresses with time. In the figure, this is shown by a cross (  $\times$  ) on the crest. In the same manner, we can see the motion of a particular constituent of the medium at a fixed location, say at the origin of the  $x$ -axis. This is shown by a solid dot (  $\bullet$  ). The plots of Fig. 14.6 show that with time, the solid dot (  $\bullet$  ) at the origin moves periodically, i.e., the particle at the origin oscillates about its mean position as the wave progresses. This is true for any other location also. We also see that during the time the solid dot (  $\bullet$  ) has completed one full oscillation, the crest has moved further by a certain distance.

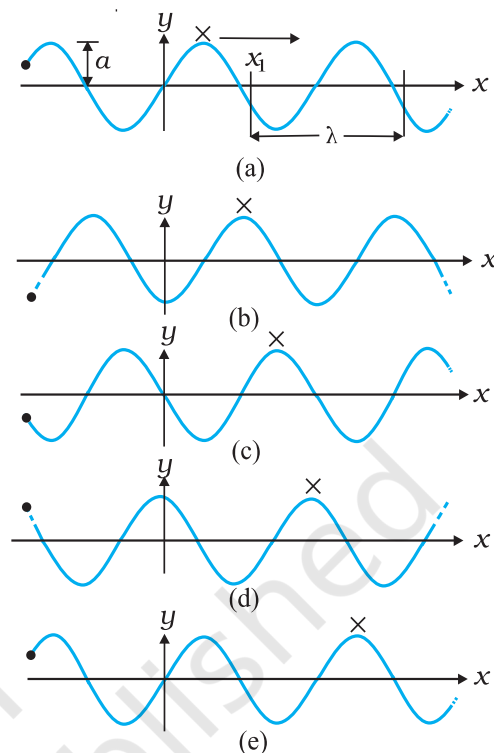

**Fig. 14.6** A harmonic wave progressing along the positive direction of  $x$ -axis at different times.

Using the plots of Fig. 14.6, we now define the various quantities of Eq. (14.2).

### 14.3.1 Amplitude and Phase

In Eq. (14.2), since the sine function varies between 1 and  $-1$ , the displacement  $y(x, t)$  varies between  $a$  and  $-a$ . We can take  $a$  to be a positive constant, without any loss of generality. Then,  $a$  represents the maximum displacement of the constituents of the medium from their equilibrium position. Note that the displacement  $y$  may be positive or negative, but  $a$  is positive. It is called the **amplitude** of the wave.

The quantity  $(kx - \omega t + \phi)$  appearing as the argument of the sine function in Eq. (14.2) is called the phase of the wave. Given the amplitude  $a$ , the phase determines the displacement of the wave at any position and at any instant. Clearly  $\phi$  is the phase at  $x = 0$  and  $t = 0$ . Hence,  $\phi$  is called the initial phase angle. By suitable choice of origin on the  $x$ -axis and the initial time, it is possible to have  $\phi = 0$ . Thus there is no loss of generality in dropping  $\phi$ , i.e., in taking Eq. (14.2) with  $\phi = 0$ .

### 14.3.2 Wavelength and Angular Wave Number

The minimum distance between two points having the same phase is called the wavelength of the wave, usually denoted by  $\lambda$ . For simplicity, we can choose points of the same phase to be crests or troughs. The wavelength is then the distance between two consecutive crests or troughs in a wave. Taking  $\phi = 0$  in Eq. (14.2), the displacement at  $t = 0$  is given by

$$y(x, 0) = a \sin kx \quad (14.5)$$

Since the sine function repeats its value after every  $2\pi$  change in angle,

$$\sin kx = \sin(kx + 2n\pi) = \sin k\left(x + \frac{2n\pi}{k}\right)$$

That is the displacements at points  $x$  and at

$$x + \frac{2n\pi}{k}$$

are the same, where  $n=1,2,3,\dots$ . The least distance between points with the same displacement (at any given instant of time) is obtained by taking  $n = 1$ .  $\lambda$  is then given by

$$\lambda = \frac{2\pi}{k} \quad \text{or} \quad k = \frac{2\pi}{\lambda} \quad (14.6)$$

$k$  is the angular wave number or propagation constant; its SI unit is radian per metre or  $\text{rad m}^{-1}$ \*

### 14.3.3 Period, Angular Frequency and Frequency

Fig. 14.7 shows again a sinusoidal plot. It describes not the shape of the wave at a certain instant but the displacement of an element (at any fixed location) of the medium as a function of time. We may for, simplicity, take Eq. (14.2) with  $\phi = 0$  and monitor the motion of the element say at  $x = 0$ . We then get

$$\begin{aligned} y(0, t) &= a \sin(-\omega t) \\ &= -a \sin \omega t \end{aligned}$$

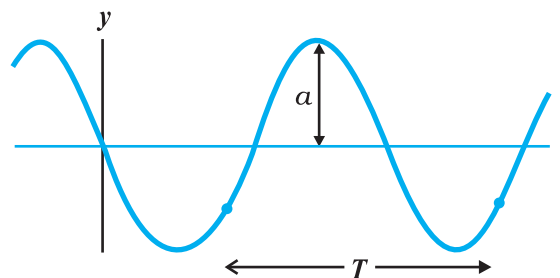

**Fig. 14.7** An element of a string at a fixed location oscillates in time with amplitude  $a$  and period  $T$ , as the wave passes over it.

Now, the period of oscillation of the wave is the time it takes for an element to complete one full oscillation. That is

$$\begin{aligned} -a \sin \omega t &= -a \sin \omega(t + T) \\ &= -a \sin(\omega t + \omega T) \end{aligned}$$

Since sine function repeats after every  $2\pi$ ,

$$\omega T = 2\pi \quad \text{or} \quad \omega = \frac{2\pi}{T} \quad (14.7)$$

$\omega$  is called the angular frequency of the wave. Its SI unit is  $\text{rad s}^{-1}$ . The frequency  $\nu$  is the number of oscillations per second. Therefore,

$$\nu = \frac{1}{T} = \frac{\omega}{2\pi} \quad (14.8)$$

$\nu$  is usually measured in hertz.

In the discussion above, reference has always been made to a wave travelling along a string or a transverse wave. In a longitudinal wave, the displacement of an element of the medium is parallel to the direction of propagation of the wave. In Eq. (14.2), the displacement function for a longitudinal wave is written as,

$$s(x, t) = a \sin(kx - \omega t + \phi) \quad (14.9)$$

where  $s(x, t)$  is the displacement of an element of the medium in the direction of propagation of the wave at position  $x$  and time  $t$ . In Eq. (14.9),  $a$  is the displacement amplitude; other quantities have the same meaning as in case of a transverse wave except that the displacement function  $y(x, t)$  is to be replaced by the function  $s(x, t)$ .

\* Here again, 'radian' could be dropped and the units could be written merely as  $\text{m}^{-1}$ . Thus,  $k$  represents  $2\pi$  times the number of waves (or the total phase difference) that can be accommodated per unit length, with SI units  $\text{m}^{-1}$ .

► **Example 14.2** A wave travelling along a string is described by,

$$y(x, t) = 0.005 \sin(80.0x - 3.0t),$$

in which the numerical constants are in SI units (0.005 m, 80.0 rad m<sup>-1</sup>, and 3.0 rad s<sup>-1</sup>). Calculate (a) the amplitude, (b) the wavelength, and (c) the period and frequency of the wave. Also, calculate the displacement  $y$  of the wave at a distance  $x = 30.0$  cm and time  $t = 20$  s?

**Answer** On comparing this displacement equation with Eq. (14.2),

$$y(x, t) = a \sin(kx - \omega t),$$

we find

- (a) the amplitude of the wave is 0.005 m = 5 mm.  
 (b) the angular wave number  $k$  and angular frequency  $\omega$  are

$$k = 80.0 \text{ m}^{-1} \text{ and } \omega = 3.0 \text{ s}^{-1}$$

We, then, relate the wavelength  $\lambda$  to  $k$  through Eq. (14.6),

$$\begin{aligned} \lambda &= 2\pi/k \\ &= \frac{2\pi}{80.0 \text{ m}^{-1}} \\ &= 7.85 \text{ cm} \end{aligned}$$

- (c) Now, we relate  $T$  to  $\omega$  by the relation

$$\begin{aligned} T &= 2\pi/\omega \\ &= \frac{2\pi}{3.0 \text{ s}^{-1}} \\ &= 2.09 \text{ s} \end{aligned}$$

and frequency,  $\nu = 1/T = 0.48$  Hz

The displacement  $y$  at  $x = 30.0$  cm and time  $t = 20$  s is given by

$$\begin{aligned} y &= (0.005 \text{ m}) \sin(80.0 \times 0.3 - 3.0 \times 20) \\ &= (0.005 \text{ m}) \sin(-36 + 12\pi) \\ &= (0.005 \text{ m}) \sin(1.699) \\ &= (0.005 \text{ m}) \sin(97^\circ) \approx 5 \text{ mm} \end{aligned}$$

#### 14.4 THE SPEED OF A TRAVELLING WAVE

To determine the speed of propagation of a travelling wave, we can fix our attention on any particular point on the wave (characterised by some value of the phase) and see how that point moves in time. It is convenient to look at the motion of the crest of the wave. Fig. 14.8 gives

the shape of the wave at two instants of time, which differ by a small time interval  $\Delta t$ . The entire wave pattern is seen to shift to the right (positive direction of  $x$ -axis) by a distance  $\Delta x$ . In particular, the crest shown by a dot (•) moves a

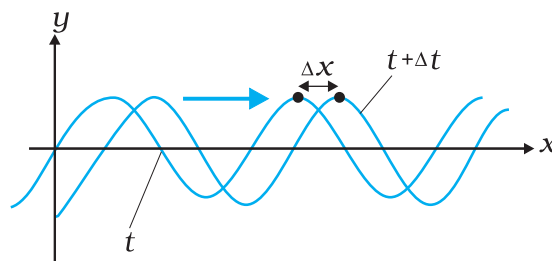

**Fig. 14.8** Progression of a harmonic wave from time  $t$  to  $t + \Delta t$ , where  $\Delta t$  is a small interval. The wave pattern as a whole shifts to the right. The crest of the wave (or a point with any fixed phase) moves right by the distance  $\Delta x$  in time  $\Delta t$ .

distance  $\Delta x$  in time  $\Delta t$ . The speed of the wave is then  $\Delta x/\Delta t$ . We can put the dot (•) on a point with any other phase. It will move with the same speed  $v$  (otherwise the wave pattern will not remain fixed). The motion of a fixed phase point on the wave is given by

$$kx - \omega t = \text{constant} \quad (14.10)$$

Thus, as time  $t$  changes, the position  $x$  of the fixed phase point must change so that the phase remains constant. Thus,

$$kx - \omega t = k(x + \Delta x) - \omega(t + \Delta t)$$

$$\text{or } k \Delta x - \omega \Delta t = 0$$

Taking  $\Delta x$ ,  $\Delta t$  vanishingly small, this gives

$$\frac{dx}{dt} = \frac{\omega}{k} = v \quad (14.11)$$

Relating  $\omega$  to  $T$  and  $k$  to  $\lambda$ , we get

$$v = \frac{2\pi\nu}{2\pi/\lambda} = \lambda\nu = \frac{\lambda}{T} \quad (14.12)$$

Eq. (14.12), a general relation for all progressive waves, shows that in the time required for one full oscillation by any constituent of the medium, the wave pattern travels a distance equal to the wavelength of the wave. It should be noted that the speed of a mechanical wave is determined by the inertial (linear mass density for strings, mass density in general) and elastic properties (Young's modulus for linear media/ shear modulus, bulk modulus) of the medium. The medium determines

the speed; Eq. (14.12) then relates wavelength to frequency for the given speed. Of course, as remarked earlier, the medium can support both transverse and longitudinal waves, which will have different speeds in the same medium. Later in this chapter, we shall obtain specific expressions for the speed of mechanical waves in some media.

#### 14.4.1 Speed of a Transverse Wave on Stretched String

The speed of a mechanical wave is determined by the restoring force setup in the medium when it is disturbed and the inertial properties (mass density) of the medium. The speed is expected to be directly related to the former and inversely to the latter. For waves on a string, the restoring force is provided by the tension  $T$  in the string. The inertial property will in this case be linear mass density  $\mu$ , which is mass  $m$  of the string divided by its length  $L$ . Using Newton's Laws of Motion, an exact formula for the wave speed on a string can be derived, but this derivation is outside the scope of this book. We shall, therefore, use dimensional analysis. We already know that dimensional analysis alone can never yield the exact formula. The overall dimensionless constant is always left undetermined by dimensional analysis.

The dimension of  $\mu$  is  $[ML^{-1}]$  and that of  $T$  is like force, namely  $[MLT^{-2}]$ . We need to combine these dimensions to get the dimension of speed  $v$   $[LT^{-1}]$ . Simple inspection shows that the quantity  $T/\mu$  has the relevant dimension

$$\frac{[MLT^{-2}]}{[ML]} = [L^2T^{-2}]$$

Thus if  $T$  and  $\mu$  are assumed to be the only relevant physical quantities,

$$v = C \sqrt{\frac{T}{\mu}} \quad (14.13)$$

where  $C$  is the undetermined constant of dimensional analysis. In the exact formula, it turns out,  $C=1$ . The speed of transverse waves on a stretched string is given by

$$v = \sqrt{\frac{T}{\mu}} \quad (14.14)$$

Note the important point that the speed  $v$  depends only on the properties of the medium  $T$  and  $\mu$  ( $T$  is a property of the stretched string

arising due to an external force). It does not depend on wavelength or frequency of the wave itself. In higher studies, you will come across waves whose speed is not independent of frequency of the wave. Of the two parameters  $\lambda$  and  $\nu$  the source of disturbance determines the frequency of the wave generated. Given the speed of the wave in the medium and the frequency Eq. (14.12) then fixes the wavelength

$$\lambda = \frac{v}{\nu} \quad (14.15)$$

► **Example 14.3** A steel wire 0.72 m long has a mass of  $5.0 \times 10^{-3}$  kg. If the wire is under a tension of 60 N, what is the speed of transverse waves on the wire ?

**Answer** Mass per unit length of the wire,

$$\mu = \frac{5.0 \times 10^{-3} \text{ kg}}{0.72 \text{ m}}$$

$$= 6.9 \times 10^{-3} \text{ kg m}^{-1}$$

Tension,  $T = 60 \text{ N}$

The speed of wave on the wire is given by

$$v = \sqrt{\frac{T}{\mu}} = \sqrt{\frac{60 \text{ N}}{6.9 \times 10^{-3} \text{ kg m}^{-1}}} = 93 \text{ m s}^{-1} \quad \blacktriangleleft$$

#### 14.4.2 Speed of a Longitudinal Wave (Speed of Sound)

In a longitudinal wave, the constituents of the medium oscillate forward and backward in the direction of propagation of the wave. We have already seen that the sound waves travel in the form of compressions and rarefactions of small volume elements of air. The elastic property that determines the stress under compressional strain is the bulk modulus of the medium defined by (see Chapter 8)

$$B = -\frac{\Delta P}{\Delta V/V} \quad (14.16)$$

Here, the change in pressure  $\Delta P$  produces a volumetric strain  $\frac{\Delta V}{V}$ .  $B$  has the same dimension as pressure and given in SI units in terms of pascal ( $Pa$ ). The inertial property relevant for the propagation of wave is the mass density  $\rho$ , with dimensions  $[ML^{-3}]$ . Simple inspection reveals that quantity  $B/\rho$  has the relevant dimension:

$$\frac{[ML^{-2}T^{-2}]}{[ML^{-3}]} = [L^2T^{-2}] \quad (14.17)$$

Thus, if  $B$  and  $\rho$  are considered to be the only relevant physical quantities,

$$v = C \sqrt{\frac{B}{\rho}} \quad (14.18)$$

where, as before,  $C$  is the undetermined constant from dimensional analysis. The exact derivation shows that  $C=1$ . Thus, the general formula for longitudinal waves in a medium is:

$$v = \sqrt{\frac{B}{\rho}} \quad (14.19)$$

For a linear medium, like a solid bar, the lateral expansion of the bar is negligible and we may consider it to be only under longitudinal strain. In that case, the relevant modulus of elasticity is Young's modulus, which has the same dimension as the Bulk modulus. Dimensional analysis for this case is the same as before and yields a relation like Eq. (14.18), with an undetermined  $C$ , which the exact derivation shows to be unity. Thus, the speed of longitudinal waves in a solid bar is given by

$$v = \sqrt{\frac{Y}{\rho}} \quad (14.20)$$

where  $Y$  is the Young's modulus of the material of the bar. Table 14.1 gives the speed of sound in some media.

**Table 14.1 Speed of Sound in some Media**

Medium	Speed (m s <sup>-1</sup> )
<b>Gases</b>	
Air (0 °C)	331
Air (20 °C)	343
Helium	965
Hydrogen	1284
<b>Liquids</b>	
Water (0 °C)	1402
Water (20 °C)	1482
Seawater	1522
<b>Solids</b>	
Aluminium	6420
Copper	3560
Steel	5941
Granite	6000
Vulcanised Rubber	54

Liquids and solids generally have higher speed of sound than gases. [Note for solids, the speed being referred to is the speed of longitudinal waves in the solid]. This happens because they are much more difficult to compress than gases and so have much higher values of bulk modulus. Now, see Eq. (14.19). Solids and liquids have higher mass densities ( $\rho$ ) than gases. But the corresponding increase in both the modulus ( $B$ ) of solids and liquids is much higher. This is the reason why the sound waves travel faster in solids and liquids.

We can estimate the speed of sound in a gas in the ideal gas approximation. For an ideal gas, the pressure  $P$ , volume  $V$  and temperature  $T$  are related by (see Chapter 10).

$$PV = Nk_B T \quad (14.21)$$

where  $N$  is the number of molecules in volume  $V$ ,  $k_B$  is the Boltzmann constant and  $T$  the temperature of the gas (in Kelvin). Therefore, for an isothermal change it follows from Eq.(14.21) that

$$V\Delta P + P\Delta V = 0$$

$$\text{or } -\frac{\Delta P}{\Delta V/V} = P$$

Hence, substituting in Eq. (14.16), we have

$$B = P$$

Therefore, from Eq. (14.19) the speed of a longitudinal wave in an ideal gas is given by,

$$v = \sqrt{\frac{P}{\rho}} \quad (14.22)$$

This relation was first given by Newton and is known as Newton's formula.

► **Example 14.4** Estimate the speed of sound in air at standard temperature and pressure. The mass of 1 mole of air is  $29.0 \times 10^{-3}$  kg.

**Answer** We know that 1 mole of any gas occupies 22.4 litres at STP. Therefore, density of air at STP is:

$$\rho_o = (\text{mass of one mole of air}) / (\text{volume of one mole of air at STP})$$

$$\begin{aligned} &= \frac{29.0 \times 10^{-3} \text{ kg}}{22.4 \times 10^{-3} \text{ m}^3} \\ &= 1.29 \text{ kg m}^{-3} \end{aligned}$$

According to Newton's formula for the speed of sound in a medium, we get for the speed of sound in air at STP,

$$v = \left[ \frac{1.01 \times 10^5 \text{ N m}^{-2}}{1.29 \text{ kg m}^{-3}} \right]^{1/2} = 280 \text{ m s}^{-1} \quad (14.23)$$

The result shown in Eq.(14.23) is about 15% smaller as compared to the experimental value of  $331 \text{ m s}^{-1}$  as given in Table 14.1. Where did we go wrong? If we examine the basic assumption made by Newton that the pressure variations in a medium during propagation of sound are isothermal, we find that this is not correct. It was pointed out by Laplace that the pressure variations in the propagation of sound waves are so fast that there is little time for the heat flow to maintain constant temperature. These variations, therefore, are adiabatic and not isothermal. For adiabatic processes the ideal gas satisfies the relation (see Section 11.8),

$$PV^\gamma = \text{constant}$$

i.e.  $\Delta(PV^\gamma) = 0$

or  $P\gamma V^{\gamma-1} \Delta V + V^\gamma \Delta P = 0$

where  $\gamma$  is the ratio of two specific heats,  $C_p/C_v$ .

Thus, for an ideal gas the adiabatic bulk modulus is given by,

$$B_{ad} = -\frac{\Delta P}{\Delta V/V} = \gamma P$$

The speed of sound is, therefore, from Eq. (14.19), given by,

$$v = \sqrt{\frac{\gamma P}{\rho}} \quad (14.24)$$

This modification of Newton's formula is referred to as the **Laplace correction**. For air  $\gamma = 7/5$ . Now using Eq. (14.24) to estimate the speed of sound in air at STP, we get a value  $331.3 \text{ m s}^{-1}$ , which agrees with the measured speed.

#### 14.5 THE PRINCIPLE OF SUPERPOSITION OF WAVES

What happens when two wave pulses travelling in opposite directions cross each other (Fig. 14.9)? It turns out that wave pulses continue to retain their identities after they have crossed. However, during the time they overlap, the wave pattern is different from either of the

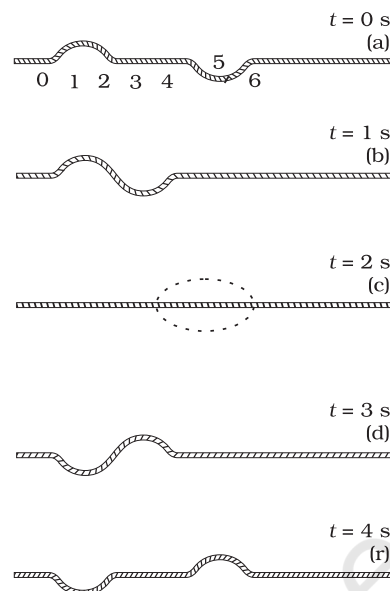

**Fig. 14.9** Two pulses having equal and opposite displacements moving in opposite directions. The overlapping pulses add up to zero displacement in curve (c).

pulses. Figure 14.9 shows the situation when two pulses of equal and opposite shapes move towards each other. When the pulses overlap, the resultant displacement is the algebraic sum of the displacement due to each pulse. This is known as the principle of superposition of waves. According to this principle, each pulse moves as if others are not present. The constituents of the medium, therefore, suffer displacements due to both and since the displacements can be positive and negative, the net displacement is an algebraic sum of the two. Fig. 14.9 gives graphs of the wave shape at different times. Note the dramatic effect in the graph (c); the displacements due to the two pulses have exactly cancelled each other and there is zero displacement throughout.

To put the principle of superposition mathematically, let  $y_1(x, t)$  and  $y_2(x, t)$  be the displacements due to two wave disturbances in the medium. If the waves arrive in a region simultaneously, and therefore, overlap, the net displacement  $y(x, t)$  is given by

$$y(x, t) = y_1(x, t) + y_2(x, t) \quad (14.25)$$

If we have two or more waves moving in the medium the resultant waveform is the sum of wave functions of individual waves. That is, if the wave functions of the moving waves are



$$\begin{aligned}
 y_1 &= f_1(x-vt), \\
 y_2 &= f_2(x-vt), \\
 &\dots\dots\dots \\
 &\dots\dots\dots \\
 y_n &= f_n(x-vt)
 \end{aligned}$$

then the wave function describing the disturbance in the medium is

$$\begin{aligned}
 y &= f_1(x-vt) + f_2(x-vt) + \dots + f_n(x-vt) \\
 &= \sum_{i=1}^n f_i(x-vt) \quad (14.26)
 \end{aligned}$$

The principle of superposition is basic to the phenomenon of interference.

For simplicity, consider two harmonic travelling waves on a stretched string, both with the same  $\omega$  (angular frequency) and  $k$  (wave number), and, therefore, the same wavelength  $\lambda$ . Their wave speed will be identical. Let us further assume that their amplitudes are equal and they are both travelling in the positive direction of  $x$ -axis. The waves only differ in their initial phase. According to Eq. (14.2), the two waves are described by the functions:

$$y_1(x, t) = a \sin(kx - \omega t) \quad (14.27)$$

$$\text{and } y_2(x, t) = a \sin(kx - \omega t + \phi) \quad (14.28)$$

The net displacement is then, by the principle of superposition, given by

$$y(x, t) = a \sin(kx - \omega t) + a \sin(kx - \omega t + \phi) \quad (14.29)$$

$$= a \left[ 2 \sin \left[ \frac{(kx - \omega t) + (kx - \omega t + \phi)}{2} \right] \cos \frac{\phi}{2} \right] \quad (14.30)$$

where we have used the familiar trigonometric identity for  $\sin A + \sin B$ . We then have

$$y(x, t) = 2a \cos \frac{\phi}{2} \sin \left( kx - \omega t + \frac{\phi}{2} \right) \quad (14.31)$$

Eq. (14.31) is also a harmonic travelling wave in the positive direction of  $x$ -axis, with the same frequency and wavelength. However, its initial phase angle is  $\frac{\phi}{2}$ . The significant thing is that its amplitude is a function of the phase difference

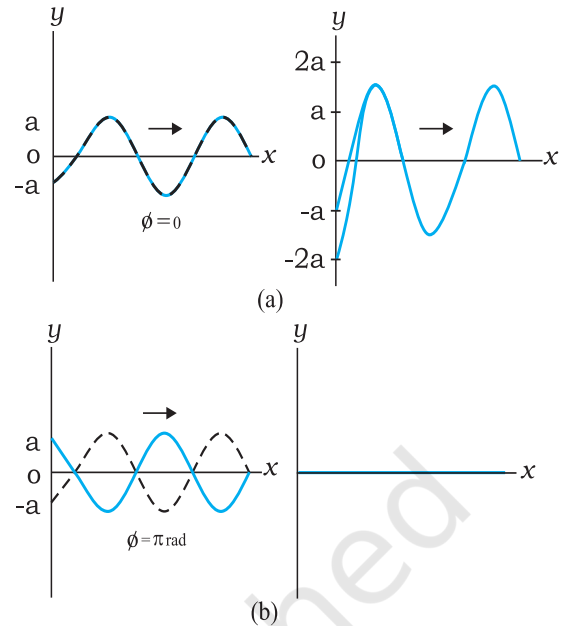

**Fig. 14.10** The resultant of two harmonic waves of equal amplitude and wavelength according to the principle of superposition. The amplitude of the resultant wave depends on the phase difference  $\phi$ , which is zero for (a) and  $\pi$  for (b)

$\phi$  between the constituent two waves:

$$A(\phi) = 2a \cos \frac{1}{2}\phi \quad (14.32)$$

For  $\phi = 0$ , when the waves are in phase,

$$y(x, t) = 2a \sin(kx - \omega t) \quad (14.33)$$

i.e., the resultant wave has amplitude  $2a$ , the largest possible value for  $A$ . For  $\phi = \pi$ , the waves are completely, out of phase and the resultant wave has zero displacement everywhere at all times

$$y(x, t) = 0 \quad (14.34)$$

Eq. (14.33) refers to the so-called constructive interference of the two waves where the amplitudes add up in the resultant wave. Eq. (14.34) is the case of destructive interference where the amplitudes subtract out in the resultant wave. Fig. 14.10 shows these two cases of interference of waves arising from the principle of superposition.

## 14.6 REFLECTION OF WAVES

So far we considered waves propagating in an unbounded medium. What happens if a pulse or a wave meets a boundary? If the boundary is rigid, the pulse or wave gets reflected. The

phenomenon of echo is an example of reflection by a rigid boundary. If the boundary is not completely rigid or is an interface between two different elastic media, the situation is somewhat complicated. A part of the incident wave is reflected and a part is transmitted into the second medium. If a wave is incident obliquely on the boundary between two different media the transmitted wave is called the **refracted wave**. The incident and refracted waves obey Snell's law of refraction, and the incident and reflected waves obey the usual laws of reflection.

Fig. 14.11 shows a pulse travelling along a stretched string and being reflected by the boundary. Assuming there is no absorption of energy by the boundary, the reflected wave has the same shape as the incident pulse but it suffers a phase change of  $\pi$  or  $180^\circ$  on reflection. This is because the boundary is rigid and the disturbance must have zero displacement at all times at the boundary. By the principle of superposition, this is possible only if the reflected and incident waves differ by a phase of  $\pi$ , so that the resultant displacement is zero. This reasoning is based on boundary condition on a rigid wall. We can arrive at the same conclusion dynamically also. As the pulse arrives at the wall, it exerts a force on the wall. By Newton's Third Law, the wall exerts an equal and opposite force on the string generating a reflected pulse that differs by a phase of  $\pi$ .

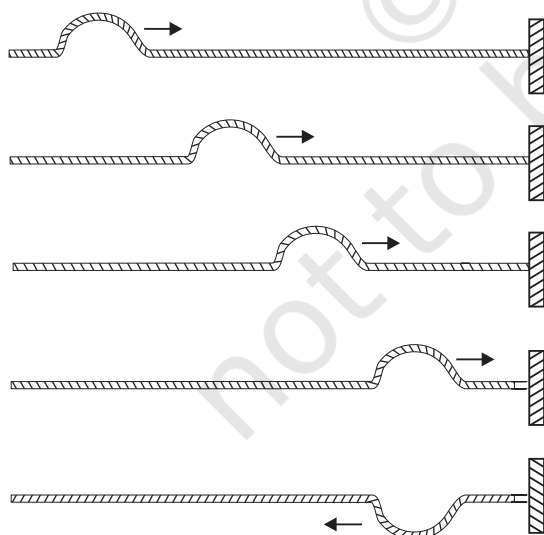

**Fig. 14.11** Reflection of a pulse meeting a rigid boundary.

If on the other hand, the boundary point is not rigid but completely free to move (such as in the case of a string tied to a freely moving ring on a rod), the reflected pulse has the same phase and amplitude (assuming no energy dissipation) as the incident pulse. The net maximum displacement at the boundary is then twice the amplitude of each pulse. An example of non-rigid boundary is the open end of an organ pipe.

To summarise, a travelling wave or pulse suffers a phase change of  $\pi$  on reflection at a rigid boundary and no phase change on reflection at an open boundary. To put this mathematically, let the incident travelling wave be

$$y_2(x, t) = a \sin(kx - \omega t)$$

At a rigid boundary, the reflected wave is given by

$$\begin{aligned} y_r(x, t) &= a \sin(kx - \omega t + \pi) \\ &= -a \sin(kx - \omega t) \end{aligned} \quad (14.35)$$

At an open boundary, the reflected wave is given by

$$\begin{aligned} y_r(x, t) &= a \sin(kx - \omega t + 0) \\ &= a \sin(kx - \omega t) \end{aligned} \quad (14.36)$$

Clearly, at the rigid boundary,  $y = y_2 + y_r = 0$  at all times.

#### 14.6.1 Standing Waves and Normal Modes

We considered above reflection at one boundary. But there are familiar situations (a string fixed at either end or an air column in a pipe with either end closed) in which reflection takes place at two or more boundaries. In a string, for example, a wave travelling in one direction will get reflected at one end, which in turn will travel and get reflected from the other end. This will go on until there is a steady wave pattern set up on the string. Such wave patterns are called standing waves or stationary waves. To see this mathematically, consider a wave travelling along the positive direction of  $x$ -axis and a reflected wave of the same amplitude and wavelength in the negative direction of  $x$ -axis. From Eqs. (14.2) and (14.4), with  $\phi = 0$ , we get:

$$y_1(x, t) = a \sin(kx - \omega t)$$

$$y_2(x, t) = a \sin(kx + \omega t)$$

The resultant wave on the string is, according to the principle of superposition:

$$y(x, t) = y_1(x, t) + y_2(x, t)$$

$$= a [\sin (kx - \omega t) + \sin (kx + \omega t)]$$

Using the familiar trigonometric identity  $\sin (A+B) + \sin (A-B) = 2 \sin A \cos B$  we get,

$$y(x, t) = 2a \sin kx \cos \omega t \quad (14.37)$$

Note the important difference in the wave pattern described by Eq. (14.37) from that described by Eq. (14.2) or Eq. (14.4). The terms  $kx$  and  $\omega t$  appear separately, not in the combination  $kx - \omega t$ . The amplitude of this wave is  $2a \sin kx$ . Thus, in this wave pattern, the amplitude varies from point-to-point, but each element of the string oscillates with the same angular frequency  $\omega$  or time period. There is no phase difference between oscillations of different elements of the wave. The string as a whole vibrates in phase with differing amplitudes at different points. The wave pattern is neither moving to the right nor to the left. Hence, they are called standing or stationary waves. The amplitude is fixed at a given location but, as remarked earlier, it is different at different locations. The points at which the amplitude is zero (i.e., where there is no motion at all) are

**nodes**; the points at which the amplitude is the largest are called **antinodes**. Fig. 14.12 shows a stationary wave pattern resulting from superposition of two travelling waves in opposite directions.

The most significant feature of stationary waves is that the boundary conditions constrain the possible wavelengths or frequencies of vibration of the system. The system cannot oscillate with any arbitrary frequency (contrast this with a harmonic travelling wave), but is characterised by a set of natural frequencies or **normal modes** of oscillation. Let us determine these normal modes for a stretched string fixed at both ends.

First, from Eq. (14.37), the positions of nodes (where the amplitude is zero) are given by  $\sin kx = 0$ .

which implies

$$kx = n\pi; \quad n = 0, 1, 2, 3, \dots$$

Since,  $k = 2\pi/\lambda$ , we get

$$x = \frac{n\lambda}{2}; \quad n = 0, 1, 2, 3, \dots \quad (14.38)$$

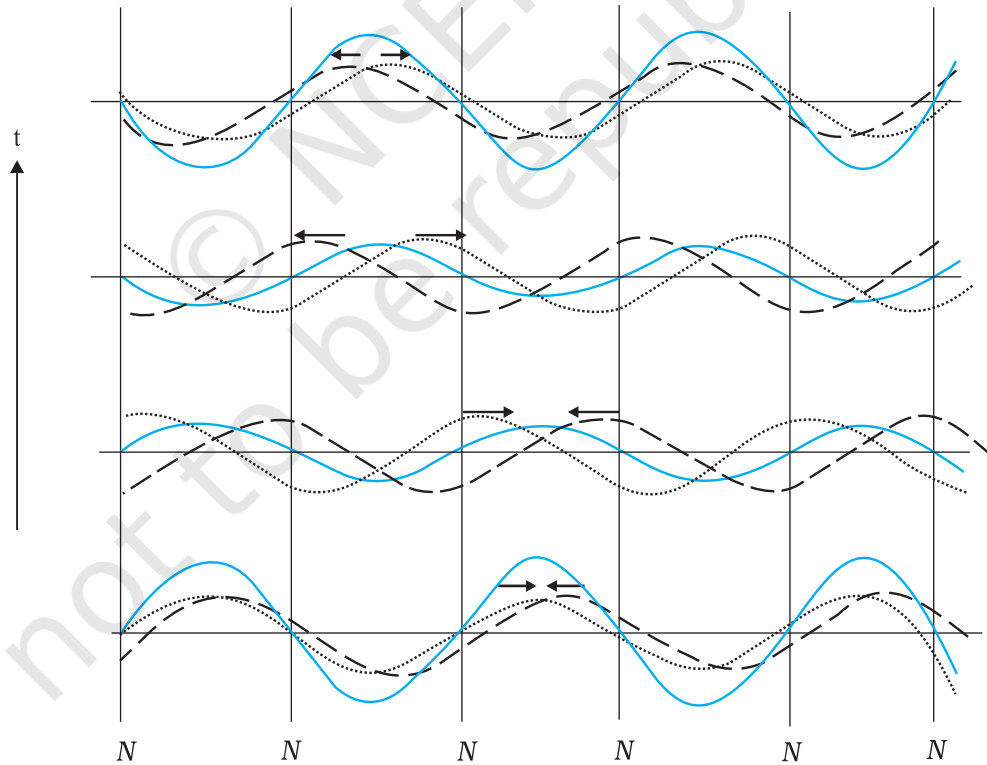

**Fig. 14.12** Stationary waves arising from superposition of two harmonic waves travelling in opposite directions. Note that the positions of zero displacement (nodes) remain fixed at all times.

Clearly, the distance between any two successive nodes is  $\frac{\lambda}{2}$ . In the same way, the positions of antinodes (where the amplitude is the largest) are given by the largest value of  $\sin kx$ :

$$|\sin kx| = 1$$

which implies

$$kx = (n + \frac{1}{2})\pi; n = 0, 1, 2, 3, \dots$$

With  $k = 2\pi/\lambda$ , we get

$$x = (n + \frac{1}{2})\frac{\lambda}{2}; n = 0, 1, 2, 3, \dots \quad (14.39)$$

Again the distance between any two consecutive antinodes is  $\frac{\lambda}{2}$ . Eq. (14.38) can be applied to

the case of a stretched string of length  $L$  fixed at both ends. Taking one end to be at  $x = 0$ , the boundary conditions are that  $x = 0$  and  $x = L$  are positions of nodes. The  $x = 0$  condition is already satisfied. The  $x = L$  node condition requires that the length  $L$  is related to  $\lambda$  by

$$L = n \frac{\lambda}{2}; n = 1, 2, 3, \dots \quad (14.40)$$

Thus, the possible wavelengths of stationary waves are constrained by the relation

$$\lambda = \frac{2L}{n}; n = 1, 2, 3, \dots \quad (14.41)$$

with corresponding frequencies

$$v = \frac{nv}{2L}, \text{ for } n = 1, 2, 3, \dots \quad (14.42)$$

We have thus obtained the natural frequencies - the normal modes of oscillation of the system. The lowest possible natural frequency of a system is called its **fundamental mode** or the **first harmonic**. For the stretched string fixed at either end

it is given by  $v = \frac{v}{2L}$ , corresponding

to  $n = 1$  of Eq. (14.42). Here  $v$  is the

speed of wave determined by the properties of the medium. The  $n = 2$  frequency is called the second harmonic;  $n = 3$  is the third harmonic and so on. We can label the various harmonics by the symbol  $v_n$  ( $n = 1, 2, \dots$ ).

Fig. 14.13 shows the first six harmonics of a stretched string fixed at either end. A string need not vibrate in one of these modes only. Generally, the vibration of a string will be a superposition of different modes; some modes may be more strongly excited and some less. Musical instruments like sitar or violin are based on this principle. Where the string is plucked or bowed, determines which modes are more prominent than others.

Let us next consider normal modes of oscillation of an air column with one end closed

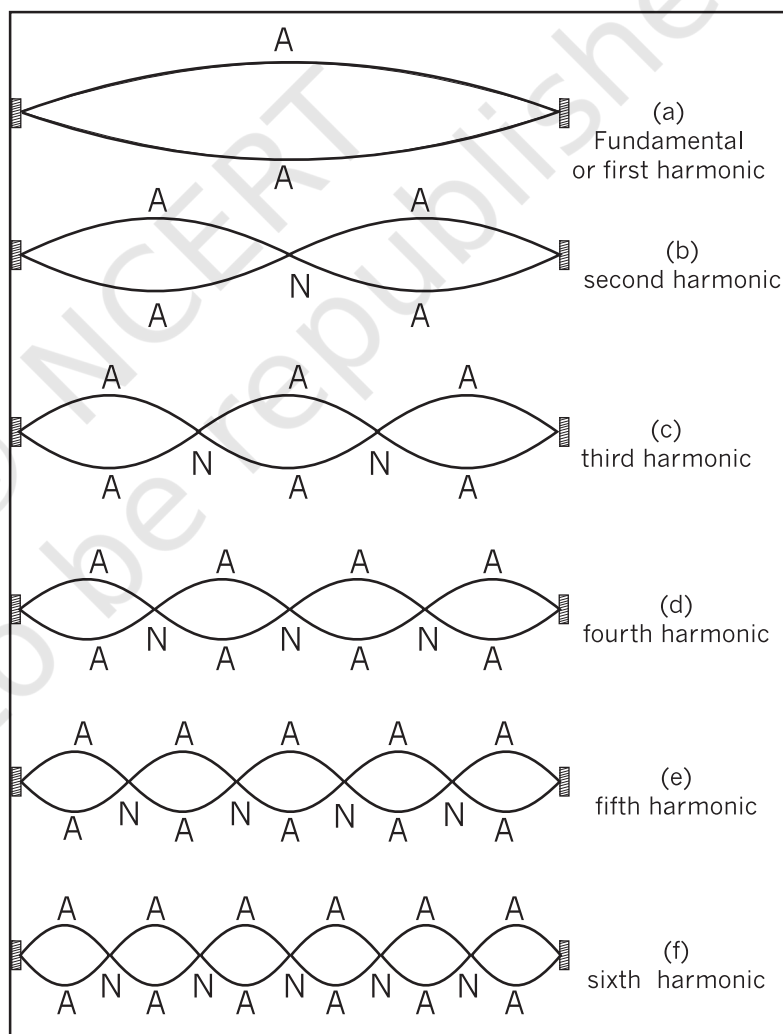

**Fig. 14.13** The first six harmonics of vibrations of a stretched string fixed at both ends.

and the other open. A glass tube partially filled with water illustrates this system. The end in contact with water is a node, while the open end is an antinode. At the node the pressure changes are the largest, while the displacement is minimum (zero). At the open end - the antinode, it is just the other way - least pressure change and maximum amplitude of displacement. Taking the end in contact with water to be  $x = 0$ , the node condition (Eq. 14.38) is already satisfied. If the other end  $x = L$  is an antinode, Eq. (14.39) gives

$$L = \left(n + \frac{1}{2}\right) \frac{\lambda}{2}, \text{ for } n = 0, 1, 2, 3, \dots$$

The possible wavelengths are then restricted by the relation :

$$\lambda = \frac{2L}{\left(n + \frac{1}{2}\right)}, \text{ for } n = 0, 1, 2, 3, \dots \quad (14.43)$$

The normal modes - the natural frequencies - of the system are

$$v = \left(n + \frac{1}{2}\right) \frac{v}{2L}; n = 0, 1, 2, 3, \dots \quad (14.44)$$

The fundamental frequency corresponds to  $n = 0$ ,

and is given by  $\frac{v}{4L}$ . The higher frequencies are **odd harmonics**, i.e., odd multiples of the

fundamental frequency :  $3\frac{v}{4L}, 5\frac{v}{4L}$ , etc.

Fig. 14.14 shows the first six odd harmonics of air column with one end closed and the other open. For a pipe open at both ends, each end is an antinode. It is then easily seen that an open air column at both ends generates all harmonics (See Fig. 14.15).

The systems above, strings and air columns, can also undergo forced oscillations (Chapter 13). If the external frequency is close to one of the natural frequencies, the system shows **resonance**.

Normal modes of a circular membrane rigidly clamped to the circumference as in a tabla are determined by the boundary condition that no point on the circumference of the membrane vibrates. Estimation of the frequencies of normal

modes of this system is more complex. This problem involves wave propagation in two dimensions. However, the underlying physics is the same.

**Example 14.5** A pipe, 30.0 cm long, is open at both ends. Which harmonic mode of the pipe resonates a 1.1 kHz source? Will resonance with the same source be observed if one end of the pipe is closed? Take the speed of sound in air as  $330 \text{ m s}^{-1}$ .

**Answer** The first harmonic frequency is given by

$$v_1 = \frac{v}{\lambda_1} = \frac{v}{2L} \quad (\text{open pipe})$$

where  $L$  is the length of the pipe. The frequency of its  $n$ th harmonic is:

$$v_n = \frac{nv}{2L}, \text{ for } n = 1, 2, 3, \dots (\text{open pipe})$$

First few modes of an open pipe are shown in Fig. 14.15.

For  $L = 30.0 \text{ cm}$ ,  $v = 330 \text{ m s}^{-1}$ ,

$$v_n = \frac{n \cdot 330 \text{ (m s}^{-1}\text{)}}{0.6 \text{ (m)}} = 550 n \text{ s}^{-1}$$

Clearly, a source of frequency 1.1 kHz will resonate at  $v_2$ , i.e. the **second harmonic**.

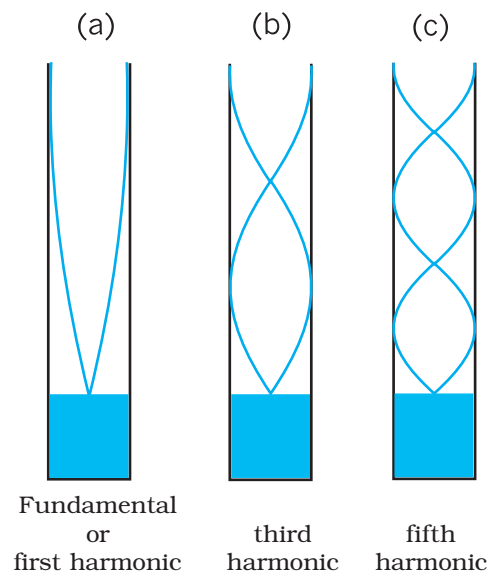

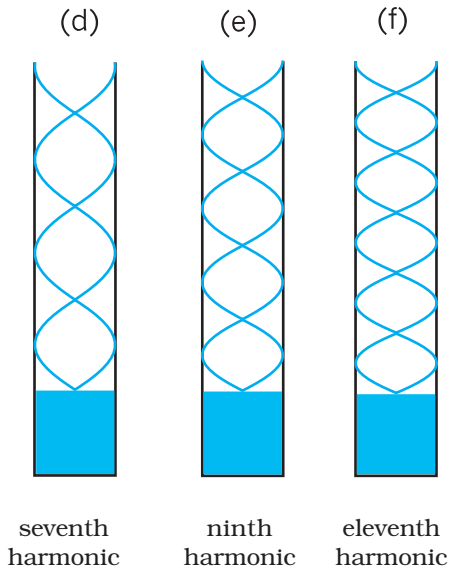

**Fig. 14.14** Normal modes of an air column open at one end and closed at the other. Only the odd harmonics are seen to be possible.

Now if one end of the pipe is closed (Fig. 14.15), it follows from Eq. (14.15) that the fundamental frequency is

$$v_1 = \frac{v}{\lambda_1} = \frac{v}{4L} \text{ (pipe closed at one end)}$$

and only the odd numbered harmonics are present :

$$v_3 = \frac{3v}{4L}, \quad v_5 = \frac{5v}{4L}, \text{ and so on.}$$

For  $L = 30 \text{ cm}$  and  $v = 330 \text{ m s}^{-1}$ , the fundamental frequency of the pipe closed at one end is 275 Hz and the source frequency corresponds to its fourth harmonic. Since this harmonic is not a possible mode, no resonance will be observed with the source, the moment one end is closed. ◀

### 14.7 BEATS

'Beats' is an interesting phenomenon arising from interference of waves. When two harmonic sound waves of close (but not equal) frequencies are heard at the same time, we hear a sound of similar frequency (the average of two close frequencies), but we hear something else also. We hear audibly distinct waxing and waning of the intensity of the sound, with a frequency equal to the difference in the two close frequencies. Artists use this phenomenon often

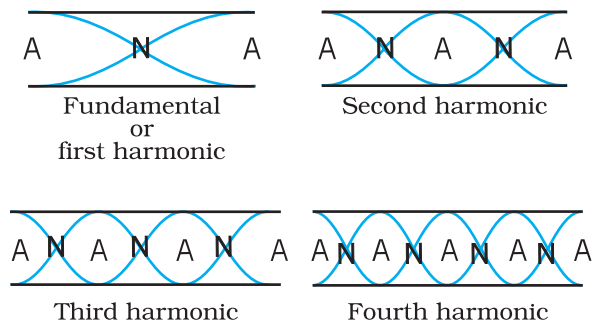

**Fig. 14.15** Standing waves in an open pipe, first four harmonics are depicted.

while tuning their instruments with each other. They go on tuning until their sensitive ears do not detect any beats.

To see this mathematically, let us consider two harmonic sound waves of nearly equal angular frequency  $\omega_1$  and  $\omega_2$  and fix the location to be  $x = 0$  for convenience. Eq. (14.2) with a suitable choice of phase ( $\phi = \pi/2$  for each) and, assuming equal amplitudes, gives

$$s_1 = a \cos \omega_1 t \text{ and } s_2 = a \cos \omega_2 t \quad (14.45)$$

Here we have replaced the symbol  $y$  by  $s$ , since we are referring to longitudinal not transverse displacement. Let  $\omega_1$  be the (slightly) greater of the two frequencies. The resultant displacement is, by the principle of superposition,

$$s = s_1 + s_2 = a (\cos \omega_1 t + \cos \omega_2 t)$$

Using the familiar trigonometric identity for  $\cos A + \cos B$ , we get

$$= 2 a \cos \frac{(\omega_1 - \omega_2)t}{2} \cos \frac{(\omega_1 + \omega_2)t}{2} \quad (14.46)$$

which may be written as :

$$s = [2 a \cos \omega_b t] \cos \omega_a t \quad (14.47)$$

If  $|\omega_1 - \omega_2| \ll \omega_1, \omega_2, \omega_a \gg \omega_b$ , then where

$$\omega_b = \frac{(\omega_1 - \omega_2)}{2} \text{ and } \omega_a = \frac{(\omega_1 + \omega_2)}{2}$$

Now if we assume  $|\omega_1 - \omega_2| \ll \omega_1$ , which means  $\omega_a \gg \omega_b$ , we can interpret Eq. (14.47) as follows. The resultant wave is oscillating with the average angular frequency  $\omega_a$ ; however its amplitude is **not** constant in time, unlike a pure harmonic wave. The amplitude is the largest when the term  $\cos \omega_b t$  takes its limit  $+1$  or  $-1$ . In other words, the intensity of the resultant wave waxes and wanes with a frequency which is  $2\omega_b = \omega_1 -$



### Musical Pillars

Temples often have some pillars portraying human figures playing musical instruments, but seldom do these pillars themselves produce music. At the Nelliappar temple in Tamil Nadu, gentle taps on a cluster of pillars carved out of a single piece of rock produce the basic notes of Indian classical music, viz. Sa, Re, Ga, Ma, Pa, Dha, Ni, Sa. Vibrations of these pillars depend on elasticity of the stone used, its density and shape.

Musical pillars are categorised into three types: The first is called the **Shruti Pillar**, as it can produce the basic notes — the “swaras”. The second type is the **Gana Thoongal**, which generates the basic tunes that make up the “ragas”. The third variety is the **Laya Thoongal** pillars that produce “taal” (beats) when tapped. The pillars at the Nelliappar temple are a combination of the Shruti and Laya types.

Archaeologists date the Nelliappar temple to the 7th century and claim it was built by successive rulers of the Pandyan dynasty.

The musical pillars of Nelliappar and several other temples in southern India like those at Hampi (picture), Kanyakumari, and Thiruvananthapuram are unique to the country and have no parallel in any other part of the world.

$\omega_2$ . Since  $\omega = 2\pi\nu$ , the beat frequency  $\nu_{beat}$  is given by

$$\nu_{beat} = \nu_1 - \nu_2 \quad (14.48)$$

Fig. 14.16 illustrates the phenomenon of beats for two harmonic waves of frequencies 11 Hz and 9 Hz. The amplitude of the resultant wave shows beats at a frequency of 2 Hz.

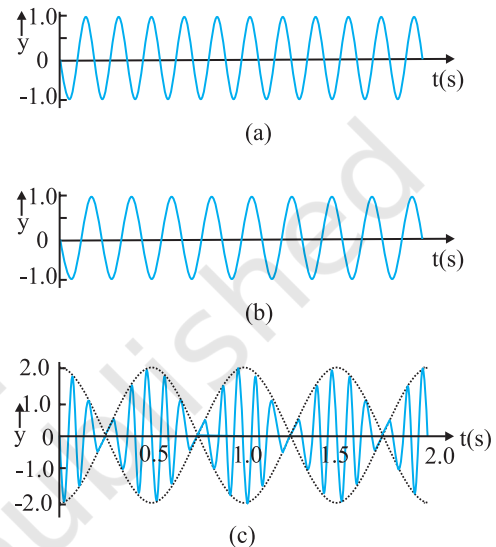

**Fig. 14.16** Superposition of two harmonic waves, one of frequency 11 Hz (a), and the other of frequency 9 Hz (b), giving rise to beats of frequency 2 Hz, as shown in (c).

► **Example 14.6** Two sitar strings A and B playing the note ‘Dha’ are slightly out of tune and produce beats of frequency 5 Hz. The tension of the string B is slightly increased and the beat frequency is found to decrease to 3 Hz. What is the original frequency of B if the frequency of A is 427 Hz ?

**Answer** Increase in the tension of a string increases its frequency. If the original frequency of B ( $\nu_B$ ) were greater than that of A ( $\nu_A$ ), further increase in  $\nu_B$  should have resulted in an increase in the beat frequency. But the beat frequency is found to decrease. This shows that  $\nu_B < \nu_A$ . Since  $\nu_A - \nu_B = 5$  Hz, and  $\nu_A = 427$  Hz, we get  $\nu_B = 422$  Hz. ◀

## SUMMARY

1. *Mechanical waves* can exist in material media and are governed by Newton's Laws.
2. *Transverse waves* are waves in which the particles of the medium oscillate perpendicular to the direction of wave propagation.
3. *Longitudinal waves* are waves in which the particles of the medium oscillate along the direction of wave propagation.
4. *Progressive wave* is a wave that moves from one point of medium to another.
5. *The displacement* in a sinusoidal wave propagating in the positive  $x$  direction is given by

$$y(x, t) = a \sin(kx - \omega t + \phi)$$

where  $a$  is the amplitude of the wave,  $k$  is the angular wave number,  $\omega$  is the angular frequency,  $(kx - \omega t + \phi)$  is the phase, and  $\phi$  is the phase constant or phase angle.

6. *Wavelength*  $\lambda$  of a progressive wave is the distance between two consecutive points of the same phase at a given time. In a stationary wave, it is twice the distance between two consecutive nodes or antinodes.
7. *Period*  $T$  of oscillation of a wave is defined as the time any element of the medium takes to move through one complete oscillation. It is related to the *angular frequency*  $\omega$  through the relation

$$T = \frac{2\pi}{\omega}$$

8. *Frequency*  $\nu$  of a wave is defined as  $1/T$  and is related to angular frequency by

$$\nu = \frac{\omega}{2\pi}$$

9. *Speed* of a progressive wave is given by  $v = \frac{\omega}{k} = \frac{\lambda}{T} = \lambda\nu$

10. *The speed of a transverse wave* on a stretched string is set by the properties of the string. The speed on a string with tension  $T$  and linear mass density  $\mu$  is

$$v = \sqrt{\frac{T}{\mu}}$$

11. *Sound waves* are longitudinal mechanical waves that can travel through solids, liquids, or gases. The speed  $v$  of sound wave in a fluid having *bulk modulus*  $B$  and density  $\rho$  is

$$v = \sqrt{\frac{B}{\rho}}$$

The speed of longitudinal waves in a metallic bar is

$$v = \sqrt{\frac{Y}{\rho}}$$

For gases, since  $B = \gamma P$ , the speed of sound is

$$v = \sqrt{\frac{\gamma P}{\rho}}$$



12. When two or more waves traverse simultaneously in the same medium, the displacement of any element of the medium is the algebraic sum of the displacements due to each wave. This is known as the *principle of superposition of waves*

$$y = \sum_{i=1}^n f_i(x - vt)$$

13. Two sinusoidal waves on the same string exhibit *interference*, adding or cancelling according to the principle of superposition. If the two are travelling in the same direction and have the same amplitude  $a$  and frequency but differ in phase by a *phase constant*  $\phi$ , the result is a single wave with the same frequency  $\omega$ :

$$y(x, t) = \left[ 2a \cos \frac{1}{2} \phi \right] \sin \left( kx - \omega t + \frac{1}{2} \phi \right)$$

If  $\phi = 0$  or an integral multiple of  $2\pi$ , the waves are exactly in phase and the interference is constructive; if  $\phi = \pi$ , they are exactly out of phase and the interference is destructive.

14. A travelling wave, at a rigid boundary or a closed end, is reflected with a phase reversal but the reflection at an open boundary takes place without any phase change.

For an incident wave

$$y_i(x, t) = a \sin(kx - \omega t)$$

the reflected wave at a rigid boundary is

$$y_r(x, t) = -a \sin(kx + \omega t)$$

For reflection at an open boundary

$$y_r(x, t) = a \sin(kx + \omega t)$$

15. The interference of two identical waves moving in opposite directions produces *standing waves*. For a string with fixed ends, the standing wave is given by

$$y(x, t) = [2a \sin kx] \cos \omega t$$

Standing waves are characterised by fixed locations of zero displacement called *nodes* and fixed locations of maximum displacements called *antinodes*. The separation between two consecutive nodes or antinodes is  $\lambda/2$ .

A stretched string of length  $L$  fixed at both the ends vibrates with frequencies given by

$$v = \frac{nv}{2L}, \quad n = 1, 2, 3, \dots$$

The set of frequencies given by the above relation are called the *normal modes* of oscillation of the system. The oscillation mode with lowest frequency is called the *fundamental mode* or the *first harmonic*. The *second harmonic* is the oscillation mode with  $n = 2$  and so on.

A pipe of length  $L$  with one end closed and other end open (such as air columns) vibrates with frequencies given by

$$v = (n + \frac{1}{2}) \frac{v}{2L}, \quad n = 0, 1, 2, 3, \dots$$

The set of frequencies represented by the above relation are the *normal modes* of oscillation of such a system. The lowest frequency given by  $v/4L$  is the fundamental mode or the first harmonic.

16. A string of length  $L$  fixed at both ends or an air column closed at one end and open at the other end or open at both the ends, vibrates with certain frequencies called their normal modes. Each of these frequencies is a *resonant frequency* of the system.
17. *Beats* arise when two waves having slightly different frequencies,  $v_1$  and  $v_2$  and comparable amplitudes, are superposed. The beat frequency is

$$v_{\text{beat}} = v_1 \sim v_2$$

Physical quantity	Symbol	Dimensions	Unit	Remarks
Wavelength	$\lambda$	[L]	m	Distance between two consecutive points with the same phase.
Propagation constant	$k$	[L <sup>-1</sup> ]	m <sup>-1</sup>	$k = \frac{2\pi}{\lambda}$
Wave speed	$v$	[LT <sup>-1</sup> ]	m s <sup>-1</sup>	$v = v\lambda$
Beat frequency	$v_{beat}$	[T <sup>-1</sup> ]	s <sup>-1</sup>	Difference of two close frequencies of superposing waves.

### POINTS TO PONDER

1. A wave is not motion of matter as a whole in a medium. A wind is different from the sound wave in air. The former involves motion of air from one place to the other. The latter involves compressions and rarefactions of layers of air.
2. In a wave, energy and *not the matter* is transferred from one point to the other.
3. In a mechanical wave, energy transfer takes place because of the coupling through elastic forces between neighbouring oscillating parts of the medium.
4. Transverse waves can propagate only in medium with shear modulus of elasticity, Longitudinal waves need bulk modulus of elasticity and are therefore, possible in all media, solids, liquids and gases.
5. In a harmonic progressive wave of a given frequency, all particles have the same amplitude but different phases at a given instant of time. In a stationary wave, all particles between two nodes have the same phase at a given instant but have different amplitudes.
6. Relative to an observer at rest in a medium the speed of a mechanical wave in that medium ( $v$ ) depends only on elastic and other properties (such as mass density) of the medium. It does not depend on the velocity of the source.

### EXERCISES

- 14.1** A string of mass 2.50 kg is under a tension of 200 N. The length of the stretched string is 20.0 m. If the transverse jerk is struck at one end of the string, how long does the disturbance take to reach the other end?
- 14.2** A stone dropped from the top of a tower of height 300 m splashes into the water of a pond near the base of the tower. When is the splash heard at the top given that the speed of sound in air is 340 m s<sup>-1</sup>? ( $g = 9.8 \text{ m s}^{-2}$ )
- 14.3** A steel wire has a length of 12.0 m and a mass of 2.10 kg. What should be the tension in the wire so that speed of a transverse wave on the wire equals the speed of sound in dry air at 20°C = 343 m s<sup>-1</sup>.
- 14.4** Use the formula  $v = \sqrt{\frac{\gamma P}{\rho}}$  to explain why the speed of sound in air
- (a) is independent of pressure,
  - (b) increases with temperature,
  - (c) increases with humidity.

**14.5** You have learnt that a travelling wave in one dimension is represented by a function  $y = f(x, t)$  where  $x$  and  $t$  must appear in the combination  $x - vt$  or  $x + vt$ , i.e.  $y = f(x \pm vt)$ . Is the converse true? Examine if the following functions for  $y$  can possibly represent a travelling wave :

- (a)  $(x - vt)^2$
- (b)  $\log [(x + vt)/x_0]$
- (c)  $1/(x + vt)$

**14.6** A bat emits ultrasonic sound of frequency 1000 kHz in air. If the sound meets a water surface, what is the wavelength of (a) the reflected sound, (b) the transmitted sound? Speed of sound in air is  $340 \text{ m s}^{-1}$  and in water  $1486 \text{ m s}^{-1}$ .

**14.7** A hospital uses an ultrasonic scanner to locate tumours in a tissue. What is the wavelength of sound in the tissue in which the speed of sound is  $1.7 \text{ km s}^{-1}$ ? The operating frequency of the scanner is 4.2 MHz.

**14.8** A transverse harmonic wave on a string is described by

$$y(x, t) = 3.0 \sin (36 t + 0.018 x + \pi/4)$$

where  $x$  and  $y$  are in cm and  $t$  in s. The positive direction of  $x$  is from left to right.

(a) Is this a travelling wave or a stationary wave ?

If it is travelling, what are the speed and direction of its propagation ?

- (b) What are its amplitude and frequency ?
- (c) What is the initial phase at the origin ?
- (d) What is the least distance between two successive crests in the wave ?

**14.9** For the wave described in Exercise 14.8, plot the displacement ( $y$ ) versus ( $t$ ) graphs for  $x = 0, 2$  and  $4$  cm. What are the shapes of these graphs? In which aspects does the oscillatory motion in travelling wave differ from one point to another: amplitude, frequency or phase ?

**14.10** For the travelling harmonic wave

$$y(x, t) = 2.0 \cos 2\pi (10t - 0.0080 x + 0.35)$$

where  $x$  and  $y$  are in cm and  $t$  in s. Calculate the phase difference between oscillatory motion of two points separated by a distance of

- (a) 4 m,
- (b) 0.5 m,
- (c)  $\lambda/2$ ,
- (d)  $3\lambda/4$

**14.11** The transverse displacement of a string (clamped at its both ends) is given by

$$y(x, t) = 0.06 \sin \left( \frac{2\pi}{3} x \right) \cos (120 \pi t)$$

where  $x$  and  $y$  are in m and  $t$  in s. The length of the string is 1.5 m and its mass is  $3.0 \times 10^{-2} \text{ kg}$ .

Answer the following :

- (a) Does the function represent a travelling wave or a stationary wave?
- (b) Interpret the wave as a superposition of two waves travelling in opposite directions. What is the wavelength, frequency, and speed of each wave ?

- (c) Determine the tension in the string.
- 14.12** (i) For the wave on a string described in Exercise 15.11, do all the points on the string oscillate with the same (a) frequency, (b) phase, (c) amplitude? Explain your answers. (ii) What is the amplitude of a point 0.375 m away from one end?
- 14.13** Given below are some functions of  $x$  and  $t$  to represent the displacement (transverse or longitudinal) of an elastic wave. State which of these represent (i) a travelling wave, (ii) a stationary wave or (iii) none at all:
- (a)  $y = 2 \cos (3x) \sin (10t)$
- (b)  $y = 2\sqrt{x - vt}$
- (c)  $y = 3 \sin (5x - 0.5t) + 4 \cos (5x - 0.5t)$
- (d)  $y = \cos x \sin t + \cos 2x \sin 2t$
- 14.14** A wire stretched between two rigid supports vibrates in its fundamental mode with a frequency of 45 Hz. The mass of the wire is  $3.5 \times 10^{-2}$  kg and its linear mass density is  $4.0 \times 10^{-2}$  kg m<sup>-1</sup>. What is (a) the speed of a transverse wave on the string, and (b) the tension in the string?
- 14.15** A metre-long tube open at one end, with a movable piston at the other end, shows resonance with a fixed frequency source (a tuning fork of frequency 340 Hz) when the tube length is 25.5 cm or 79.3 cm. Estimate the speed of sound in air at the temperature of the experiment. The edge effects may be neglected.
- 14.16** A steel rod 100 cm long is clamped at its middle. The fundamental frequency of longitudinal vibrations of the rod are given to be 2.53 kHz. What is the speed of sound in steel?
- 14.17** A pipe 20 cm long is closed at one end. Which harmonic mode of the pipe is resonantly excited by a 430 Hz source? Will the same source be in resonance with the pipe if both ends are open? (speed of sound in air is 340 m s<sup>-1</sup>).
- 14.18** Two sitar strings A and B playing the note 'Ga' are slightly out of tune and produce beats of frequency 6 Hz. The tension in the string A is slightly reduced and the beat frequency is found to reduce to 3 Hz. If the original frequency of A is 324 Hz, what is the frequency of B?
- 14.19** Explain why (or how):
- (a) in a sound wave, a displacement node is a pressure antinode and vice versa,
- (b) bats can ascertain distances, directions, nature, and sizes of the obstacles without any "eyes",
- (c) a violin note and sitar note may have the same frequency, yet we can distinguish between the two notes,
- (d) solids can support both longitudinal and transverse waves, but only longitudinal waves can propagate in gases, and
- (e) the shape of a pulse gets distorted during propagation in a dispersive medium.